



HEATER MOUNTING KIT: 1CCCAHMK (Fits, Club Car Carryall 4x2 Carryall 300, 500, 550 & 700)

Must be installed with Curtis Cab: 1CCCA-1 or 47587415001
 Must be installed with Curtis Electric Heater 9PH20S70
 Must be installed with Curtis Alternator Kit 1ACCA14DRK
 May be installed along with Curtis Air Conditioner 1ACUNIT-G2

Approximate Installation Time *

Experienced Dealer Technician – 1 Hour
--

Average Dealer Technician – 2 Hours

Do-It-Yourself – 3 Hours

(* = Not including accessories)

The contents of this envelope are the property of the owner. Leave with the owner when installation is complete.

Rev. A, 8/20/2018

P/N: IM-1CCCAHMK

WARNINGS, TIPS, & REQUIRED TOOLS

For accurate installation, proper operation, and years of satisfaction, please read and understand the installation and owner's manual fully prior to installing the accessory.

From all of us at Curtis, we thank you for choosing our product.

California Health and Safety Proposition 65 Warning: This product may contain chemicals known to the state of California to cause cancer and birth defects or other reproductive harm.

GENERAL INFORMATION BEFORE YOU START

HELPFUL HINTS:

- Refer to parts diagram found in the service parts section of this manual to help identify parts during the assembly process.
- To assist with the installation, leave all fasteners loose for later adjustment unless otherwise specified.
- Read and understand all instructions before beginning.

TOOLS REQUIRED:

- Set of Standard and Metric Sockets (3/8" Drive)
- 3/8" Drive Ratchet
- Set of Standard and Metric Open-End Wrenches
- #2 and #3 Phillips Head Screwdrivers
- Snips
- Tool to trim plastic (reamer, dremel, etc.)

KIT INSTALLATION

STEP 1: (VEHICLE PREP)

- 1.1** This heater kit can be installed with or without the rooftop A/C.

If installing the **heater with a rooftop A/C**, begin by installing the roof kit first, followed by the alternator kit before this heater kit is installed.
 Note: when installing the A/C unit into the roof, there is an additional harness in this kit that must be run at the same time as the main A/C power harness. Please read forward to identify this wire and install it before securing roof unit.

If installing the **heater without an A/C**, begin by installing the heater kit first before installing the alternator kit.

- 1.2** Raise and secure the cargo box on the rear of the vehicle. Fig. 1.2.
 OPTIONAL: Remove the cargo box from the vehicle for better access to the engine.

Tools

9/16" wrench and socket

- 1.3** Remove the seat from the vehicle. Fig. 1.3

OPTIONAL: remove the cab doors for better access inside the cab.

- 1.4** Disconnect both wires from the battery, negative then positive. Fig 1.4.

Tools

9/16" wrench or socket

- 1.5** Remove vehicle hood. Figure 1.5.



Fig. 1.2 (Bed Removed)



Fig. 1.3 (Seat Removal)



Fig. 1.4 (Disconnect Battery)



Fig. 1.5 (Hood Removal)

KIT INSTALLATION

STEP 2: (Heater Installation)

- 2.1** Remove and save the bolts from windshield latch. Figure 2.1.

Tools

1/2" wrench and socket



Fig. 2.1 (Remove Latch Bolts)

- 2.2** Install the driver's side heater bracket per Figure 2.2. Note: the driver's side bracket includes a rectangular cutout for the switch

Hardware Used

5/16-18, 1" flanged hex screw
5/16-18 flanged hex nut

Qty

2
2

Tools

1/2" wrench and socket

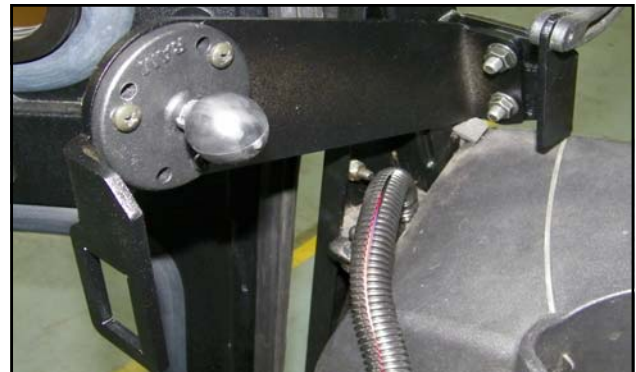

Fig. 2.2 (Install Driver Side Bracket)

- 2.3** Install the passenger side heater bracket per Figure 2.3.

Hardware Used

5/16-18, 1" flanged hex screw
5/16-18 flanged hex nut

Qty

2
2

Tools

1/2" wrench and socket



Fig. 2.3 (Install Passenger Side Bracket)

- 2.4** Install thumbscrew clamp and Heater (from Curtis kit 9PH20S70) onto the driver's side bracket oriented roughly as shown and tighten thumbscrew. Fig. 2.4.

- 2.5** Repeat for the passenger side.



Fig. 2.4 (Install Heater and Clamp to Bracket)

KIT INSTALLATION

STEP 3: (WIRING)

- 3.1** Locate the relay/switch wire harness (9SV-WH-00087). Route the plug that mates to the rear of the rocker switch through the rectangular cutout in the driver's side bracket and connect to the switch. Fig. 3.1.

Snap the switch into the bracket.



Fig. 3.1 (Switch Connections)

- 3.2** The rear of the switch has two sets of wires (red/black and pink/green) coming off the back of it. Disconnect the relay holders from the red/black wires at the bullet terminals and route the two sets of wires (red/black and pink/green) downwards and through the hole under the dash so that the wires are routed out under the hood. Use a dremel or reamer to trim some plastic if necessary to ease installation. Fig. 3.2.

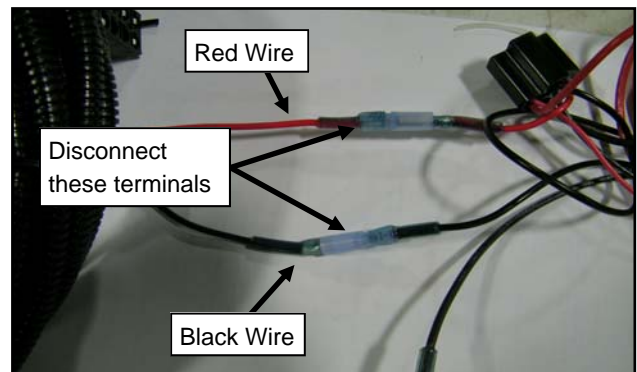

Fig. 3.2 (Terminals to Disconnect)

- 3.3** Feed the wires from the driver's side heater down through the same hole. Fig. 3.3.
- 3.4** Feed the wires from the passenger's side heater downwards and out under the hood. Use a dremel or reamer to trim some plastic if necessary to ease installation.

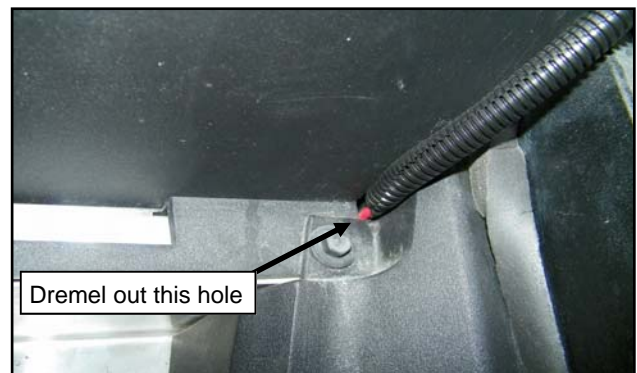

Fig. 3.3 (Hole for Wire Routing)

- 3.5** Route the wires from the passenger side heater along the vehicle frame to the driver's side. Figure 3.5



Fig. 3.5 (Routing of Wire Harness)

KIT INSTALLATION

STEP 3: (WIRING CONTINUED)

- 3.6** Route the two heater harness wires and the red/black harness from the switch to the engine compartment.

If installing the heater with an A/C, route the pink/green wire to the engine compartment as well.

If no A/C will be installed, leave the pink/green wires under the hood.

- 3.7** In the engine compartment, reconnect the bullet terminals on the red/black harness that were disconnected in step 3.2 with the corresponding wires on the relay holders. Fig. 3.7.

Use the Wiring Diagram on page 14 or 15 (depending on your configuration) to make the following connections:

- 3.8** Connect the yellow push-on terminals on red wires from the heater units to the mating terminal extending out of relay socket 3.
- 3.9** Install the relays supplied with the heater mounting kit into their corresponding sockets.

Install the relay with the larger terminals (9SV-85-12-0038) into the large relay socket (Figure 3.9a) (labeled socket 3 on the wire diagram)

Install the Beuler Time delay relay (8SV-114-00021) into the remaining relay socket (Figure 3.9b) (labeled socket 4 on the wire diagram)

Note: There are 2 push-on terminals (red and black) that remain unused, these are for the installation of other options.

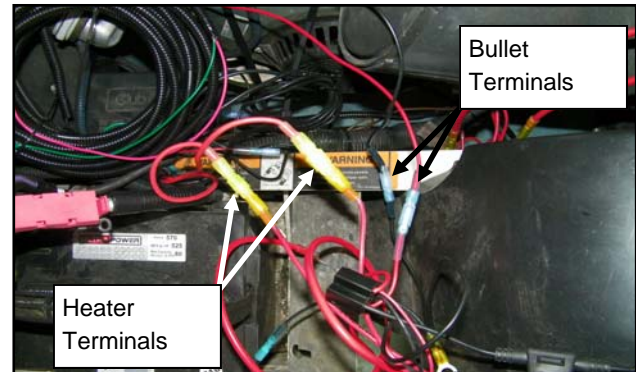

Fig. 3.7 (Connect Heaters & Relay Harness)

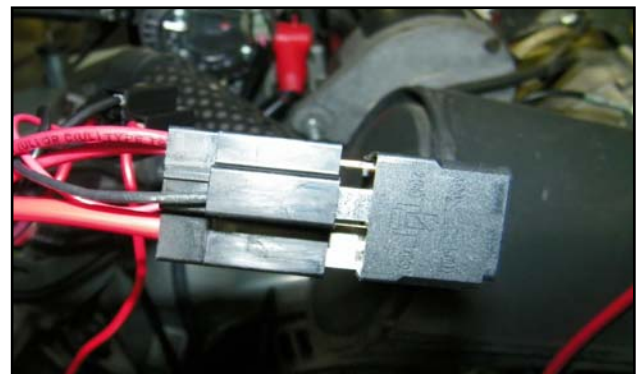

Fig. 3.9a (Install Larger Relay)



Fig. 3.9b (Install Smaller Relay)

KIT INSTALLATION

STEP 4: (WIRING HEATER ONLY)

If installing the heater kit with an A/C, skip step 4 and proceed to Step 5 on page 11.

The following steps use components from the alternator kit.

- 4.1 Zip tie the controller (located in the alternator kit) to the frame under the hood of vehicle shown in figure 4.1
- 4.2 Zip tie alternator relay harness 9SV-WH-00074 (located in the alternator kit) to same area of the vehicle frame under the hood. Shown in figure 4.2.
- 4.3 Install a standard relay (9SV-85-01-0022) (located in the heater mounting kit) into relay socket 5 located on the controller harness as shown on page 14.
- 4.4 Install a second standard relay (9SV-85-01-0022) (located in the heater mounting kit) into the relay socket 1 on the alternator relay harness as shown on page 14.
- 4.5 Install time delay solid state relay (0-10 sec) on-delay (8SV-114-00023) (located in the alternator kit) into socket 2 of relay harness (located in the alternator kit). Note that the solid state relay can only fit into socket 2, due to its shape. Fig. 4.5.

NOTE: Verify that all of the relays are in the correct positions.

CAUTION: Never replace any timed relay in this device with a standard automotive relay.

Note: Relay 8SV-114-00022 supplied in the alternator kit will not be used when installing the heaters without A/C.



Fig. 4.1 (Install Controller)



Fig. 4.2 (Install Alternator Relay Harness)

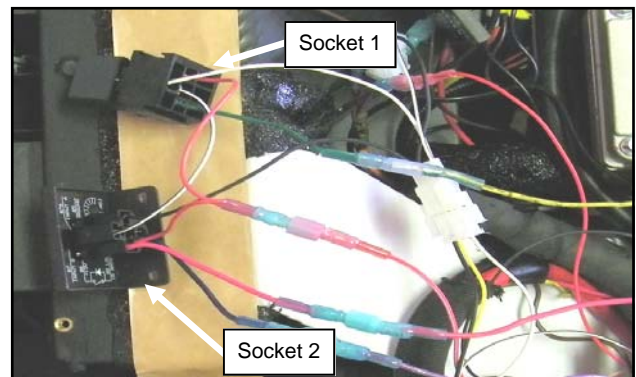
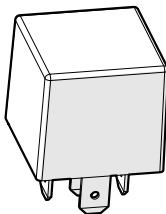
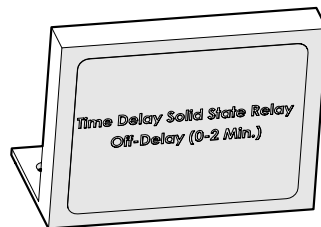

Fig. 4.5 (Connect Terminals to Fuse)



9SV-85-01-0022
Std. Automotive Relay
Removed from A/C Unit



8SV-114-00022
Time Delay Relay Off (0-2 Min.)
Set for 2 Minutes

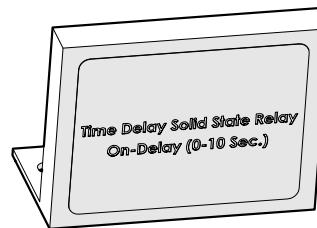

8SV-114-00023
Time Delay Relay On (0-10 Sec.)
Set for 5 Seconds

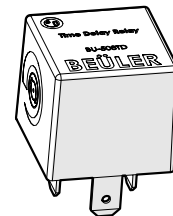

8SV-114-00021
Time Delay Relay
Set for 60 Seconds

KIT INSTALLATION

STEP 4: (WIRING HEATER ONLY)

- 4.6** Under the hood, locate the ring terminal that is on the black wire with the white controller plug on it that is at the end of the controller wire harness. Connect the ring terminal to the vehicle frame bolt.

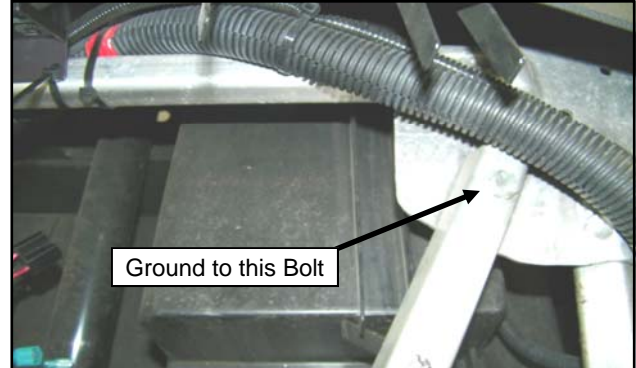

Fig. 4.6 (Ground Wire under Hood)

- 4.7** Connect the relay wire harness 9SV-WH-00074 and controller wires under the hood as follows:

Relay Harness Terminal	Destination
Male Plug (White)	Female white plug of Controller Harness (9SV-WH-00089)
Female Plug (White)	Male white plug of Controller
Red Wires	Red wires of Controller (yellow terminal)
Pink Wire	Pink wire of Controller Harness (9SV-WH-00089)
Purple Wire	Purple wire of Controller Harness (9SV-WH-00089)
Green Wire	Unused
Black Wire	Unused

Controller Wire	Destination
Green Wire (from relay socket)	Green Wire from Heater Switch
Gray Wire (with diode holder)	Brown wire of Controller Harness (9SV-WH-00089)

KIT INSTALLATION

STEP 4: (WIRING HEATER ONLY)

- 4.8** Remove the cover from the vehicle solenoid, located next to the battery. Connect the purple wire on the controller harness to the vehicle solenoid. To help identify this wire, it has a 5-amp fuse near the ring terminal, and has a section of black wire at the fuse holder. Figure 4.8 (shown with cover off).

The ring terminal must be attached to the large lug on the starter side of the solenoid (not the battery side). *If this ring terminal is on the wrong side of the solenoid, the controller will not turn off with the engine.*

Install the cover back over the vehicle solenoid, ensuring no wires are pinched by the cover.

Tools

5/16" wrench or socket
13mm wrench or socket

- 4.9** Locate the RPM signal wire harness (9SV-WH-00081) (located in the alternator kit). The harness is a 2-foot long wire with a male bullet and female push-on terminals.

Locate the connector for the RPM signal, underneath the rear of the engine. This is a double female bullet connector covered by a clear rubber boot. Figure 4.9.

Install the male bullet terminal from the RPM signal wire into the unused side of the connector. Route the wire up the left side of the engine toward the battery.

- 4.10** Connect the female push-on terminal from the RPM signal wire harness to the male terminal on the brown wire from the controller wire harness. Figure 4.10.

- 4.11** Route the white plug of the controller harness under the exhaust tube and connect into the receptacle of the alternator once it is installed. Only the top terminal of the "T" on the plug is used. Figure 4.11.



Fig. 4.8 (Solenoid Connection)

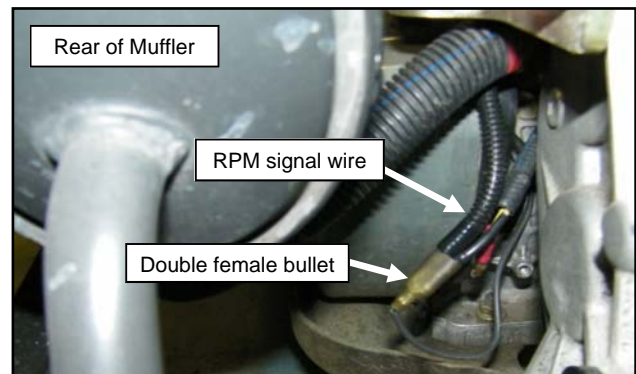

Fig. 4.9 (Locate RPM signal connector)

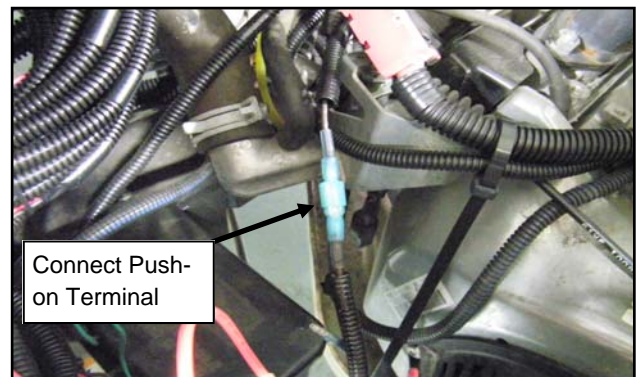

Fig. 4.10 (Connect to RPM Signal Wire)

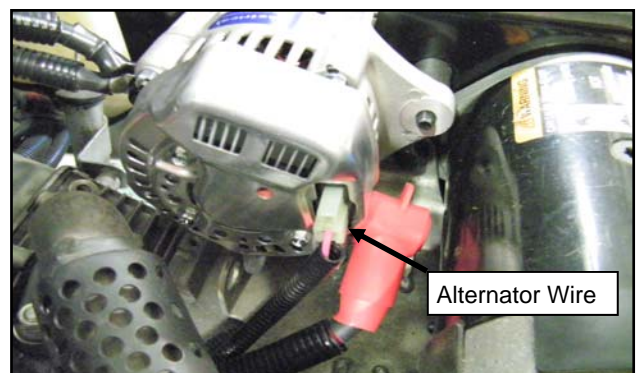

Fig. 4.11 (Connect to Alternator)

KIT INSTALLATION

STEP 4: (WIRING HEATER ONLY)

- 4.12** Locate the main power harness in the alternator kit. Remove the nut at the fuse that is securing the red wire from the long portion of the harness with the wire covering on it. This will split the harness into two pieces. As shown on page 14.

The long section of harness with the wire covering on it will not be used when installing heaters without A/C.

- 4.13** Install the two small ring terminals on the heater wire harness to the fuse holder stud as shown in the wire diagram and re-install the nut.

- 4.14** Install the alternator kit at this time. When installing, skip over any steps that have already been completed as part of this heater installation.

Be sure to connect the pink wire from the controller harness to the alternator.

When reconnecting the battery, ensure that the two ring terminals on the harnesses from the heaters are connected to ground as well as the ring terminal on the heater relay harness 9SV-WH-00087. Fig. 4.14.

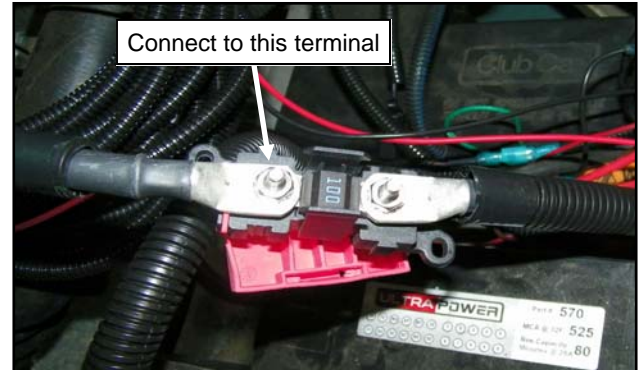

Fig. 4.12 (Connect to Alternator Harness Fuse)

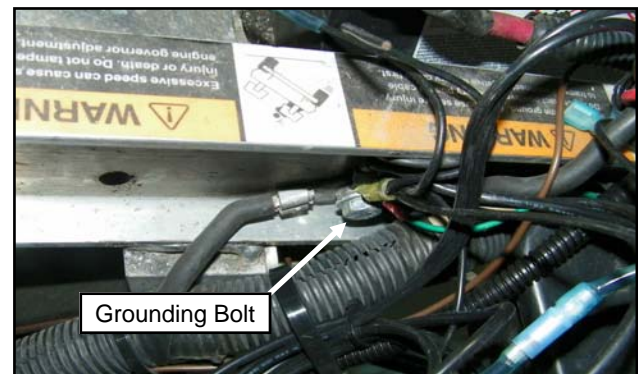

Fig. 4.14 (Install Ground Terminals)

KIT INSTALLATION

STEP 5: (WIRING WITH A/C UNIT)

Note: Refer to the wire diagram on the last page for clarity

Note: The controller harness 9SV-WH-00089 is not used with the A/C and can be discarded.

- 5.1 Route the Green/pink set of wires up to the A/C unit along side the main power wires
- 5.2 Disconnect the green wire on the controller relay from the pink wire on the A/C unit that is connected to the trigger on the main solenoid. Fig. 5.2.

Connect the green wire on the heater harness to the green wire coming from the controller relay.

Connect the pink wire on the heater harness to the pink wire on the A/C unit that is connected to the trigger on the main solenoid.

- 5.3 In the engine compartment, connect the two small ring terminals on heater harness to the 100 Amp Fuse Terminal on the main power wire running from the alternator to the battery. This connection should be on one of the posts on the middle portion of wire so that it is fused from both the alternator and battery as shown on page 15 and Figure 5.3.

- 5.4 Connect 2 heater ring terminals and ground ring terminal on relay harness to ground bolt on frame of vehicle. Fig. 5.4.
- 5.5 Continue with wire connections as shown in the alternator kit installation manual.
- 5.6 Be sure to secure all wires to vehicle frame and away from moving parts.

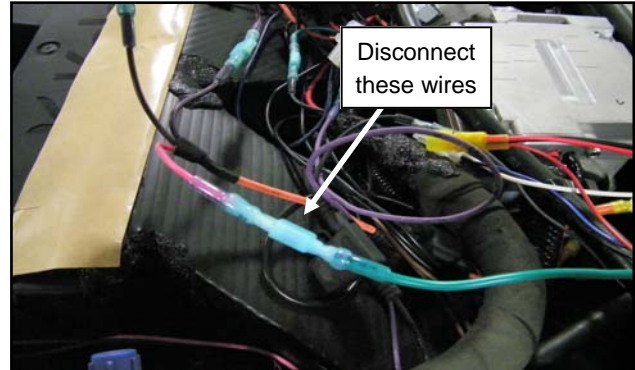

Fig. 5.2 (Disconnect Green/Pink Wire in A/C)

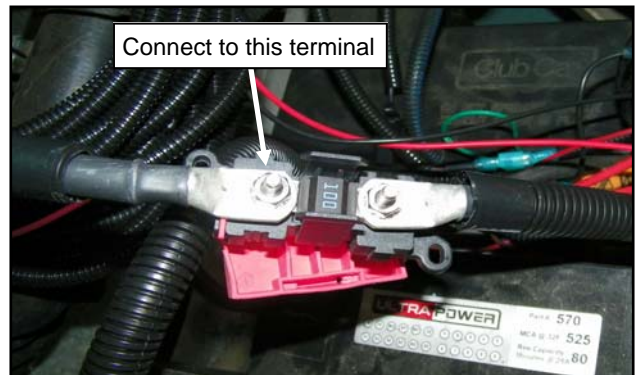

Fig. 5.3 (Connect to Alternator Harness Fuse)

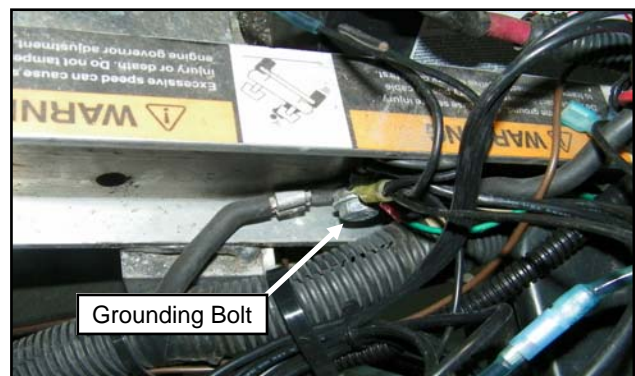

Fig. 5.4 (Install Ground Terminals)

KIT INSTALLATION

STEP 6: (FINISHING TOUCHES)

- 6.1** Inspect all fasteners, they should be fully tightened before starting vehicle.
- 6.2** Inspect all wires to make sure they are sufficiently tied down and away from hot or moving parts.
- 6.3** Start the vehicle in neutral, turn the switch to heat, and turn on the heater. Run the engine at a high RPM. The red light on the switch should turn on and warm air should begin to flow after 30 to 60 seconds. Verify that the heater is functioning. Repeat for the A/C if installed.

CLUB CAR CARRYALL 4X2 HEATER MOUNTING KIT SERVICE PARTS

BALL & SOCKET MOUNT, 2.5" ROUND BASE,
1" BALL; P/N: 9SV-9BSM-02

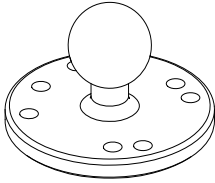

SOCKET EXT, 3" SOCKET TO SOCKET, 1"
BALL; P/N: 9SV-9BSM-03

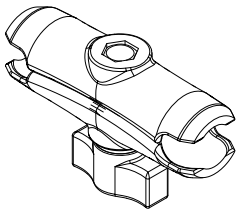

ROCKER SWITCH W/ COVER, 3 POS. FOR
HEATER & A/C; P/N: 9SV-OHC-29

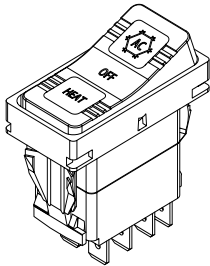

RELAY, 12V DC, 30 AMP, 60 SEC TIME DELAY
P/N: 8SV-114-00021

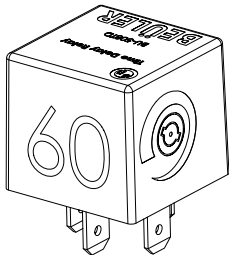

MAXI RELAY, 12V, 50A
CONTINUOUS
P/N: 9SV-85-12-0038

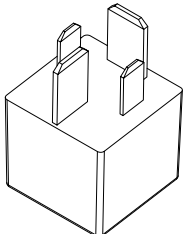

STANDARD RELAY, 12V
P/N: 9SV-85-01-0022

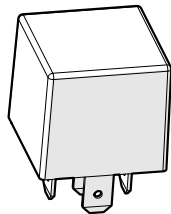

RELAY HARNESS, ELECTRIC HEATER
P/N: 9SV-WH-00087

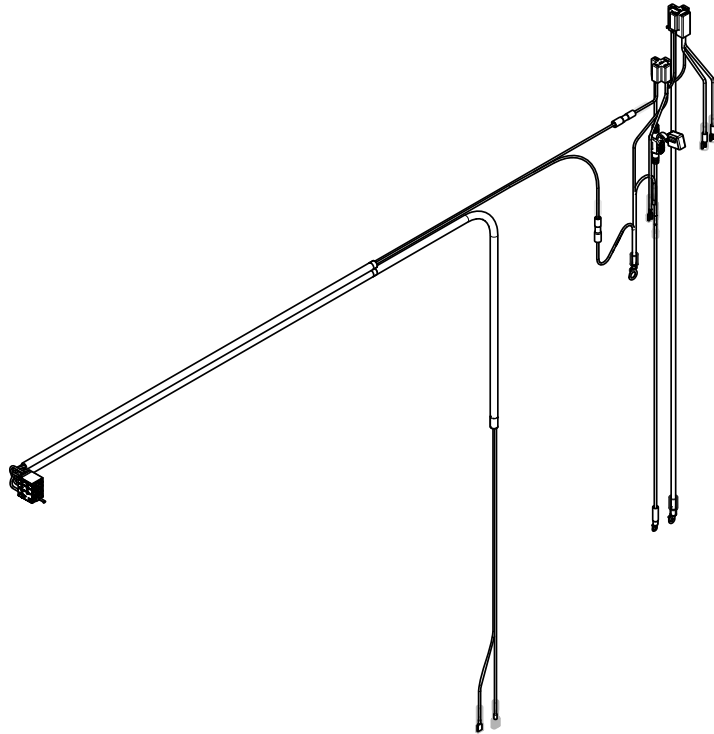

CONTROLLER HARNESS, ELECTRIC HEATER
P/N: 9SV-WH-00089

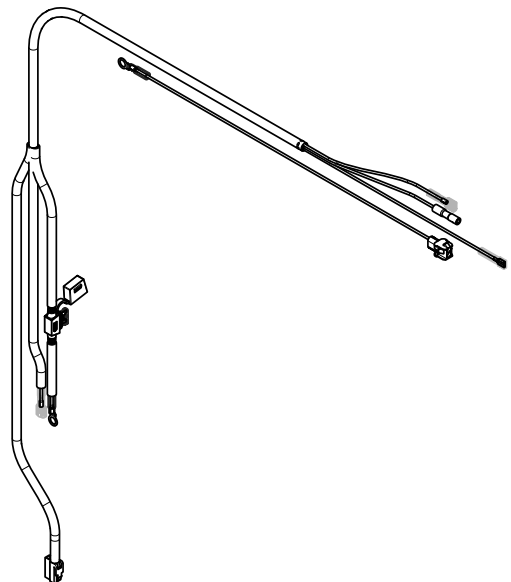

A/C + Heat Wiring

Wires marked ** are part of main power harness 9SV-WH-00065

Wires marked + are part of heater relay harness 9SV-WH-00087

Wires marked # are part of alternator kit relay harness 9SV-WH-00074

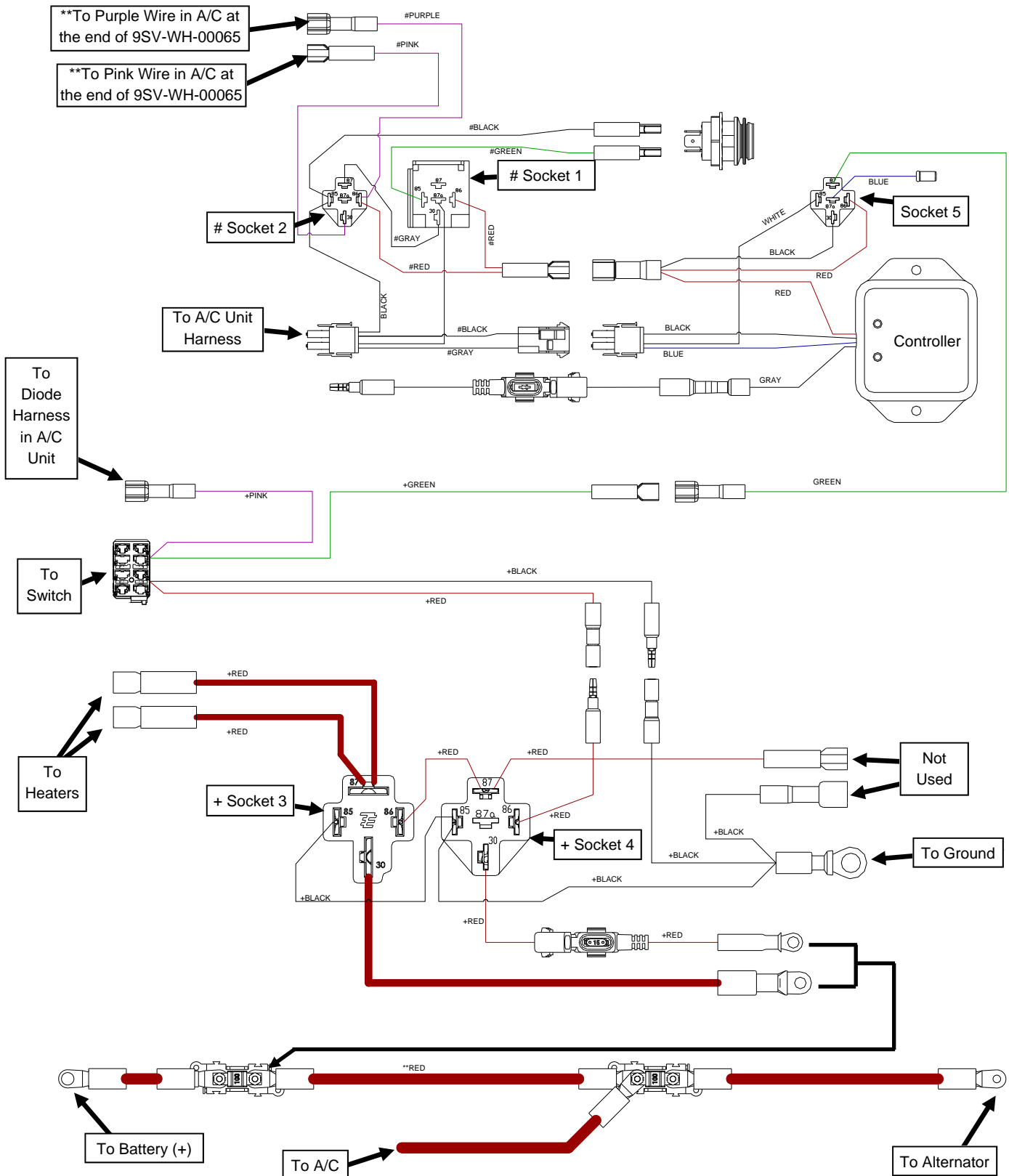

This wire is a portion of the main power harness (9SV-WH-00065) in the alternator kit.