



Curtis Fast-Cast 600
Fine Material Spreader
1/4 cubic yard with
spinner speed control
p/n: 1CS11



Available Options:

1. Fast-Cast 600 Hopper Vibrator (p/n: 1CS11HV)
2. Fast-Cast 600 Hopper Extension (p/n: 1CS11SC)

Approximate Installation Time *

Experienced Dealer Technician – 1 1/2 Hours

Average Dealer Technician – 2 1/2 Hours

Do-It-Yourself – 3 1/2 Hours

(*=Not including accessories)

The contents of this envelope are the property of the owner. Leave with the owner when installation is complete.

Rev. B, 08/05/2019

p/n: IM-1CS11

TABLE OF CONTENTS

WARNINGS AND TIPS 3
PARTS BREAKDOWN..... 4-5
SPREADER INSTALLATION 6-8
WIRING SCHEMATIC..... 9
FEATURES & OPERATION..... 10
CARE AND MAINTENANCE 10
PARTS LIST 11-12

IMPORTANT: Before you Start...

- ▶ Do not attempt to operate this Spreader until you have read and understand all warnings and instructions in the Owner’s manual and on Spreader unit.
- ▶ For your safety, warning and information decals have been affixed to this product to remind all operators of safety precautions. If decals are marked, damaged, or destroyed, replace with new decals ordered from Curtis Industries, LLC.
- ▶ Failure to maintain components can void warranty.
- ▶ Read installation instructions all the way through before beginning installation.



Most accidents are preventable and caused by human error. Exercise care and precautions to prevent the possibility of injury to operator or to others. *Failure to read and follow all warnings and instructions may lead to serious injuries or death.*

1. Never run spreader without all guards in place.
2. Never allow children to operate or climb on equipment.
3. Do not stand behind or next to material chute while spreader is discharging.
4. Before working with the spreader, secure all loose fitting clothing and unrestrained hair.
5. Always keep hands, feet, and clothing away from power-driven parts. Always check areas to be spread to be sure no hazardous conditions or substances are in the area.
6. Always make sure personnel are clear of areas of danger when using equipment.
7. Do not overfill Spreader.
8. Never operate equipment when under the influence of alcohol, drugs, or medication that might alter your judgment and/or reaction time.
9. Never attempt to adjust or service spreader while it is running.
10. Never attempt to un-jam auger while spreader is running.
11. Always inspect unit for defects: broken, worn, or bent parts, weakened areas on spreader or mount.
12. Always shut off vehicle and power source before attempting to attach or detach or service spreader unit. Be sure vehicle/power source is properly braked or chocked.
13. Remember, it is the owner’s responsibility to communicate information on safe usage and proper maintenance of all equipment.

California Health and Safety Proposition 65 Warning: This product may contain chemicals known to the state of California to cause cancer and birth defects or other reproductive harm.

Complete this check list prior to initial start up and Operation	
	Read and understand Curtis installation and owner’s manual
	Read and understand all WARNING decals.
	Grease all lubrication points
	Wire Control Panel
	Coat harness connectors with dielectric grease
	Verify Spreader is secure in vehicle using provided ratchet straps.

Parts in Speed Control kit

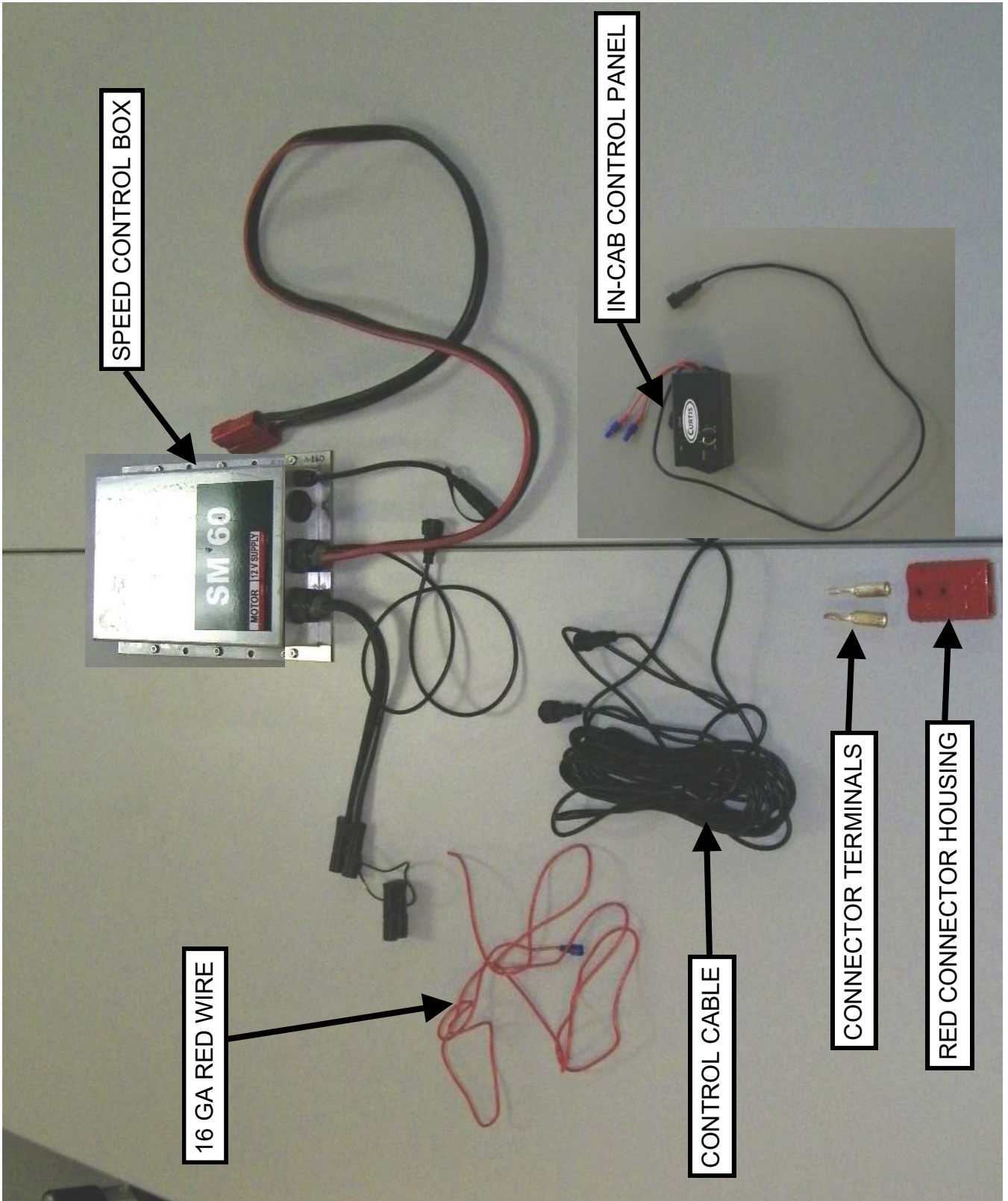

Parts in Spreader Kit

(* in 3 of the text boxes indicates parts that are not used with speed control)

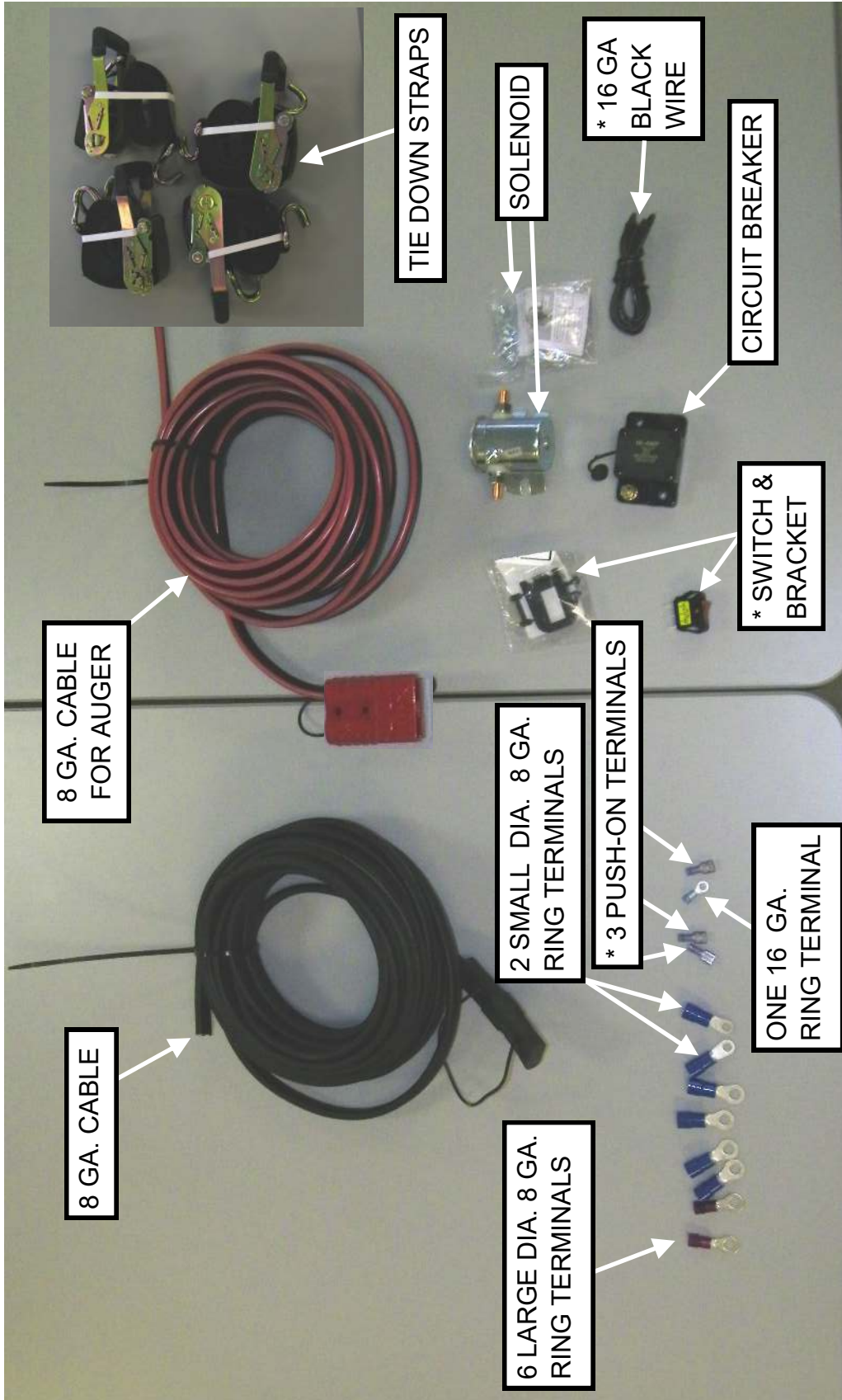

INSTALLATION

Section 1 Install Spreader.

1A. The Fast-Cast 600 Spreader is designed for mounting in the bed of most Utility vehicles. Four hold-down straps are provided for securing the Spreader to the Vehicle.

1B . See fig. 1B. Remove the Tailgate completely from the vehicle if possible. Using an appropriate lift and an assistant, place the empty spreader in the vehicle with approximately 16" hanging off the back of the bed. **HINT: Installing 2 x4 lumber or similar on the bottom of the spreader helps protect the vehicle bed from scratching and also helps the spreader to slide around less while in use.** Remove the two hairpin clips. Hold the chute and remove the 2 pins and swing the chute into the down position. Reinstall the pins and clips. Center the Spreader in the bed of the UTV and shift the Spreader as far forward as possible.



Fig. 1B



Fig. 1C

1C. See fig. 1C. Use two of the hold-down straps to secure the front of the spreader to the frame of the vehicle.

To prevent accidental dumping with the spreader installed, utility vehicles with dump beds must have the straps attach to the vehicle frame or a secondary safety chain or strap must be installed to prevent serious injury or death by accidental dumping.



WARNING

vehicles with dump beds must have the straps

attach to the vehicle frame or a secondary safety chain or strap must be installed to prevent serious injury or death by accidental dumping.

1D. See fig. 1D. Use the remaining two hold-down straps to secure the back of the spreader to the frame of the vehicle.



Fig. 1D

WIRING

Section 2 Wiring (refer to schematic on page 9)

- 2A. Determine an appropriate location for the in-cab control panel and mount to the vehicle. **Note: due to the number of different vehicles and mounting locations, hardware is not provided.** Use one of the female spade connectors provided to connect the 16 ga. red wire provided to one of the terminals on the control panel. Route the other to a 15 amp power source, cut to length and connect. **Note: The connector is not provided.**
- 2B. Disconnect the negative battery terminal.
- 2C. Find a suitable place to mount the supplied solenoid near the battery and mount to vehicle. **Again, due to the number of different vehicles and mounting locations, hardware is not provided.**
- 2D. Locate a suitable place to mount the circuit breaker between the battery and the solenoid. **Again, due to the number of different vehicles and mounting locations, hardware is not provided.**
- 2E. Attach the supplied 25 foot cable with the matching connector to the auger motor and to the solenoid installed in step 2C. Cut to length such that the wire labeled positive (or red) can be connected to one of the larger solenoid studs and the other wire can be connected to the negative battery terminal. Crimp the larger diameter 8 ga. ring terminals to the ends of the wires, which will be installed in a later step.
- 2F. Cut suitable lengths of wire from the remaining 25 foot cable provided to reach from the positive battery terminal to the circuit breaker and then another from the circuit breaker to the large post on the solenoid **NOT** selected in step 2E. Crimp the appropriate size ring terminals onto the wire to connect the battery (large diameter) to the circuit breaker (small diameter) and the circuit breaker to the solenoid (large diameter).
- 2G. The speed control box can be mounted anywhere between the battery and the spinner motor that the cable between the control box and spinner motor will allow, usually in the bed. **Once again hardware is not provided for the reasons stated above.** Some things to consider.
- Make sure there is enough slack in the cable to allow the spinner motor to be flipped up.
 - Do not mount to the outside of the spreader if installing an optional vibrator kit.
 - If you do mount to the spreader, you will need to disconnect the control cable and the 12-volt supply cable when removing the spreader but the control box is out of the way when the spreader is removed.
 - You only need to disconnect the wire going to the spinner motor when you mount the speed control box separate from the spreader.
 - It is NOT recommended to mount with the cables coming straight up out of the box.

WIRING

Section 2 Wiring (refer to schematic on page 9)

- 2H. Using some of the remaining cable from step 2F, crimp the supplied connectors for the loose red connector housing to the two 8 ga. wires and insert into the appropriate positive and negative sides of the connector housing. Plug into the 12-volt supply connector on the control box. Route to the battery area and trim the positive cable to length to attach to the unused large stud on the solenoid and the negative battery terminal. Crimp the 2 remaining large 8 ga. ring terminals onto the wires .
- 2I. Attach the two positive wires from steps 2E and 2H to the open large stud on the solenoid. Attach the negative wires from both steps to the negative battery terminal.
- 2J. Crimp a second female push-on terminal to the remaining 16 ga. wire and connect to the remaining red wire on the in-cab control panel. Route the other end to to the solenoid, cut to length and install to the small stud with the 16 ga. ring terminal provided.
- 2K. Connect the control cable between the in-cab control panel and the speed control box. Reconnect the negative battery terminal. Test spreader function and secure all cables and wires with wire ties.
- 2L. Re-connect the negative battery terminal and check operation of the spreader.

SCHEMATIC

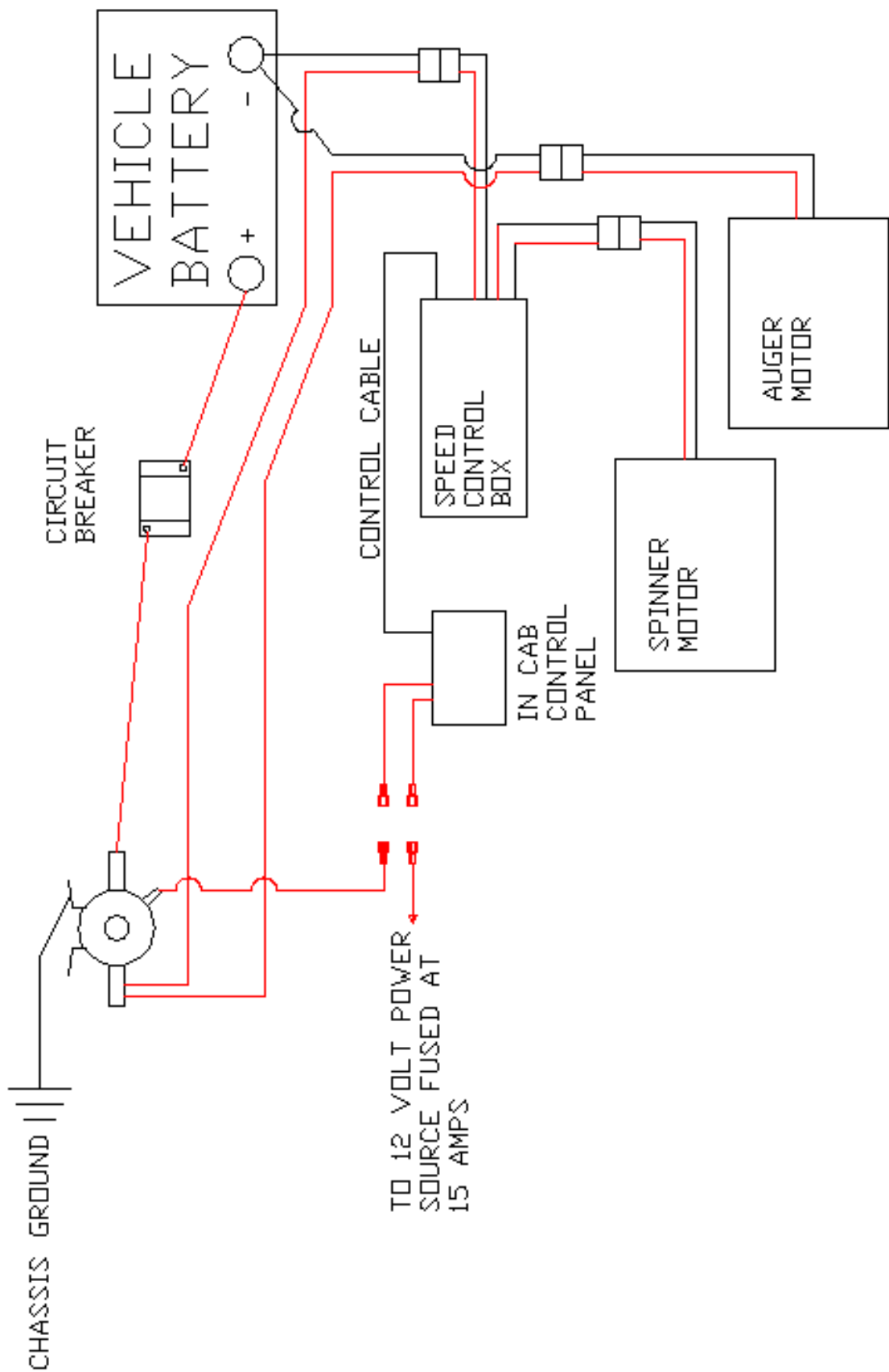

FEATURES & OPERATION

Flip-up Chute

This allows for:

1. Trailer towing.
2. Discharge of unused material in a pile.
3. Ground storage without stands.
4. More ground clearance when not in use.

Adjusting spread pattern

Use the multiple holes and links on the three chute deflectors to adjust the width of the spread pattern. You can also control the spread pattern by speeding up or slowing down the spinner with the in-cab control.

The spreader is designed to spread salt. The hopper vibrator kit is recommended if mixing with sand. The recommended salt-to-sand mix is 50%

PREVENTIVE MAINTENANCE

1. Bearings: the Fast-Cast 600 only has 3 bearings, one at the front of the spreader and two on the spinner shaft. A high quality grease with an operating range of -30° F to 250° F should be used. Bearings should be greased after every 10 hours of use. Prior to greasing, wipe grease fitting area clean of dirt and contaminants. Just enough grease should be pumped in to show a little grease out of the seal.
2. After first 10 hours of operation, check all fasteners, as some loosening is possible.
3. The environment in which the spreader is used is harsh and corrosive. Particular attention should be paid to the electrical connections. In addition to rubber boots sealing the motor terminals, they are coated with dielectric grease when shipped from the factory. Inspect all of the electrical connections, looking for signs of corrosion. Clean and regrease as needed. Most problems that occur with the spreader are electrical and can be prevented just by keeping the connections clean.
4. OFF-SEASON STORAGE: We strongly suggest you not ignore the following instructions.
 - Wash the entire unit thoroughly
 - Grease each bearing, see periodic maintenance.
 - Apply grease to the outside of each bearing, spinner shaft and spinner motor shaft coupling.
 - Remove the discharge chute and store indoors
 - Cover the spreader if it is left outside

NOTE: There is no need to change the gear motor oil as it is lifetime lubricated.

Parts list (see next page for spinner detail)

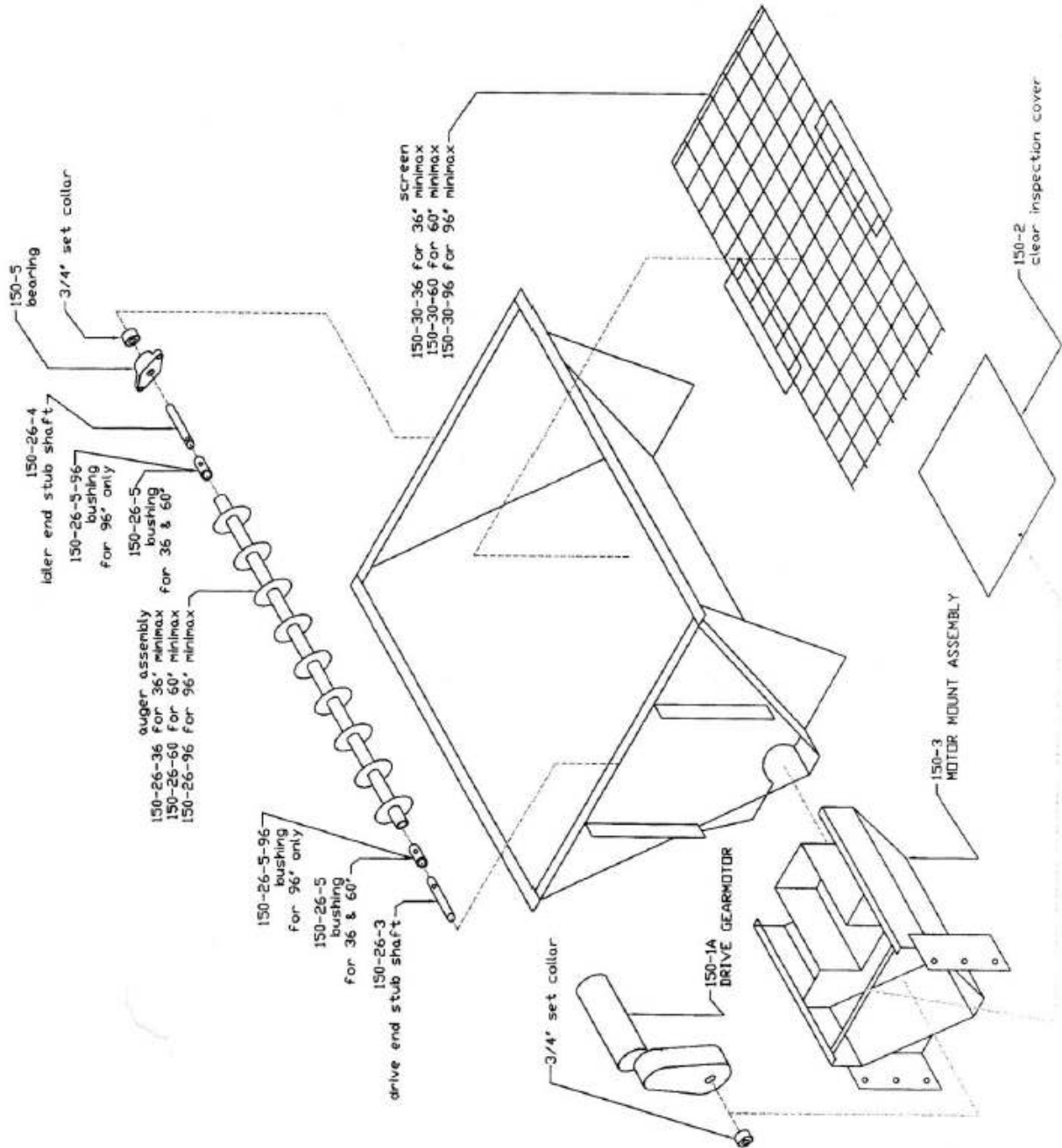

Parts list

