

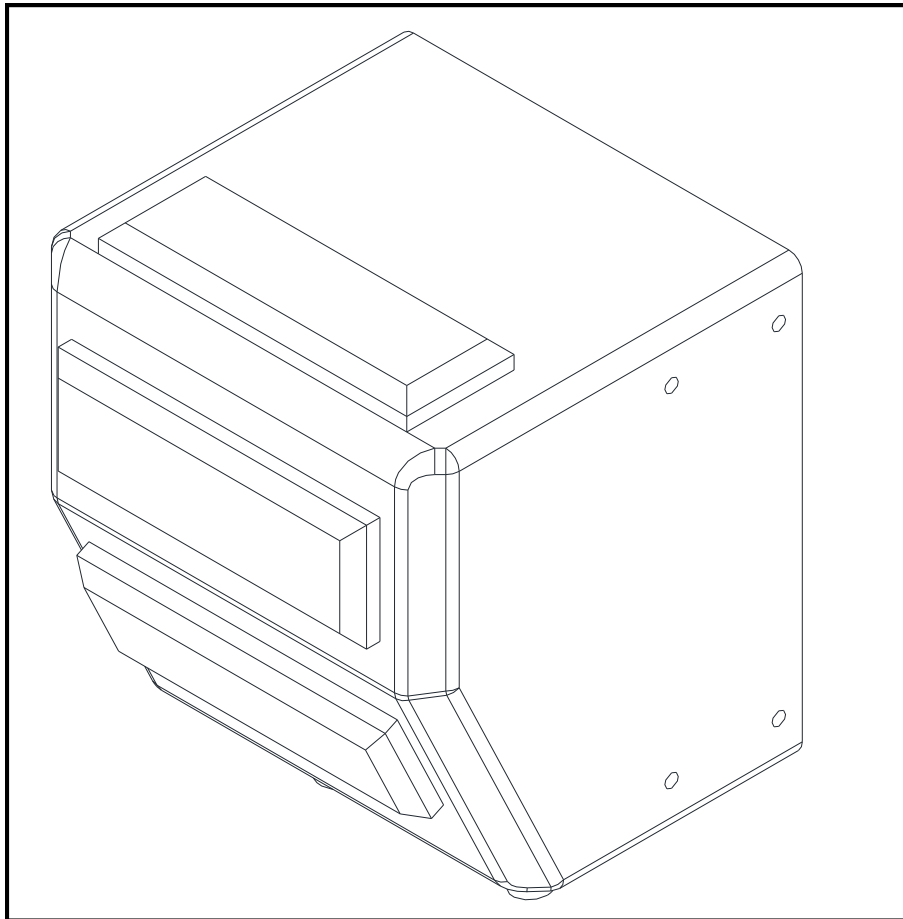

**JOHN DEERE 1 FAMILY  
HEATER KIT  
p/n: 9PH20S59  
fits 1023E, 1025R, 1025R FILB**

The contents of this envelope are the property of the owner.  
Be sure to leave with the owner when installation is complete.

APPROXIMATE INSTALLATION TIME: 1.5 HOURS



(03/03/2020)

p/n: IM-9PH20S59



### STEP 1: HEATER INSTALLATION:

- 1.1 Remove plugs (if equipped) from heater inlet and outlet tubes.
- 1.2 Per **fig. 1.2**, cut two pieces off of the supplied heater hose approximately 3 inches long (to keep the 90-degree elbows as close to the heater core as possible). Install to heater with small hose clamps provided and install 90-degree elbows to the other end of the hoses with small hose clamps. Leave these clamps loose for now. Keep elbows as close to heater as possible.
- 1.3 The location for the heater unit is on the right unitized side frame. Install the heater to the heater bracket, using three of the 1/4" OEM bolts on the side of the heater.
- 1.4 Remove plugs from the right front leg and install plastic bushings from the heater kit by pushing into the holes from the outside of the cab.

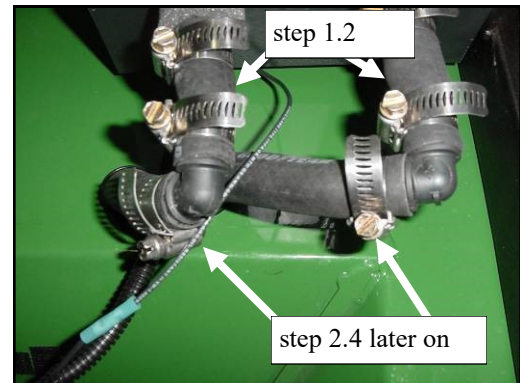

FIGURE 1.2

### STEP 2: HEATER PLUMBING:

\*\*\* **CAUTION** \*\*\* To avoid injury caused by hot engine coolant, make sure the engine is completely cooled down before beginning installation of auxiliary heater.

- 2.1 Remove side engine covers and drain the cooling system.
- 2.2 Per **figures 2.2.1 and 2.2.2**, remove the plug and sealing washer from the left side of the thermostat housing. Install the plug and sealing washer in the end of the sending unit adaptor. Install a nylon washer onto the other end of the sending unit adaptor and install into the engine block where the plug and sealing washer were removed. If the sending unit adaptor does not tighten so that the port on the side for the 3/8" NPT nipple orients as shown, then remove it and install another nylon washer and try again. Install the 3/8" NPT nipple into the side port of the adaptor using Teflon tape (not provided).



FIGURE 2.2.1



FIGURE 2.2.2



## STEP 2: HEATER PLUMBING: (cont'd.)

- 2.3** For the return line from the heater, cut the lower radiator hose in the location shown and install the enclosed T-fitting with large hose clamps provided. **(SEE FIG. 2.3)**
- 2.4** Cut the supplied heater hose in half. Feed the hoses through the plastic bushings in the right front leg of the cab and connect to the heater elbows with small hose clamps. **(SEE FIG. 2.4)** Tighten the hose clamps installed on both sides of the elbows at this time.
- 2.5** Per **figure 2.5**, run the hoses down the right side of the engine. Run the return line to the T-fitting installed in step 2.3. Run the supply line to the sending unit adaptor. Check hose routing making sure it is not kinked or rubbing against any sharp edges. Also make sure the hoses will not interfere with installing the engine side covers. Trim hoses to length and attach to T-fitting and the nipple on the sending unit adaptor **(SEE FIGURES 2.2.1. AND 2.2.2 ON PREVIOUS PAGE)**. Secure hoses as necessary with large wire ties provided.
- 2.6** Splice into the heater supply line and install the in-line shut-off valve. Reference **figure 2.5**. **NOTE:** The in-line shut-off valve quickly converts the heater into a summer time blower by preventing hot water from flowing to the heater core. Tie off hoses as required with large wire ties provided. Refill the cooling system. Start the tractor and inspect system for leaks.

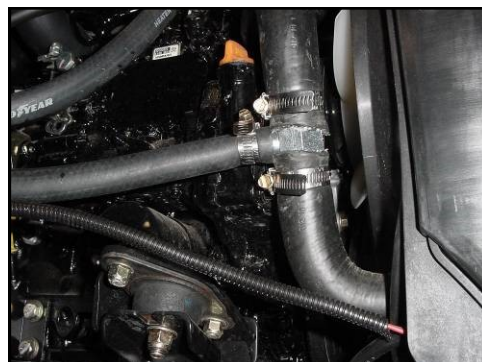

FIGURE 2.3

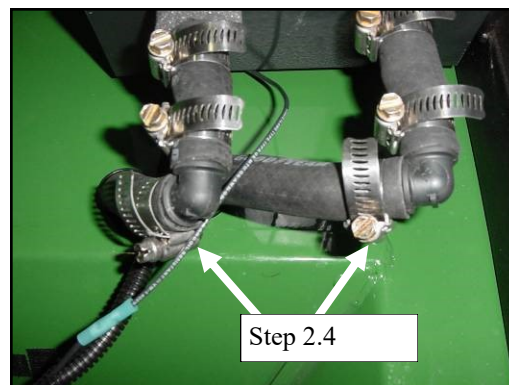

FIGURE 2.4

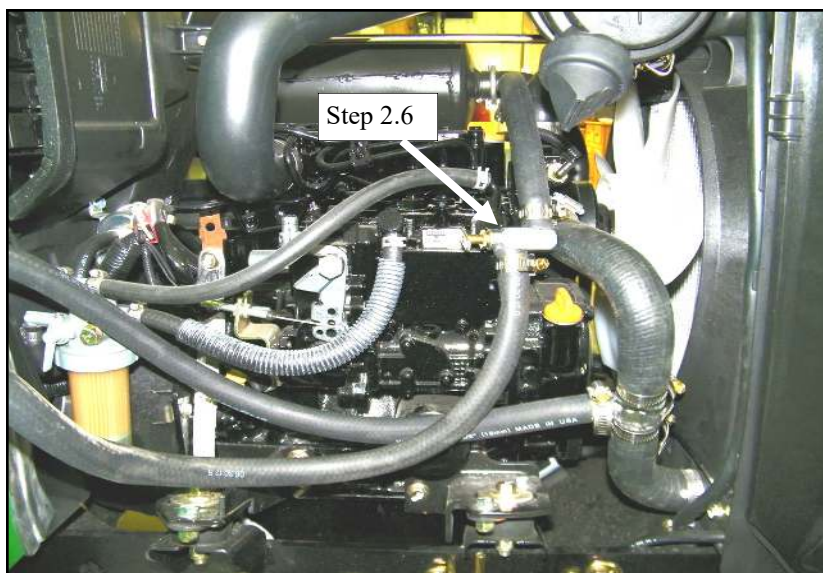

FIGURE 2.5



### STEP 3: ELECTRICAL CONNECTIONS:

- 3.1. Remove the rectangular plug from the windshield support. Per **figure 3.1**, put the large connector through the hole. Matching colors, connect the two wires from the harness to the terminals on the switched power harness. Plug the switch into the connector.
- 3.2 Per **figure 3.2**, snap the switch into the hole with the light bulb toward the center of the vehicle and snap the red switch cover into place.
- 3.3 Per **figure 3.3**, run the wiring down the right side frame rail following the power harness wire. Secure the wiring to the power harness wire with small wire ties provided.
- 3.4 Connect wire harness to heater, connect the red wire from the heater to the yellow wire on the harness and match the remaining wire colors.

### STEP 4: FINISHING TOUCHES

- 4.1 Start the engine and check heater hoses and make sure they get warm. If not, remove the heater from its mount and let hang from hoses as low as possible. If the heater and hoses still do not get warm, temporarily put a clamp on the upper radiator hose to force coolant through the heater. **Warning: To avoid engine damage, remove the clamp as soon as heater gets warm.** Reattach heater to the bracket.



FIGURE 3.1



FIGURE 3.2



FIGURE 3.3





### **HEATER SERVICE PARTS**

(Note: some service part quantities may be higher than the original heater kit contains. This service parts offering is not a packing list.

<b><u>PART NUMBER:</u></b>	<b><u>DESCRIPTION and (qty.)</u></b>
8SV-9PH20WG	20,000 BTU HEATER (qty.: one)
IM-9PH20S59	HEATER MANUAL (qty.: one)
9SV-OHC6	HEATER SWITCH (qty.: one)
9SV-9PCD1B	HEATER SWITCH COVER (qty.: one)
9SV-KX9HTRWH1	HEATER WIRE KIT (qty.: one)
9SV-HRH61-20	HEATER HOSE (qty.: 20 feet)
9SV-9HR00601.0	1" HOSE CLAMPS (set of 6)
9SV-9HR00601.5	1.5" HOSE CLAMPS (set of 2)
9SV-9HR0045	3/8" NPT NIPPLES (set of 2)
9SV-PH20S30P7	SENDING UNIT ADAPTOR (one sending unit and 3 washers)
9SV-HR0039	HEATER HOSE ELBOW (qty.: one)
9SV-9HR-00005	1-1/8" T-FITTING (qty.: one)
9SV-UHTRILV	IN-LINE SHUT-OFF VALVES (set of 2)
9SV-9DPSB	SNAP BUSHINGS (set of 2)