

# CAB INSTALLATION INSTRUCTIONS

JOHN DEERE 2320/2520/2720

HARD SIDED CAB ENCLOSURE (p/n: 1JD2520AS)

SOFT SIDED CAB ENCLOSURE (p/n: 1JD2520SS)

The contents of this envelope are the property of the owner.  
Be sure to leave with the owner when installation is complete.



Note: soft sided cab shown on model 2320 with optional work lights and optional strobe light.

**WARNING** This Curtis Cab is designed and manufactured for use only as reasonable weather protection. This cab is not applicable. Nor should the cab be considered as protection against roll over, collision or other accidents that may result. This cab is **NOT** a R.O.P.S. cab. Extreme care should be taken when operating and by qualified, experienced operators only.

**WARNING** Exposure to Carbon Monoxide can Cause illness, serious injury or death. Never operate vehicle if suspicious of Carbon Monoxide. Inspect exhaust system for leaks monthly. Leaks can result from loose connections, corrosion, cracks or other damage to the exhaust manifold. If leaks are found, repair or replace exhaust system. Do not use vehicle until repair or replacement is complete.

**ADDED WEIGHT NOTICE**  
Curtis Cabs, blades and general accessories add additional weight to the base vehicle. All Curtis accessory weights are listed in product brochures. Deduct the accessories total weight from the vehicles rated capacity and never exceed the vehicles rated capacity including driver and passenger.

# **CURTIS** DESIGN CONCEPT

*Curtis Cabs feature an assembly of parts designed for your vehicle which require adjustment and alignment of components to accommodate vehicle variations and provide proper weather protection. For accurate installation, proper operation, and years of satisfaction, please read and understand the installation instructions.*

*From all of us at Curtis, we thank you for choosing our product.*



## **NOTICE**

Curtis Cabs, blades and general accessories add additional weight to the base vehicle. All Curtis accessory weights are listed in product brochures. Deduct the accessories total weight from the vehicles rated capacity and never exceed the vehicles rated capacity including driver and passenger.



**WARNING** This Curtis Cab is designed and manufactured for use only as reasonable weather protection. This cab is not applicable, nor should the cab be considered as protection against roll over, collision or other accidents that may result. This cabs is **NOT** a R.O.P.S. cab. **Extreme** care should be taken when operating and by qualified, experienced operators only.



**WARNING** Exposure to Carbon Monoxide can Cause illness, serious injury or death. Never operate vehicle if suspicious of Carbon Monoxide. Inspect exhaust system for leaks monthly. Leaks can result from loose connections, corrosion, cracks or other damage to the exhaust manifold. If leaks are found, repair or replace exhaust system. Do not use vehicle until repair or replacement is complete.

## **CAB INSTALLATION BEFORE YOU START**

### **HELPFUL REMINDERS:**

- A. Leave all bolts loose for later adjustment unless otherwise specified.
- B. Read and understand all instructions before beginning.
- C. Plastic washers have been supplied to provide a weather seal around all exterior fasteners. The plastic washer should be installed under each bolt head directly against the outside cab surface. Care should be taken not to over tighten the fasteners and damage the plastic washer. Also use metal washers as required.
- D. Apply a clear silicone sealant to seal any minor gaps that may occur due to vehicle variances. For example, windshield cowl to unitized frames.

### **TOOLS REQUIRED:**

3/8" DRIVE RATCHET WITH A 3" EXTENSION  
STANDARD AND METRIC SOCKETS (3/8" DRIVE)  
3/16" ALLEN WRENCH  
ELECTRIC DRILL  
#2 PHILLIPS HEAD BIT TO USE IN DRILL  
#2 AND #3 PHILLIPS HEAD SCREWDRIVERS  
FLAT BLADED SCREWDRIVER  
OPEN END WRENCHES  
SNIPS

## 1. FIRST THINGS FIRST

**1.1** Refer to the parts lists on pages 16, 17, and 18 and segregate which components you will and will not need for your particular make and model tractor.

For 2320: Keep: wider pair of contours  
top filler

Discard: narrow pair of contours  
front leg bottom  
cowl insert

For 2520 and 2720: Keep: narrow contours  
front leg bottom  
cowl insert

Discard: top filler  
wider contours

**1.2** Remove the two grab handles shown in fig. 1.2. At the owner's discretion, these handles can be discarded or re-installed in reverse orientation once the cab installation is complete.



Fig. 1.2 Handles removed

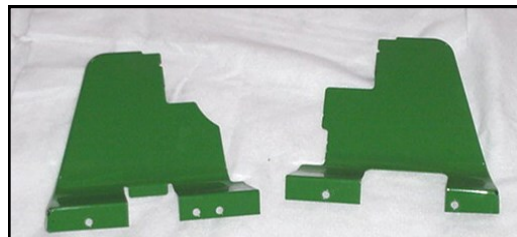

Fig. 1.3 On 2520/2720 only, remove extensions

**1.3** For models 2520/2720 only, remove and discard the floorboard extensions as shown in fig. 1.3. Save 4 of the 6 bolts, flat washers, and split washers for re-use in step 6.1.

**1.4** Adjust the orientation of the two seat belt brackets if they are not set at approximately 45 degrees already. See fig. 1.4. Two-fold reasoning: 1) for clearance for hard sided rear panel to sit properly, 2) the clearance slits in the Behind Seat Filler (black rubber piece) are predetermined to be approximately 45 degrees. To adjust the orientation, simply put a wrench on the head of the bolt and turn the entire bolted assembly a few degrees. No need to loosen the locknut underneath the fender.

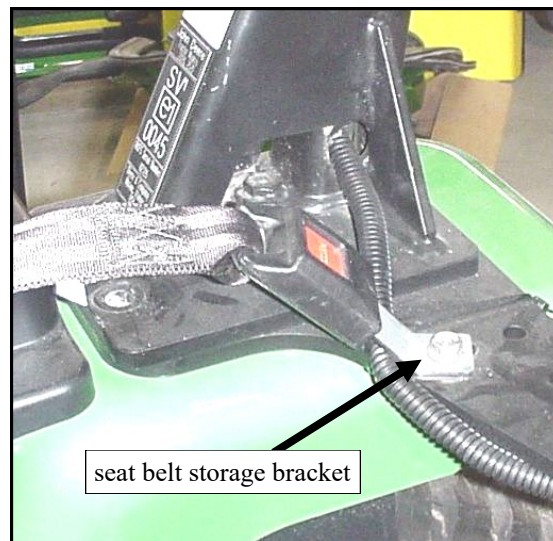

Fig. 1.4 View from left side of vehicle

**1.5** Remove and save for re-use the front four (2/side) original equipment bolts from the base of the ROPS structure as shown in figure 1.5. Note: the vehicle has factory installed inserts (no loose locknuts or washers).

**1.6** For model 2320 only, remove the floorboard bolt closest to the rear fender on each side and discard. See figure 1.6.



Fig. 1.6 View of right side

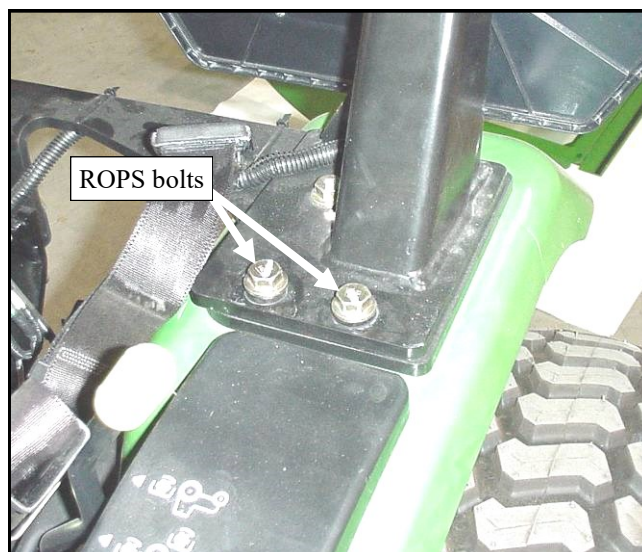

Fig. 1.5 View from left side of vehicle

## **2. BEHIND SEAT FILLER (black rubber)**

**2.1** Note: adhesive-backed velcro should be applied to a clean, dry surface at room temperature. Tip the seat up if it's not already. Lay out the rubber filler as would seem appropriate then apply the self-adhesive hook velcro where needed (i.e.: vehicle fenders, etc.). See figures 2.1 and 2.1.1. Note: fig. 2.1.1 shows a soft side rear curtain in place. The seat belt storage brackets should fit into the clearance slits provided in the rubber. Adhere the behind seat filler to the newly installed velcro strips.

## **3. REAR LEGS**

### **If installing a soft sided cab,**

**3.1** Install the rear leg oriented as shown in fig. 3.1 (with the gussets facing the front and the weatherseal towards the outside of the vehicle). Re-install the 2 original equipment bolts, but do not tighten. Repeat for opposite side.

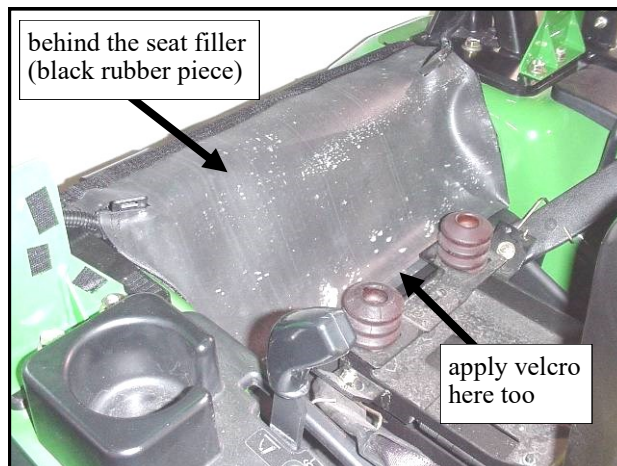

Fig. 2.1 Behind seat filler

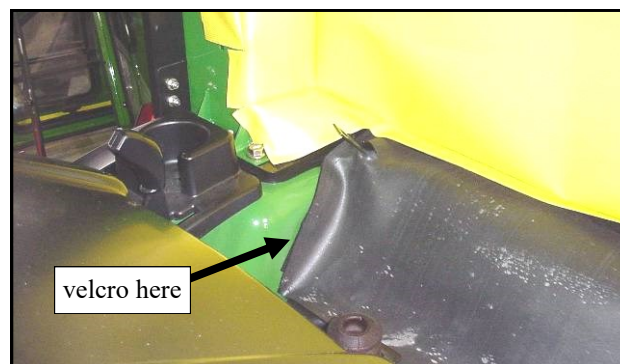

Fig. 2.1.1 View from left side

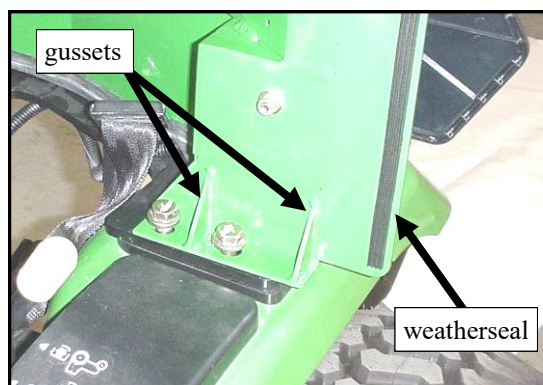

Fig. 3.1 View from left side of vehicle

### 3. REAR LEGS (cont'd.)

#### If installing a hard sided cab,

**On model 2720 only,** remove the items shown in figures 3.2 and 3.3 (storage unit, bracket, and hardware). NOTE: the bracket is press fit onto the ROPS tubing. Pull it off the tubing by hand.

**3.4** Pre-assemble the rear legs to the rear panel as shown in fig. 3.4. Lay the rear panel down on a soft surface with the left and right sides up in the air. Attach each rear leg (to the lower, outboard surface of the rear panel) with three 5/16" x 3/4" long button head bolts, 3 steel washers, and 3 plastic washers on the outside surface and 3 steel washers and 3 locknuts on the inside surface as shown in fig. 3.4. The top holes are to be left open for now (see fig. 3.4.1). Tighten these bolts.

**3.5** Tip the driver's seat forward. With assistance, place the rear panel/rear leg assembly in position as shown in figure 3.5. Note: the bulb rubber on the bottom can be lightly pulled so it is facing out of the cab as you are installing it. Re-install the 4 original equipment bolts, but do not tighten.



Fig. 3.2 Storage unit (on 2720 only)



Fig. 3.3 Storage unit, bracket, and hardware

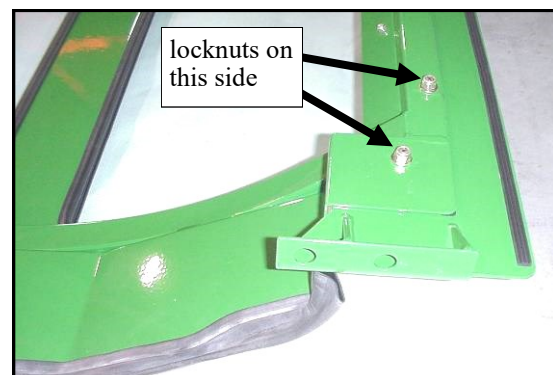

Fig. 3.4 View of bottom of rear panel assembly

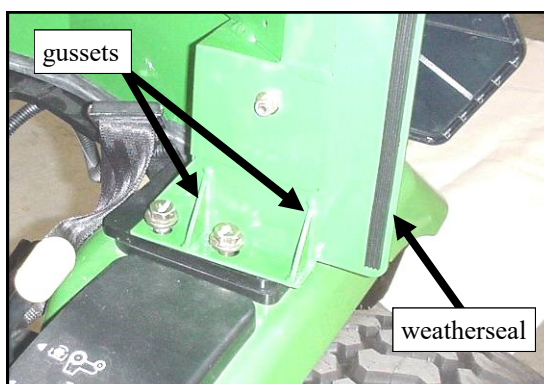

Fig. 3.5 View from left side of vehicle

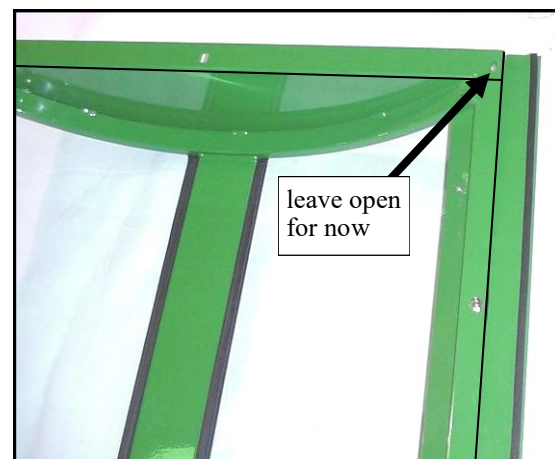

Fig. 3.4.1 View of top of rear panel assembly

## 4. SIDE FRAMES

**4.1** With assistance, temporarily remove the doors from the side frames (for easier handling) by unlatching and sliding up and off the pin hinges.

**4.2** Attach one contour to the inside edge of each side frame using five self-drilling screws. See fig. 4.2. Note: extra screws are provided in case one gets lost. Be sure to select the appropriate contour for the specific tractor model number. The wider pair is for the 2320. The narrow pair is for the 2520/2720. Place the intentional identification notch towards the rear of the side frame (see figure 4.3). Start by using the 1/8" shy of flush approach to the outer radius of the bent tubing and adjust only where necessary to guarantee at least a minimum of 1/4" overhang on the inside radius so there will be sufficient room to accept the bulb rubber to be installed next. Repeat for opposite side.

**4.3** Install the bulb rubber to the sheet metal contour pieces as shown in fig. 4.3.

**4.4** **For 2320 only**, place the supplied 5/8" thick spacer over the hole in the floorboard of the vehicle where the original equipment bolt was removed in step 1.6. Repeat for opposite side.

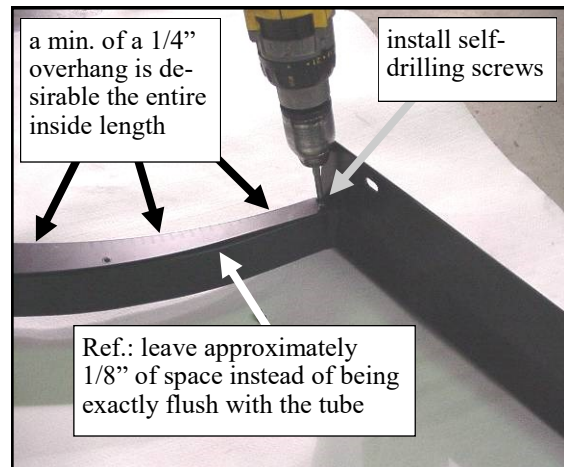

Fig. 4.2 Attaching Contour pieces

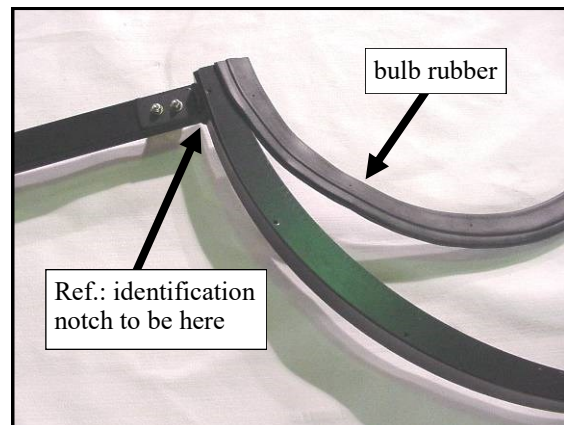

Fig. 4.3 Installing bulb rubber

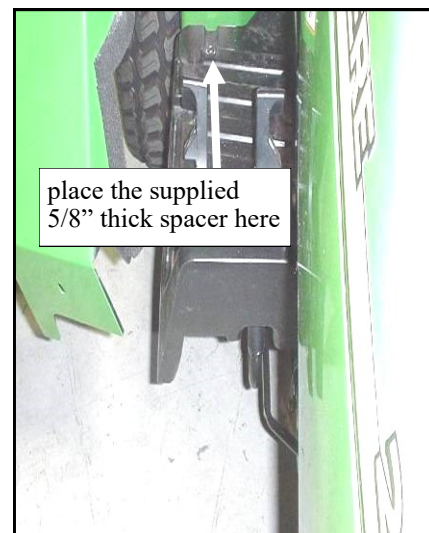

Fig. 4.4 View of right side

#### 4. SIDE FRAMES (cont'd.)

4.5 With assistance, position the side frame onto the vehicle. See fig. 4.5. Use a Phillips head screwdriver to puncture the weatherseal on the rear legs so that bolts can pass through. Only pierce the holes that line up with the factory installed threaded inserts in the back of the side frames for your particular model. Model 2320 uses the top holes. Model 2520/2720 uses the bottom holes. Use the following hardware: three 5/16-18 x 3/4" long button head bolts, 3 steel washers, and 3 plastic washers per side frame. Leave out the top bolts for 2320 only. **On model 2320 only**, be sure the 5/8" thick nylon spacer is in place under the floorboard hole in the side frame. Install the new, longer M8 x 1.25 x 45mm long bolt and washer provided. Do not tighten any of these bolts. **On models 2520/2720 only**, the single floorboard hole on the side frame on each side does not get used.

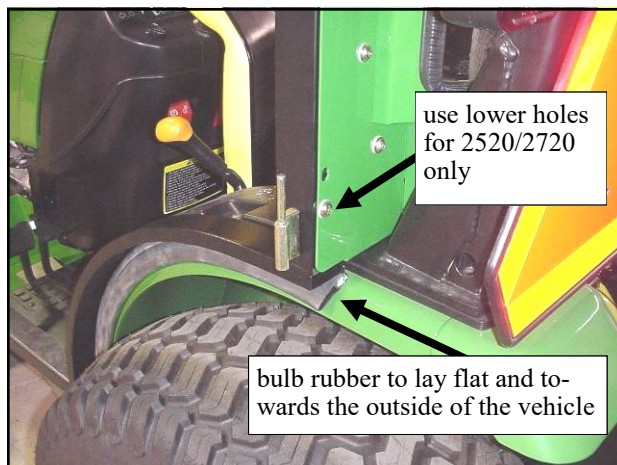

Fig. 4.5 View from left side of vehicle

#### 5. TOP FILLER (for model 2320 only)

5.1 Per fig. 5.1, install the top filler oriented so the long straight edge is up top. Fig. 5.1 shows a soft sided cab installation. The top filler should be sandwiched between the side frames and the rear legs. Use the following hardware: one 5/16-18 x 1" long button head bolt, one steel washer, and one plastic washer per side in the higher of the two slots as shown and into the factory installed threaded insert in the back of the side frame.

5.2 For a hard side cab only, there would be a hard rear panel in place in fig. 5.2. Use the following hardware: add three (3) 5/16-18 x 3/4" long button head bolts, 3 steel washers, and 3 plastic washers to the outside surface and 3 steel washers and 3 locknuts to the inside surface to secure the top filler to the rear panel as shown in fig. 5.2.

5.3 For a soft sided cab only, use only the two end holes (not the middle hole). Use two (2) 5/16-18 x 3/4" long button head bolts, 2 steel washers, and 2 plastic washers to the outside surface and 2 steel washers and 2 locknuts to the inside surface. See fig. 5.2.

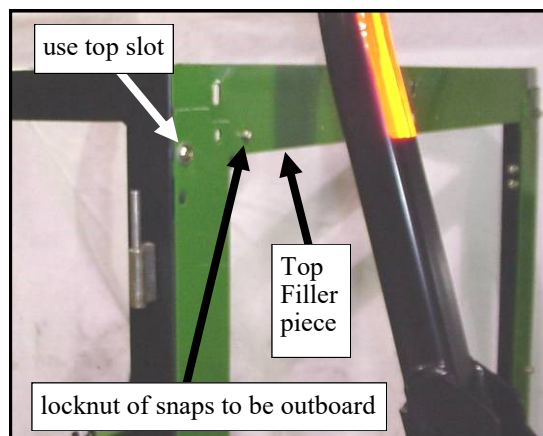

Fig. 5.1 View from left side of vehicle

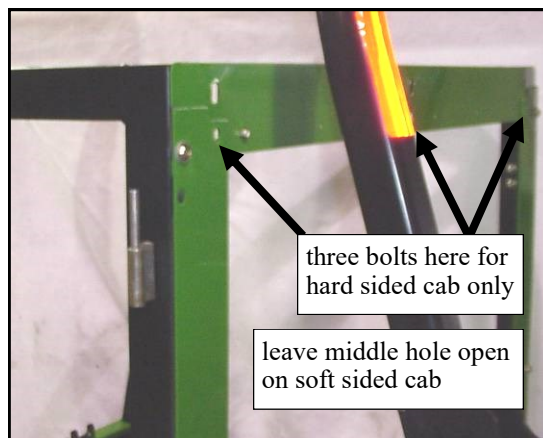

Fig. 5.2 View from left side of vehicle

## 6. COWL

**6.1 For models 2520/2720 only,** remove the two factory installed Heyco plugs and attach the cowl insert to the cowl as shown in fig. 6.1. Note: the 1/2" wide weatherseal is to be against the cowl. Use the following hardware: two 5/16-18 x 3/4" long button head bolts, two steel washers, two plastic washers on the outside surface and two steel washers and two locknuts on the inside surface as shown in the top two holes only. Tighten these bolts. Install the supplied bulb rubber as shown leaving 1 1/2" overhang on both ends. Snip excess as required.

**6.2 For model 2320 only,** leave the two factory installed Heyco plugs in place and attach the bulb rubber directly to the cowl (no cowl insert required). Per figure 6.1, leave 1 1/2" overhang per side and trim excess as required.

**6.3** Install the cowl to the vehicle oriented so the weather-seal goes against the side frame tubing. The bulb rubber in the center should lay forward and outward. See figure 6.3. Attach with the following hardware in the top hole only: one 5/16-18 x 3/4" long button head bolt, one steel washer, and one plastic washer into the factory installed threaded insert on the front of the side frame. Repeat for opposite side.

## 7. FRONT LEG BOTTOM (for 2520/2720 only)

**7.1** Attach the front leg bottoms to the vehicle using 4 of the 6 original equipment bolts, flat washers, and split washers removed in step 1.3. See figures 7.1 and 7.1.1. Finger tighten these 4 bolts for now.

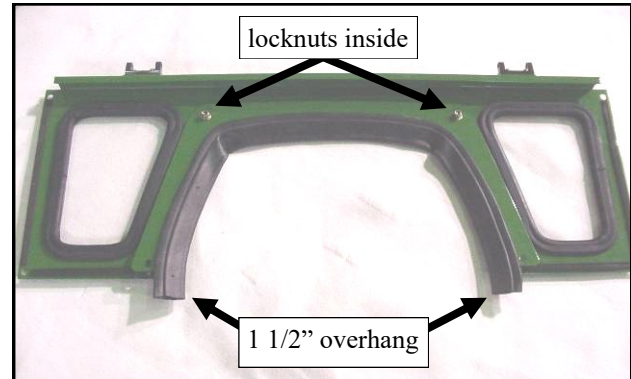

Fig. 6.1 Cowl set up for 2520/2720



Fig. 6.3 Cowl installation

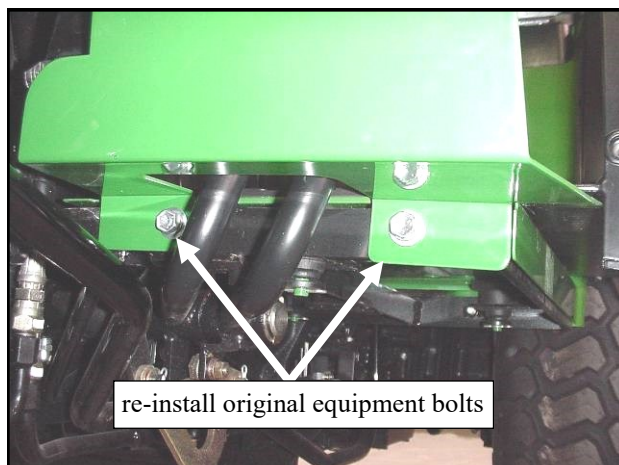

Fig. 7.1.1 Underneath of left side shown

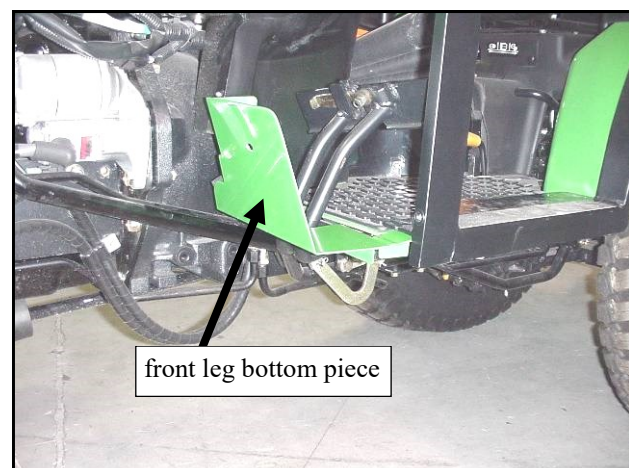

Fig. 7.1 Left side shown



## 8. FRONT LEGS

For all models, leave the black Heyco plugs in place unless installing an optional heater.

**8.1 For model 2320 only**, install the front leg by sliding in from the outside as shown in figures 8.1, 8.1.1, and 8.1.2. The top flange of the front leg goes behind the cowl against the side frame tubing. Caution: handle the front leg with care to avoid damaging the factory installed foam. Reposition the foam after assembly if necessary using a flat bladed screwdriver. Repeat all of step 8.1 for opposite side of vehicle.

**8.2 For models 2520/2720 only**, install the front leg so that the top flange of the front leg is underneath the cowl as shown in fig. 8.1.2. Per fig. 8.1.3, the bent tab on the front leg bottom piece must be inside the front leg as shown. Reposition the foam after assembly if necessary using a flat bladed screwdriver. Repeat for opposite side.

**8.3 For all models**, attach the front leg to the cowl and side frame using three 5/16-18 x 3/4" long button head bolts, three steel washers, and three plastic washers per side on the outside surface. On the inside surface, use one steel washer and one locknut per side. Ref.: two bolts per side thread into factory installed threaded inserts in the side frame tubing. Repeat for opposite side.

**8.4 For models 2520/2720 only**, install one more bolt to the front of the front leg to attach it to the front leg bottom piece as shown in fig. 8.1.3. Use one 5/16-18 x 3/4" long button head bolt, one steel washer, and one plastic washer on the outside surface and one steel washer and one locknut on the inside surface. Repeat for opposite side.

## 9. WINDSHIELD SUPPORT

**9.1** Install the windshield support to the side frames with the bent flange down. Install only the bottom two 5/16-18 x 3/4" long button head bolts, two steel washers, and two plastic washers per fig. 9.1. Two steel washers and two locknuts to be on the inside surface. Note: the top holes will get fasteners once the roof is installed.



Fig. 9.1 Install Windshield Support

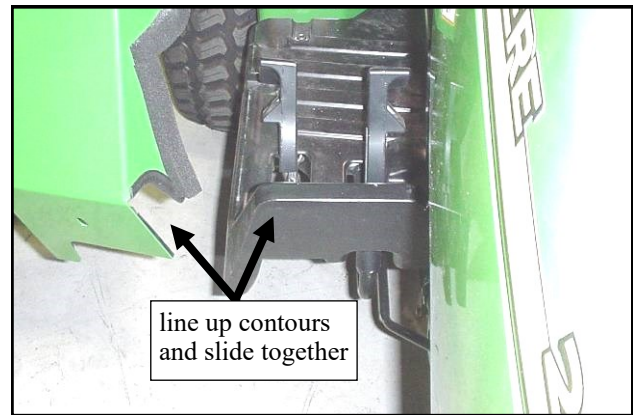

Fig. 8.1 Right Front Leg (model 2320 shown)

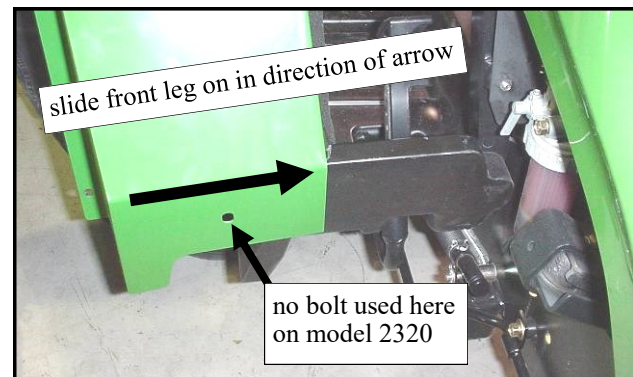

Fig. 8.1.1 Right Front Leg (model 2320 shown)

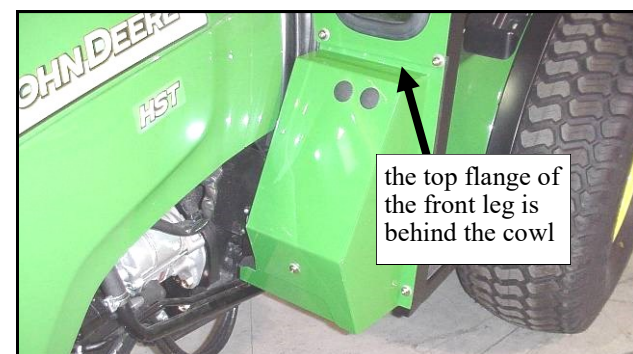

Fig. 8.1.2 Left Front Leg (models 2520/2720 shown)



Fig. 8.1.3 Left Front Leg (models 2520/2720 shown)

## 10. WINDSHIELD

**10.1** With assistance, install the windshield to the windshield support (see fig. 10.1). Use four 5/16-18 x 1 3/4" long flat head bolts, four steel washers, and four lock-nuts. Per fig. 10.1.1, install 3/4" thick plastic spacers between the plastic hinge and the windshield support. Do not tighten.

**10.2** To install the windshield bottom latches into the cowl brackets, open the windshield slightly. Grasp and squeeze the spring-loaded tabs and cradle the latches into the cowl brackets, aligning the tab bosses with their respective mounting holes.

**10.3** To close, grasp the windshield bottom edge and lift slightly while pushing closed. Fully close latches. Align sides of windshield with side frames and tighten hinges. **HINGES ARE PLASTIC COMPONENTS. DO NOT OVERTIGHTEN. TORQUE TO 7 FT.-LBS. MAX.**

## 11. ROOF AND ROLL BAR BRACKETS

**11.1** With a Phillips head screwdriver, poke holes through the headliner from the inside surface to the outside surface. With assistance, install the roof as shown in figure 11.1. Use the following combinations of bolts: the two round holes in the top of the roof use two 5/16-18 x 3/4" long button head bolts, two steel washers, and two plastic washers on the outside surface. These two bolts thread into factory installed threaded inserts in the top of the side frames. The two front middle holes (square) use two 5/16-18 x 3/4" long button head bolts, two steel washers, and two plastic washers on the outside surface and two steel washers and two locknuts on the inside surface. The last two front square roof holes use two 5/16-18 x 1" long button head bolts, two steel washers, and two plastic washers on the outside surface and two steel washers and two locknuts on the inside surface.

**11.2** Per figure 11.2, install two roll bar bracket mounts to the holes in the back of the roof with two 5/16-18 x 1" long button head bolts, four steel washers, and two nylon lock nuts per mount. **Note that the four bolts should have the bolt head on the inside of the cab, so as not to interfere with the soft sided rear curtain.**

**11.3** Install two roll bar brackets with two 5/16-18 x 1" long button head bolts, four steel washers, and two nylon lock nuts per bracket, as shown in figure 11.2.



Fig. 10.1 Windshield installed

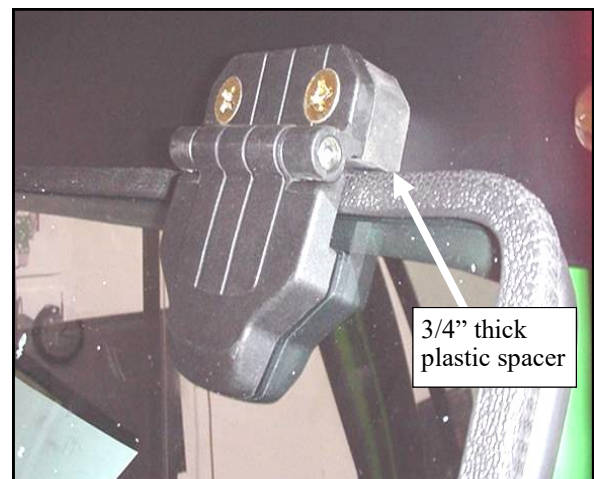

Fig. 10.1.1 3/4" thick spacer block

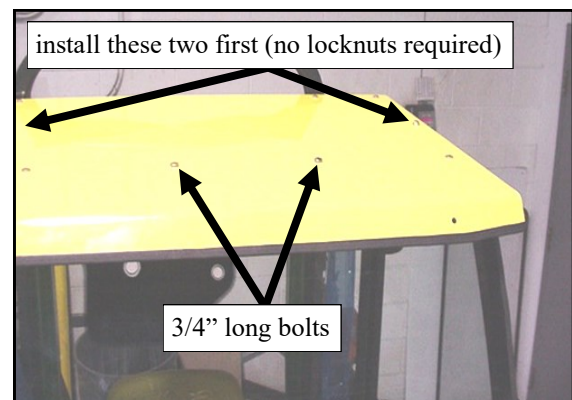

Fig. 11.1 Roof (viewed from the front)

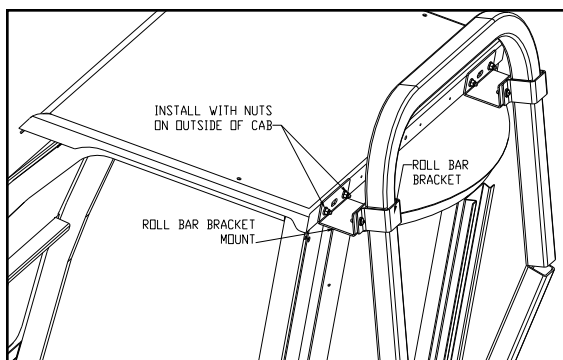

Fig. 11.2 Roof (viewed from the back)

## 12. TIGHTEN ALL BOLTS

**12.1** Tighten all remaining bolts including the floorboard bolts on the 2320 (no floorboard bolts used on the 2520/2720).

**IMPORTANT: the four (4) bolts that were removed and re-installed at the base of the ROPS structure must be torqued properly to meet original equipment safety standards. These four bolts (M14 diameter) are to be torqued to 91-108 ft.-lbs. (124-147 N-m).**

## 13. REAR CURTAIN (soft sided cabs only)

**13.1** For models 2520/2720 only, install the 6 supplied snaps and locknuts to the rear of the roof with the locknuts on the outside surface. Note: extra snaps are provided in case one gets lost.

**13.2** For model 2320 only, install the 6 supplied snaps and locknuts to the top filler piece with the locknuts on the outside surface. Note: extra snaps are provided in case one gets lost. Ref.: see fig. 5.1 on page 6.

**13.3** Attach the top of the rear curtain to the newly installed snaps. See fig. 13.3.

**13.4** Note: adhesive-backed velcro should be applied to a clean, dry surface at room temperature. Apply self-adhesive hook velcro, as needed, along the rear legs and rear panel. See figures 13.4 and 13.4.1. Adhere the rear curtain to the newly applied velcro strips.

**13.5** The bottom of the rear curtain has factory installed velcro for attaching to the top side of the previously installed rubber filler.

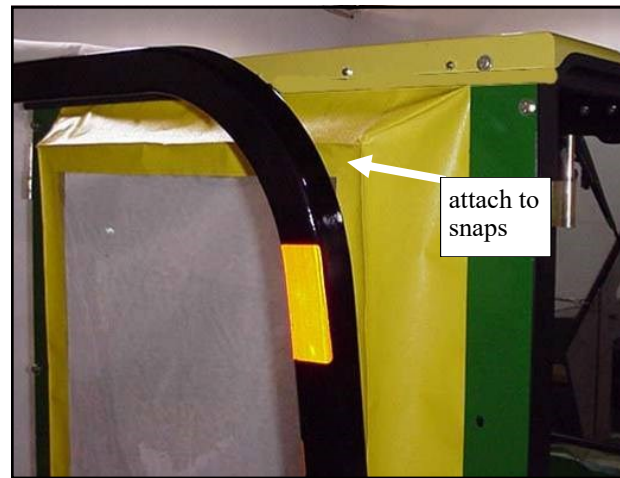

Fig. 13.3 Soft side rear curtain

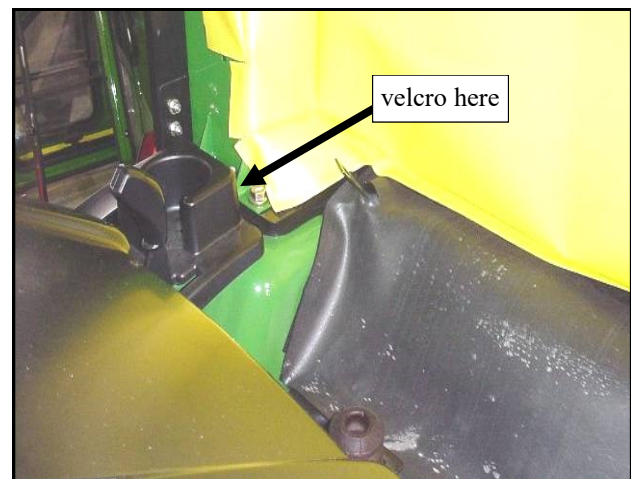

Fig. 13.4 Soft Side Curtain (viewed from left side)



Fig. 13.4.1 Soft Side Curtain (viewed from the back)

## 14. DOORS

**14.1** Apply grease to the pin hinges if desired. With assistance, re-install the doors onto the pin hinges. See figure 14.1. Work the doors back and forth until the hinges are completely seated. Note: the hinges, inside latch, and striker bolt can also be adjusted for proper engagement.

**14.2 For hard sided doors only**, install the gas shock to the frame and door with the small piston end towards the door. Press the button on the compression fastener to lock the gas shock to the ball stud.

**14.3 For soft sided doors only**, install the vinyl coated cable door stop to the welded tabs on the door and side frame. See fig. 14.3. Use the following hardware: four 5/16-18 x 3/4" long hex head bolts, eight steel washers, and four locknuts. Do not tighten down firmly. Allow for free pivoting.



Fig. 14.1 Hard sided door shown

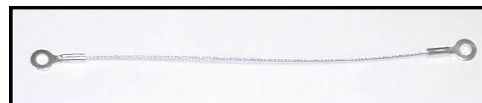

Fig. 14.3 Soft Side door stop

## 15. WIPER (electric)

---

15.1 Install the wiper motor per the instructions included with the kit.

## 16. PLASTIC NUT COVERS

---

16.1 Install the 5/16" plastic nut covers on all the interior locknuts.

## 17. FINISHING TOUCHES

---

17.1 Note: extra hardware has been provided in case some gets lost. Discard extras such as washers and locknuts, etc.

17.2 At the owner's discretion, the two grab handles removed in step 1.2 can either be discarded or re-installed in reverse orientation. See fig. 17.2.



Fig. 17.2 Grab handle (left side)  
(viewed from the front)

## Care and Maintenance Instructions

---

Check and tighten hardware after 40 hours of operation. Periodically inspect and tighten hardware for the remainder of the unit's life.

Wash the painted surfaces of the unit with commercial automotive cleaning products.

Clean windows with glass cleaner.

Vinyl components should be washed with a mild solution of warm soapy water.

Clear vinyl can be easily scratched. Be careful cleaning frost or snow from windows. Do not roll curtains in cold weather. The windows become stiff and may crack. Keep windows clean.

**J.D. 2320/2520/2720 HARD AND SOFT SIDED CAB PARTS LIST (p/n 1JD2520AS and 1JD2520SS)**

**ROLL BAR BRACKET MOUNTS** QTY. P/N  
(COLOR: T-BLACK) 2 8SV-252018-B4

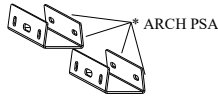

**ROLL BAR BRACKETS** QTY. P/N  
(COLOR: T-BLACK) 2 8SV-252017-B4

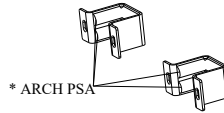

**WINDSHIELD** QTY. P/N  
1 8SV-411002

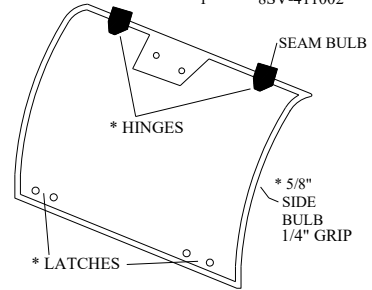

**WINDSHIELD SUPPORT** QTY. P/N  
(COLOR: T-BLACK) 1 8SV411004-B4

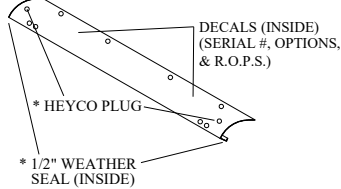

**FRONT LEGS** QTY. P/N  
(COLOR: GREEN) LEFT 1 8SV-252003L-G4  
RIGHT 1 8SV-252003R-G4

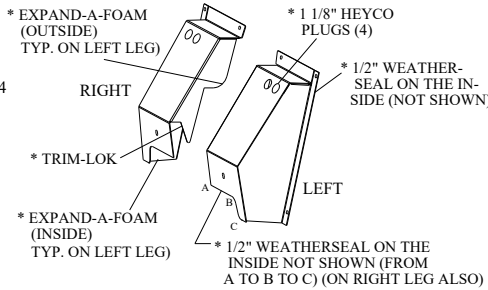

**REAR LEGS** QTY. P/N  
LEFT 1 8SV252011L-G4  
RIGHT 1 8SV252011R-G4

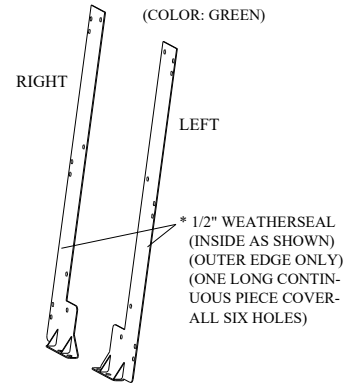

**COWL** QTY. P/N  
(COLOR: GREEN) 1 8SV-252005-G4

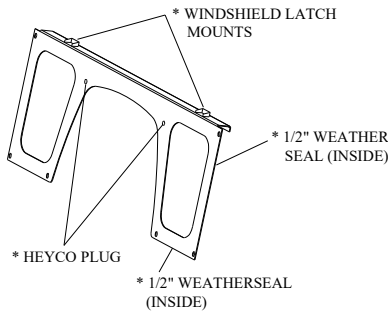

**FRONT LEG BOTTOM** QTY. P/N  
(FOR MODEL 2520 ONLY) LEFT 1 8SV-252008L-G4  
RIGHT 1 8SV-252008R-G4

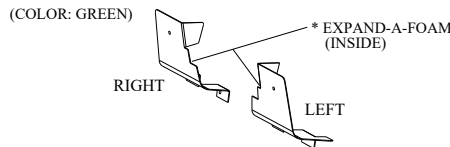

**TOP FILLER** QTY. P/N  
(FOR MODEL 2320 ONLY) 1 8SV252010-G4

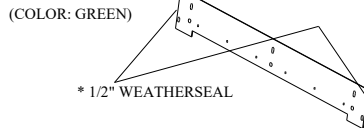

**BEHIND SEAT FILLER** QTY. P/N  
(COLOR: BLACK) 1 8SV252015



**COWL INSERT** QTY. P/N  
FOR MODEL 2520 1 8SV-252012-G4

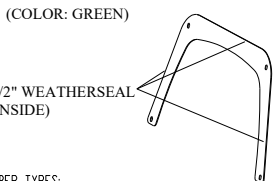

**CONTOURS** QTY. P/N  
FOR MODEL 2320 2 8SV-252013-B4  
FOR MODEL 2520 2 8SV-252014-B4  
(COLOR: T-BLACK)

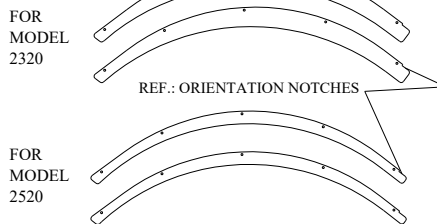

RUBBER TYPES:

ARCH PSA 9SV-PR09-5	1/2" WEATHER SEAL 9SV-PR20-10	3/4" SIDE BULB W/ 1/4" GRIP 9SV-PR38-15
1" FLAT BULB 9SV-PR05-10	1/4" x 3/4" EXPAND-A-FOAM 9SV-PR30-5	

CABS/BLADES/SPREADERS/ACCESSORIES

\* IN HOUSE APPLICATIONS

## J.D. 2320/2520/2720 HARD SIDED CAB PARTS LIST (p/n 1JD2520AS)

ROOF	QTY.	P/N
(COLOR: GREEN)	1	8SV-JD411001-G4

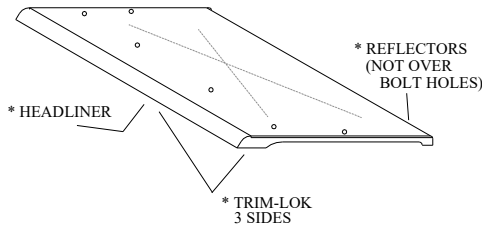

REAR PANEL	QTY.	P/N
(COLOR: GREEN)	1	8SV-252006-G4

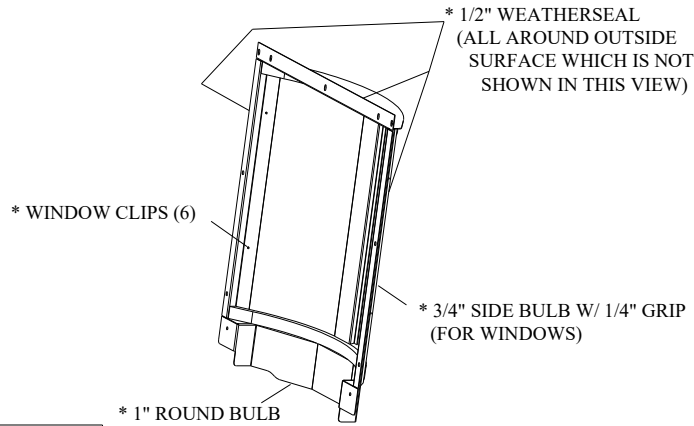

RUBBER TYPES:

1/2" WEATHER SEAL 9SV-PR20-10	3/4" SIDE BULB W/ 1/4" GRIP 9SV-PR38-15	1" ROUND BULB 9PR19	TRIM-LOK 9PR01
----------------------------------	--	------------------------	-------------------

### UNITIZED SIDE FRAMES HARD CAB

	QTY.	P/N
LEFT	1	8SV-2520AS9L-B4
RIGHT	1	8SV-2520AS9R-B4

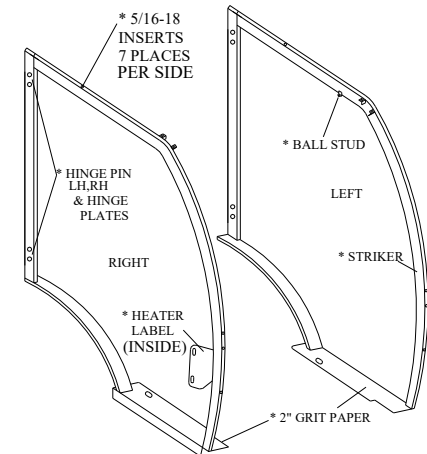

### HARD DOORS

	QTY.	P/N
LEFT	1	8SV-2520AS7L-G4
RIGHT	1	8SV-2520AS-7R-G4

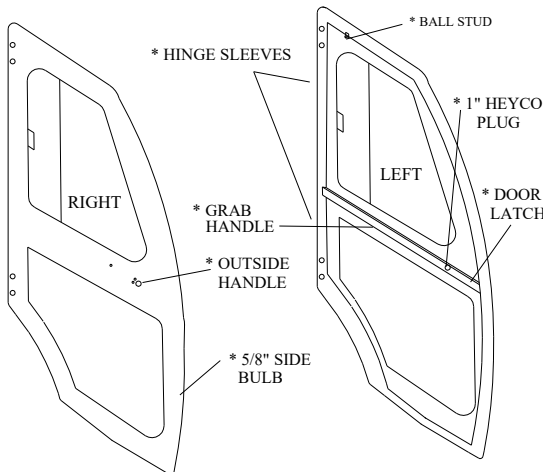

\* IN HOUSE APPLICATIONS

CABS/BLADES/SPREADERS/ACCESSORIES

#### ADDITIONAL SERVICE PARTS

P/N	DESCRIPTION
9SV-HWS	POP OUT WSHIELD HINGE KIT
9SV-WL1	POP OUT WSHIELD LATCH KIT
9SV-HDR1	UNITIZED FRAME HINGE KIT
8SV-SWXL	LEFT DOOR SLIDER ASSEMBLY
9SV-IHRL	RIGHT DOOR SLIDER ASSEMBLY
9SV-DHRL	ROTARY DOOR LATCH KIT
9SV-GS02	OUTSIDE R-LATCH HANDLE W/KEY
8SV-GL14x30	GAS SPRING DOOR (2)
JD2520HWK-01 & 02	REAR PANEL WINDOW (SINGLE)
9SV-GH	HARDWARE KIT (CAB & REAR PANEL)
9SV-DP02	GRAB HANDLE KIT (2)
9SV-DS02	HEYCO PLUG (15)
	CABLE DOOR STOP (13 7/8" LONG)

## J.D. 2320/2520/2720 SOFT SIDED CAB PARTS LIST (p/n 1JD2520SS)

REAR CURTAIN	QTY.	P/N
(COLOR: YELLOW)	1	8SV-252016-VP

ROOF	QTY.	P/N
(COLOR: GREEN)	1	8SV-JD411001A-G4

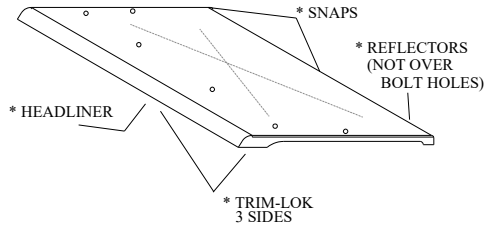

\* FEMALE SNAPS (6) (OUTSIDE)

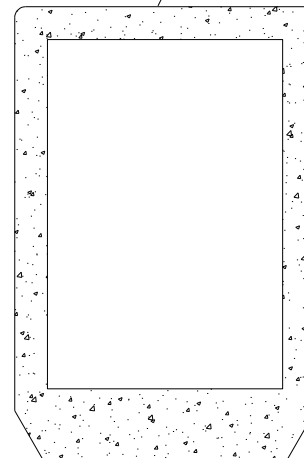

RUBBER TYPES:

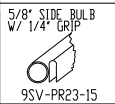

### UNITIZED SIDE FRAMES SOFT CAB

	QTY.	P/N
LEFT	1	JD2520SS-09L
RIGHT	1	JD2520SS-09R

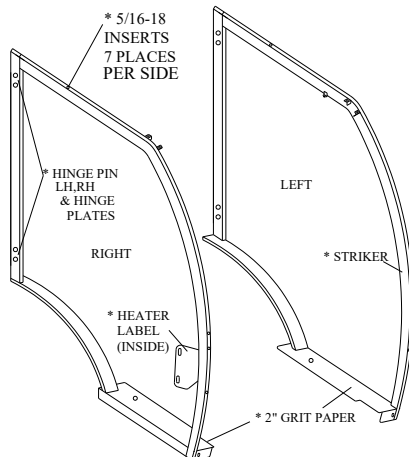

### SOFT DOORS

	QTY.	P/N
(FRAME: BLACK POLY) LEFT	1	8SV-2520SS7L-VP
(VINYL: YELLOW) RIGHT	1	8SV-2520SS7R-VP

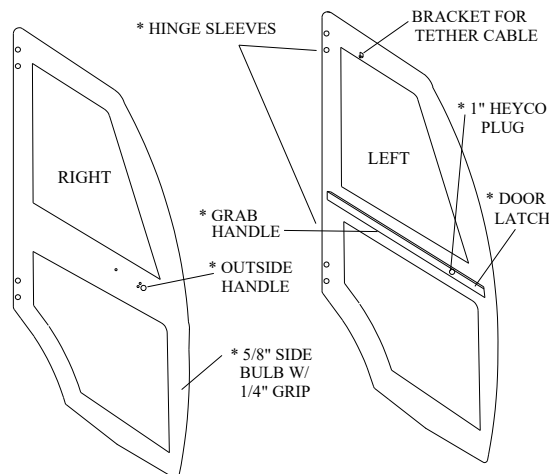

\* IN HOUSE APPLICATIONS

ADDITIONAL SERVICE PARTS

P/N	DESCRIPTION
JD2520HWK-03	SOFT SIDED HARDWARE KIT
9SV-DS02	CABLE DOOR STOP (4)

CABS/BLADES/SPREADERS/ACCESSORIES