



# CAB INSTALLATION INSTRUCTIONS

JOHN DEERE 4000 SERIES (4500/4600/4700)

(4510/4610/4710) (4120/4320/4520/4720)

HARD SIDED CAB ENCLOSURE (p/n: 1JD4120AS)

SOFT SIDED CAB ENCLOSURE (p/n: 1JD4120SS)

The contents of this envelope are the property of the owner.  
Be sure to leave with the owner when installation is complete.



Note: 4510 shown with soft sided cab and optional work lights and optional strobe light.

INSTALLATION & OWNER'S MANUAL

**WARNING** This Curtis Cab is designed and manufactured for use only as reasonable weather protection. This cab is not applicable. Nor should the cab be considered as protection against roll over, collision or other accidents that may result. This cab is **NOT** a R.O.P.S. cab. Extreme care should be taken when operating and by qualified, experienced operators only.

**WARNING** Exposure to Carbon Monoxide can Cause illness, serious injury or death. Never operate vehicle if suspicious of Carbon Monoxide. Inspect exhaust system for leaks monthly. Leaks can result from loose connections, corrosion, cracks or other damage to the exhaust manifold. If leaks are found, repair or replace exhaust system. Do not use vehicle until repair or replacement is complete.

**ADDED WEIGHT NOTICE**  
Curtis Cabs, blades and general accessories add additional weight to the base vehicle. All Curtis accessory weights are listed in product brochures. Deduct the accessories total weight from the vehicles rated capacity and never exceed the vehicles rated capacity including driver and passenger.

**CABS/BLADES/ SPREADERS/ACCESSORIES**

Rev. U, 03/23/23

p/n: IM-1JD4120

# CURTIS DESIGN CONCEPT

Curtis Cabs feature an assembly of parts designed for your vehicle which require adjustment and alignment of components to accommodate vehicle variations and provide proper weather protection. For accurate installation, proper operation, and years of satisfaction, please read and understand the installation instructions.

From all of us at Curtis, we thank you for choosing our product.

**ADDED WEIGHT NOTICE**

Curtis Cabs, blades and general accessories add additional weight to the base vehicle. All Curtis accessory weights are listed in product brochures. Deduct the accessories total weight from the vehicles rated capacity and never exceed the vehicles rated capacity including driver and passenger.









**WARNING** This Curtis Cab is designed and manufactured for use only as reasonable weather protection. This cab is not applicable, nor should the cab be considered as protection against roll over, collision or other accidents that may result. This cabs is **NOT** a R.O.P.S. cab. **Extreme** care should be taken when operating and by qualified, experienced operators only.

**WARNING** Exposure to Carbon Monoxide can Cause illness, serious injury or death. Never operate vehicle if suspicious of Carbon Monoxide. Inspect exhaust system for leaks monthly. Leaks can result from loose connections, corrosion, cracks or other damage to the exhaust manifold. If leaks are found, repair or replace exhaust system. Do not use vehicle until repair or replacement is complete.

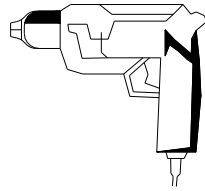
## CAB INSTALLATION BEFORE YOU START HELPFUL REMINDERS:

- A. Leave all bolts loose for later adjustment unless otherwise specified.
- B. Read and understand all instructions before beginning.
- C. Plastic washers have been supplied to provide a weather seal around all exterior fasteners. The plastic washer should be installed under each bolt head directly against the outside cab surface. Care should be taken not to over tighten the fasteners and damage the plastic washer. Also use metal washers as required.
- D. Apply a clear silicone sealant to seal any minor gaps that may occur due to vehicle variances. For example, windshield cowl to unitized frames.

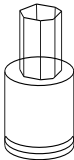
## TOOLS REQUIRED:

				
NO. 2 MEDIUM PHILLIPS HEAD SCREWDRIVER	7/16 IN. 3/8 DRIVE SOCKET	3/8 IN. DRILL BIT	3/8 IN. ELECTRIC HAND DRILL	7/16", 1/2", 7/8", and 1" OPEN END WRENCHES
				
	1/2 IN. 3/8 DRIVE DEEP SOCKET	10MM 3/8 DRIVE SOCKET	3/16 INCH ALLEN DRIVE 3/8 DRIVE	3/8" DRIVE RATCHET

## 1. VEHICLE PREP.

- 1.1 Remove both grab handles (one per side) (see fig. 1.1).
- 1.2 Remove, and discard the outer bolt and nut in each floorboard (see fig. 1.1).
- 1.3 Remove, and **save** two (2) plastic pins (per side) holding the floor mat down (see fig. 1.1).
- 1.4 Tip driver's seat forward.
- 1.5 Drill an oversized hole (3/8" dia.) thru plastic located behind seat and shown in fig. 1.5. The drilled hole is to be exactly over the center of the left weld nut. Transfer the hole location from the bottom up. (Note: take precautions to avoid damaging the metric threads in the nuts welded below.) ( Suggestion: wedge plastic up in the air with a small piece of wood to keep drill bit away from weld nut threads.) This hole will be used to fasten the rear panel assembly in place (ref.: see fig. 2.3.1).

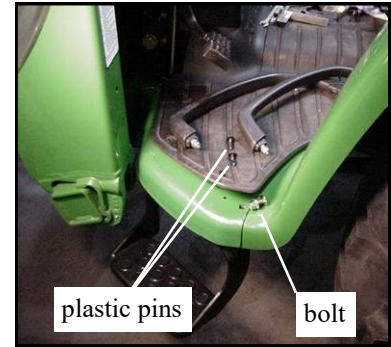

Fig. 1.1 Remove grab handle, bolt, and two plastic pins/side

## 2. REAR PANEL ASSEMBLY

- 2.1 Pre-assemble lower rear panel, rear legs, and rear window support using a total of eight (8) button head screws. (Note: the soft side version does not have a rear window support). See fig. 2.1 for the all steel pre-assembly. To attach the rear window support, use four 5/16" button head screws, steel washers, and nylon washers. To attach the lower rear panel, use four 5/16" button head screws, steel washers, nylon washers, and locknuts.
- 2.2 Install two (2) pieces of 1" round bulb rubber (28" long) on three (3) edges per side as shown in fig. 2.1.
- 2.3 With assistance, and from the side of the tractor, place the pre-assembled unit behind the seat and in between the roll bar uprights (see fig. 2.3). (Make sure the rubber seal that will rest on top of the fenders is facing outwards.) Secure the bottom of the rear panel (thru the newly drilled hole) to the left metric weld nut already in place. (See fig. 2.3.1) Use a 6mm x 1.0 x 20mm long hex. head bolt and 6mm flat washer from the hardware kit.
- 2.4 Secure the lower rear panel to the roll bar using the existing roll bar bolts as shown in fig. 2.4. Attach the rear panel mounts to the rear panel with the locknuts being on the inside of the cab. Use two button head screws, plastic washers, steel washers, and locknuts.



Fig. 1.5 Drill holes in plastic

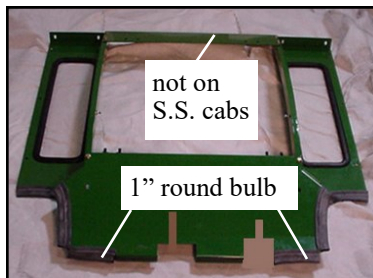

Fig. 2.1  
Pre-assemble  
Rear Panel



Fig. 2.3 Install  
Rear Panel  
Assembly

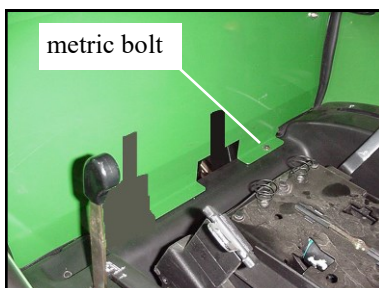

Fig. 2.3.1  
Secure  
Rear Panel



Fig. 2.4  
Rear Panel  
Mount

### 3. FRONT COWL

3.1 **For the 10 Series models**  
**(ref.: 4510, 4610, and 4710):**

Pre-assemble the cowl and the cowl insert using a total of four bolts (5/16-18 x 3/4" long), eight steel washers, four nylon washers, and four locknuts.

Note: fig. 3.1 shows the cowl insert and which four holes to bolt up initially (bolt location "A"). Bolt the cowl insert to the inside surface of the cowl.

Note: the cowl insert and the associated hardware is only required on the 10 Series model numbers listed above.

3.2 Next, bolt the front legs onto the inside surface of the cowl insert so that the cowl insert becomes sandwiched between the cowl and the front legs (bolt location "B"). Attach the front legs using a total of two bolts (5/16-18 x 3/4" long), four steel washers, two nylon washers, and two locknuts. Install 1" bulb rubber (approximately 80") along the sheet metal edges as shown in reference fig. 3.2. Trim any extra bulb rubber.

3.3 **For the 20 Series models**  
**(ref.: 4120, 4320, 4520, and 4720):**

Pre-assemble the cowl and front legs (as shown in fig. 3.2) by fastening together at the inside hole only, using two 5/16" x 3/4" long button head screws, steel washers, nylon washers, and locknuts. Locknuts to be on the inside surface of the cowl assembly. Install 1" bulb rubber (approximately 80") along the sheet metal edges as shown in fig. 3.2. Trim any extra bulb rubber. Note: the cowl insert (shown in fig. 3.1) and the associated hardware is NOT required on the 20 Series model numbers listed above.

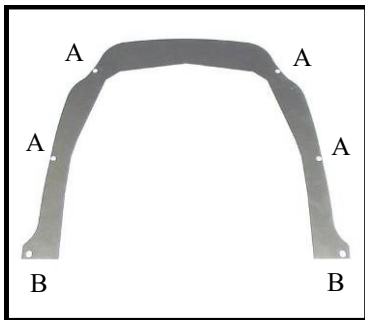

Fig. 3.1  
10 Series  
front cowl insert

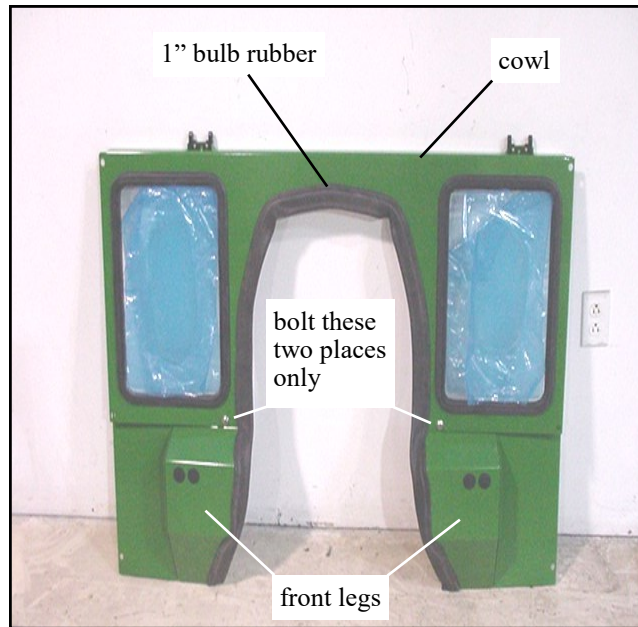

Fig. 3.2  
20 Series front cowl assembly  
(outside surface shown)



### 3. FRONT COWL (cont'd.)

3.4 **For all models**, place the cowl assembly onto the tractor with the flap of bulb rubber extended inward towards the passenger's compartment as shown in fig. 3.4.

### 4. SIDE FRAMES

- 4.1 Remove doors from side frames (for easier handling) by unlatching and sliding up and off the hinge pins..
- 4.2 Install left and right side frames to vehicle as shown in fig. 4.2. The bottom of the side frame is to be on top of the tractor floorboard, but under the rubber mat and under the bottom, bent flange of the front cowl assembly. Fasten to front cowl assembly and rear legs using 5/16 x 3/4" long button head screws, steel washers, and nylon washers. Push the side frame back and install a new, longer floorboard bolt (3/8 x 1 1/2" long carriage bolt), washer, and locknut. The bolt is to pass through the bottom of the side frame and the floorboard.



Fig. 3.4 front cowl installed (20 series shown)

### 5. FRONT WINDSHIELD SUPPORT

5.1 Install the front windshield support to the side frames with the bent flange down. Install only the bottom two 5/16 x 3/4" long button head screws, steel washers, nylon washers, and locknuts. (see fig. 5.1) (Note: the top holes will get fasteners once the roof is installed.)

### 6. WINDSHIELD

- 6.1 With assistance, install the windshield to the windshield support (see fig. 6.1). Use four 5/16 x 1 3/4" long flat head screws and 3/4" thick plastic spacer blocks (placed between the plastic hinge and the windshield support as shown in fig. 6.1.1). Do not tighten.
- 6.2 To install windshield bottom latches into the cowl brackets, open windshield slightly. Grasp and squeeze the spring-loaded tabs and cradle latches into cowl brackets, aligning tab bosses with their respective mounting holes.



Fig. 4.2 Side-frame

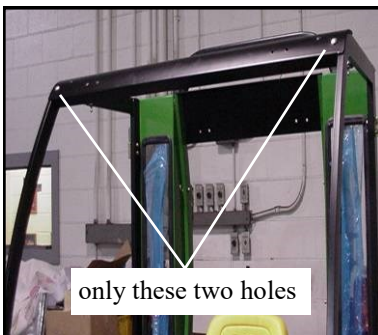

Fig. 5.1 Windshield Support



Fig. 6.1 Install Windshield



Fig. 6.1.1 Spacer Block

## 6. WINDSHIELD (continued)

- 6.3 To close, grasp the windshield bottom edge and lift slightly while pushing closed. Fully close latches. Align sides of windshield with side frames and tighten hinges. HINGES ARE PLASTIC COMPONENTS. DO NOT OVERTIGHTEN. TORQUE TO 7 FT./LBS. MAX.

## 7. ROOF

- 7.1 With assistance, install roof as shown using 5/16 x 3/4" long button head screws, plastic washers, steel washers, and locknuts in all holes except the middle ones on the left and right side (these two bolts do not require locknuts). (see fig. 7.1). (Also note: front left, and front right corners take 1" long bolts)

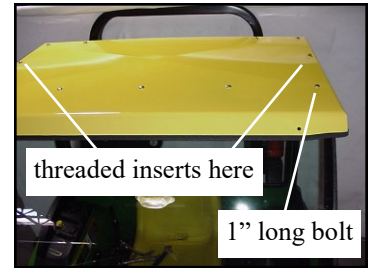

Fig. 7.1 Install Roof

## 8. REAR WINDOW (hard side only)

- 8.1 Install two (2) ball studs to the inner curved surface of the window (Note: the Philips head portion of the screw is to be on the outside of the window.) The base of the ball stud goes against the inner surface of the window, with the boss sitting inside the window hole. Bolt these components together, making sure that the ball portion of the ball stud is facing the outside edge of the window as shown in fig. 8.1.1 (so that the gas shocks will be as close to the edge of the window as possible.)

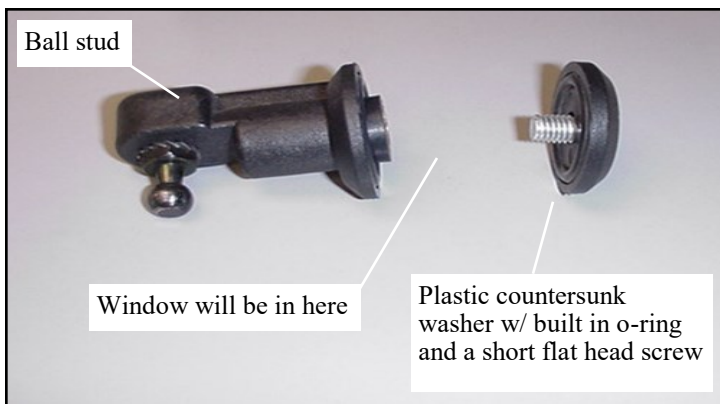

Fig. 8.1 Loose ball stud components

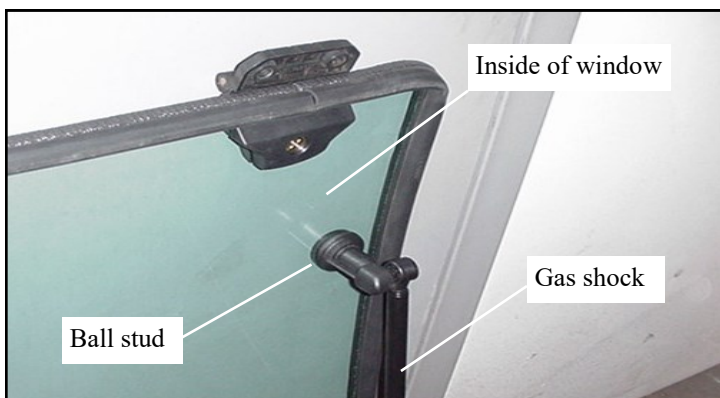

Fig. 8.1.1 Ball stud assembly view

## 8. REAR WINDOW (continued)

- 8.2 Install rear window using same procedure as windshield. Once aligned and tightened, open window and install gas springs to ball studs provided. Release latches from latch mounts and open window all the way in order to snap the gas springs onto the ball studs. (see figures 8.2, 8.2.1, & 8.2.2).  
 Note: rear window has holes for optional wiper.  
 Note: rear window can be opened for ventilation, or latches can be completely released to access rear attachments.

## 9. FLOORBOARD (drill hole)

- 9.1 Line up the hole in the floorboard with the hole in the bottom, bent flange of the front leg. Using these holes as a guide, drill thru the tractor floorboard with a 3/8" drill bit as shown in fig. 9.1.  
 9.2 In this newly drilled hole, install a 5/16 x 3/4" long button head screw, steel washers, and locknut.  
 9.2 Re-install the plastic pins to secure the floor mat.

## 10. DOORS

- 10.1 Install doors onto hinges. (see fig. 10.1) Work the doors back and forth until the hinges are completely seated. (NOTE: the hinges, inside latch, and striker bolt can also be adjusted for proper engagement.)  
 10.2 On hard sided cabs install the gas springs to the frames and doors with the small piston end towards the door. (See fig. 10.2) Press the button on the compression fastener to lock the gas spring to the ball stud.  
 10.3 On soft sided cabs install the cable stops and hardware provided similar to how the gas springs are installed (see 10.2). **WARNING Do not attempt to install gas springs on soft sided doors as this will damage to the doors!**  
 10.4 Tighten all remaining bolts.



Fig. 8.2 Install Rear Window



Fig. 8.2.1 Release latches

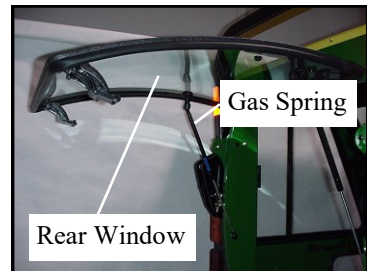

Fig. 8.2.2 Install Gas Springs

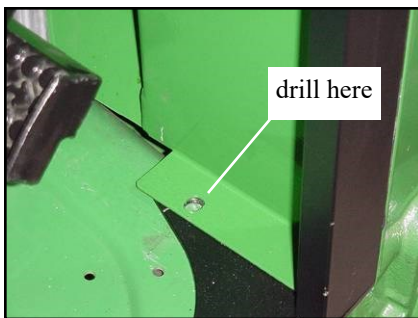

Fig. 9.1 Line up holes



Fig. 10.1 Install Doors



Fig. 10.2 Gas spring installation



## 11. REAR CURTAIN (soft sided only)

- 11.1 Install rear curtain by snapping to the inside back vertical edge of the roof. (see fig. 11.1)
- 11.2 (NOTE: adhesive backed velcro should be applied to a clean, dry surface at room temperature.) Apply self adhesive hook velcro, as needed, along the rear legs and rear panel. Adhere rear curtain to newly applied velcro strips.



Fig. 11.1 Rear Curtain

## 12. FINISHING TOUCHES

- 12.1 Install wiper motor per instructions included with the wiper kit.
- 12.2 Install 5/16" plastic nut covers on all interior 5/16" locknuts.
- 12.3 **For the 00 Series and 10 Series models (ref.: 4500, 4600, 4700, 4510, 4610, and 4710):**  
Install vinyl front fillers by applying self adhesive hook velcro, as needed, along the hood and front legs as shown in figure 12.3. (NOTE: adhesive backed velcro should be applied to a clean, dry surface at room temperature.) (NOTE: left, driver's side shown, repeat for opposite side.) Install front vinyl fillers to newly applied velcro strips.
- 12.4 **For the 20 Series models (ref.: 4120, 4320, 4520, and 4720):**  
Cut the vinyl front fillers as shown in fig. 12.4. Cut along the white lines shown on the photo being sure to cut on the appropriate side of the loop velcro. The photo shows the loop velcro side up. The long cut to be made should follow along the edge of the 5/8" wide loop velcro so the loop velcro remains fully intact on the small piece of vinyl that is labeled "keep for 20 Series". The shorter cut to be made is approximately parallel to the bottom edge as shown (finished product is shown in fig. 12.4.1). Apply self adhesive hook velcro, as needed, along the hood and front legs. (NOTE: adhesive backed velcro should be applied to a clean, dry surface at room temperature.) Install the newly cut (saved) portion of the front filler to the newly applied hook velcro on the vehicle (not shown).
- 12.5 Install the rear filler as shown in fig. 12.5 in the same manner as the front fillers. If your tractor is equipped with a backhoe, cut the filler around the hydraulic lines using snips.

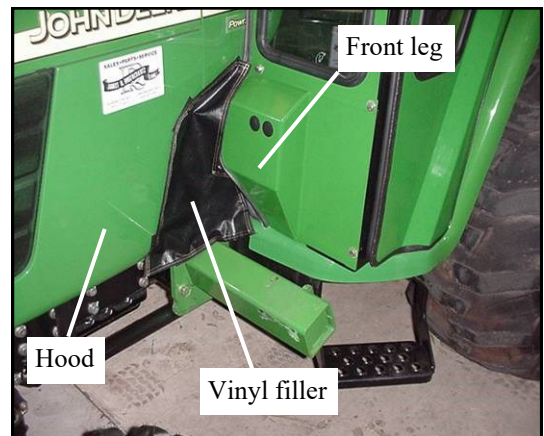

Fig. 12.3  
00 Series and 10 Series front filler installed

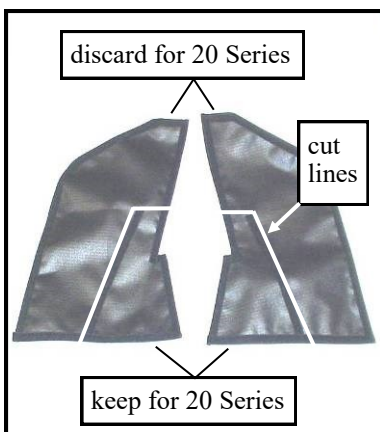

Fig. 12.4  
20 Series front filler prep.



Fig. 12.4.1  
20 Series front fillers  
shown after being cut out  
of larger 00 Series and 10  
Series front fillers

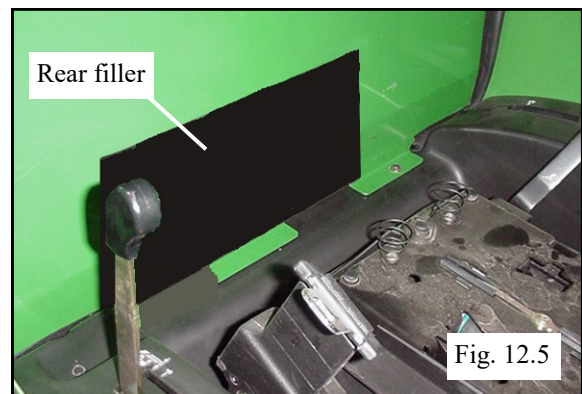

Fig. 12.5





## **Care and Maintenance Instructions**

---

- \* Check and tighten hardware after 40 hours of operation. Periodically inspect and tighten hardware for the remainder of the unit's life.
- \* Wash the painted surfaces of the unit with commercial automotive cleaning products.
- \* Clean windows with glass cleaner.
- \* Vinyl components should be washed with a mild solution of warm soapy water.
- \* Clear vinyl can be easily scratched. Be careful cleaning frost or snow from windows. Do not roll curtains in cold weather. The windows become stiff and may crack. Keep windows clean.

### **IMPORTANT NOTICE**

**On 20 Series models, access Fuel Cap Filler as follows:**

From inside of cab, open both pop-out windshield latches and disconnect latches at spring-loaded finger tabs. Push windshield open far enough to fully open fuel cap filler cover. Close windshield completely but do not reconnect spring-loaded finger tabs on latches at this time.

From outside of cab, fuel tractor being careful to prevent spillage.

When fueling is complete, open windshield far enough to close the fuel cap filler cover. From inside of cab, reattach spring-loaded finger tabs.



## J.D. 4000 SERIES HARD SIDED CAB PARTS LIST (p/n: 1JD4120AS)

ROOF	QTY.	P/N
GREEN	1	8SV-JD451001-G4

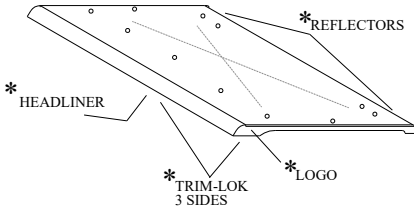

WINDSHIELD	QTY.	P/N
GREEN	1	JD4510-02

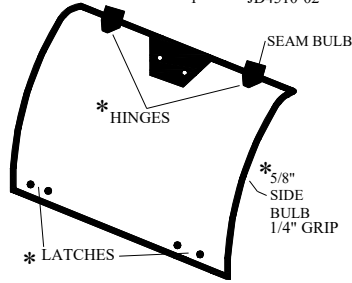

REAR WINDOW	QTY.	P/N
GREEN	1	JD4510-03

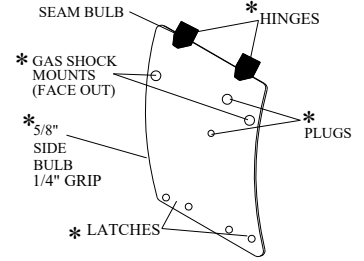

REAR WINDOW SUPPORT	QTY.	P/N
GREEN	1	JD4510-05

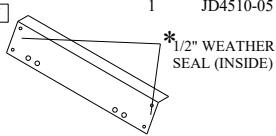

REAR FILLER	QTY.	P/N
GREEN	1	JD4510-16



LOWER REAR PANEL	QTY.	P/N
GREEN	1	JD4510-06A

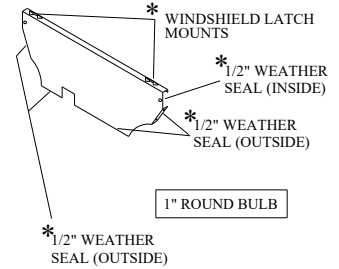

WINDSHIELD SUPPORT	QTY.	P/N
T-BLACK	1	JD4120-04

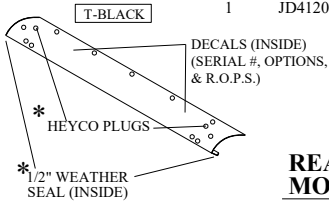

FRONT FILLERS	QTY.	P/N
LEFT	1	JD4120-15L
RIGHT	1	JD4120-15R

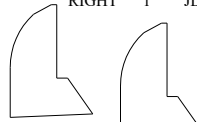

REAR PANEL MOUNTS	QTY.	P/N
T-BLACK	2	JD4510-12



FRONT LEGS	QTY.	P/N
GREEN	LEFT	1 JD4120-10L
GREEN	RIGHT	1 JD4120-10R

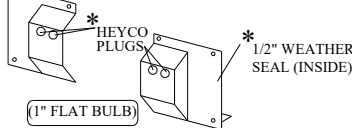

WINDSHIELD COWL	QTY.	P/N
GREEN	1	JD4120-08A

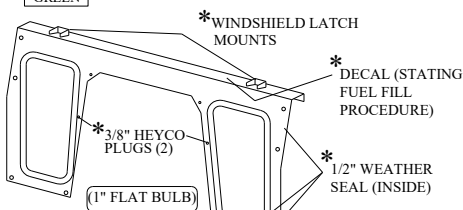

REAR LEGS	QTY.	P/N
GREEN	LEFT	1 JD4510-11L
GREEN	RIGHT	1 JD4510-11R

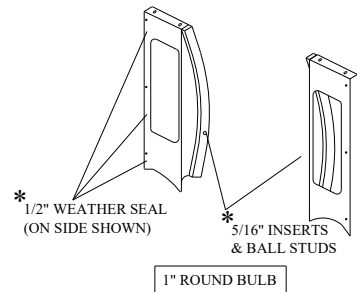

10 SERIES COWL INSERT	QTY.	P/N
GREEN	1	JD3520-17A

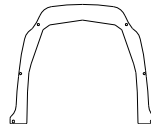

**RUBBER TYPES:**

TRIM-LOK	1/2" WEATHER SEAL	5/8" SIDE BULB	5/8" SIDE BULB W/ 1/4" GRIP	1" FLAT BULB	1" ROUND BULB
9PR01	9PR20	9PR17	9PR23	9PR05	9PR19

UNITIZED SIDE FRAMES HARD CAB	QTY.	P/N
T-BLACK	LEFT	1 JD4510AS-09L
T-BLACK	RIGHT	1 JD4510AS-09R

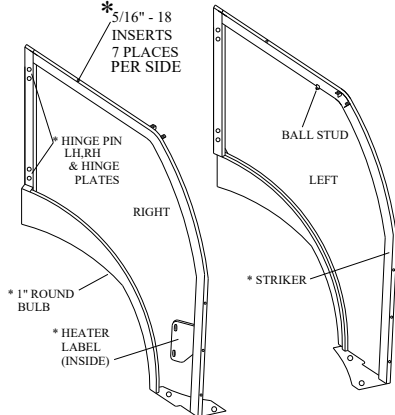

HARD DOORS	QTY.	P/N
GREEN	LEFT	1 JD4510AS-07L
GREEN	RIGHT	1 JD4510AS-07R

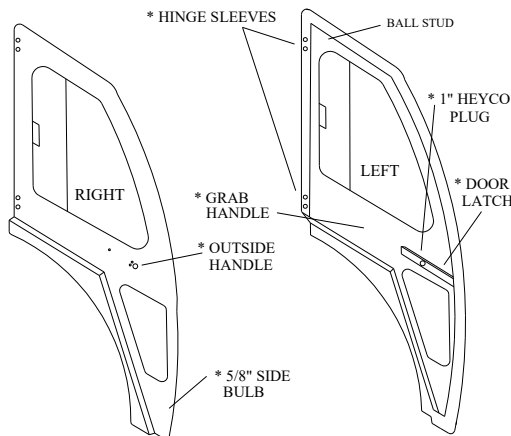

**ADDITIONAL SERVICE PARTS**

P/N	DESCRIPTION
9GL-30X46	MOLDED WINDSHIELD KIT
9PH007 & 9BLK01	PDP OUT WSHIELD HINGE KIT-SINGLE
9WL01	PDP OUT WSHIELD LATCH KIT-SINGLE
9PH006	UNITIZED FRAME HINGE KIT-LH
9PH005	UNITIZED FRAME HINGE KIT-RH
9SW-C2L	LEFT DOOR SLIDER ASSEMBLY
9SW-C2R	RIGHT DOOR SLIDER ASSEMBLY
9DL01A	ROTARY DOOR LATCH-LH
9DL01B	ROTARY DOOR LATCH-RH
9DL01C	OUTSIDE R-LATCH HANDLE W/KEY
9GS02	GAS SPRING DOOR (SINGLE)
9GS01	GAS SPRING REAR WINDOW (SINGLE)
JD4120HWK-01	HARDWARE KIT (REAR PANEL)
JD3520HWK-02	HARDWARE KIT (FRONT PANEL)

\*IN HOUSE APPLICATIONS

CABS/BLADES/SPREADERS/ACCESSORIES



**J.D. 4000 SERIES SOFT SIDED CAB PARTS LIST (p/n: 1JD4120SS)**

ROOF	QTY.	P/N
GREEN	1	8SV-JD451001A-G4

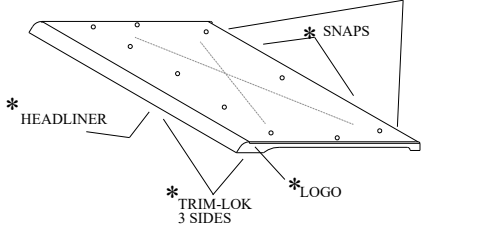

WINDSHIELD	QTY.	P/N
	1	JD4510-02

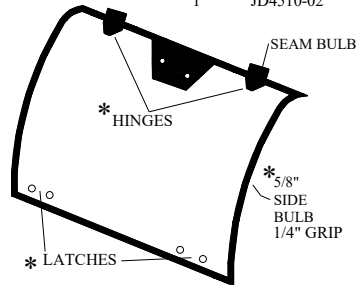

REAR CURTAIN	QTY.	P/N
	1	JD4510-13

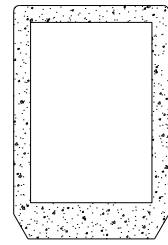

REAR FILLER	QTY.	P/N
	1	JD4510-16



FRONT LEGS	QTY.	P/N
LEFT	1	JD4120-10L
RIGHT	1	JD4120-10R

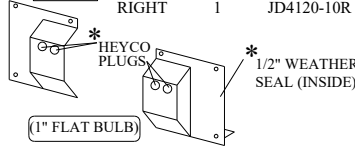

LOWER REAR PANEL	QTY.	P/N
GREEN	1	JD4510-06A

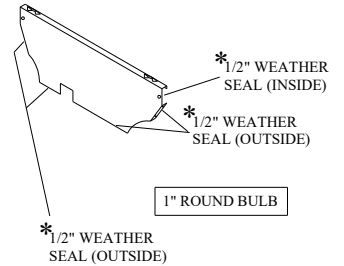

WINDSHIELD SUPPORT	QTY.	P/N
T-BLACK	1	JD4120-04

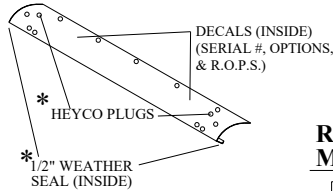

REAR PANEL MOUNTS	QTY.	P/N
T-BLACK	2	JD4510-12



FRONT FILLERS	QTY.	P/N
LEFT	1	JD4120-15L
RIGHT	1	JD4120-15R

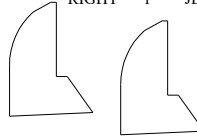

WINDSHIELD COWL	QTY.	P/N
GREEN	1	JD4120-08A

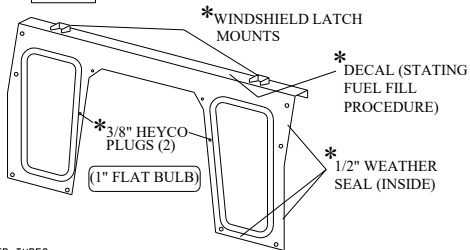

10 SERIES COWL INSERT	QTY.	P/N
GREEN	1	JD3520-17A

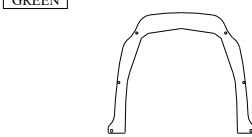

REAR LEGS	QTY.	P/N
LEFT	1	JD4510-11L
RIGHT	1	JD4510-11R

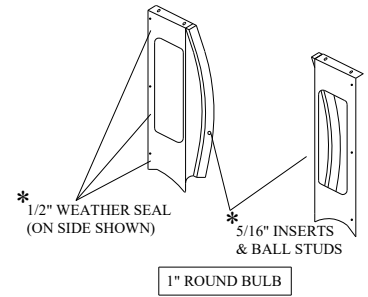

RUBBER TYPES:				
TRIM-LOK 9PR01	1/2" WEATHER SEAL 9PR20	5/8" SIDE BULB w/1/4" GRIP 9PR23	1" FLAT BULB 9PR05	1" ROUND BULB 9PR19

UNITIZED SIDE FRAMES SOFT CAB	QTY.	P/N
T-BLACK	LEFT 1	JD4510SS-09L
	RIGHT 1	JD4510SS-09R

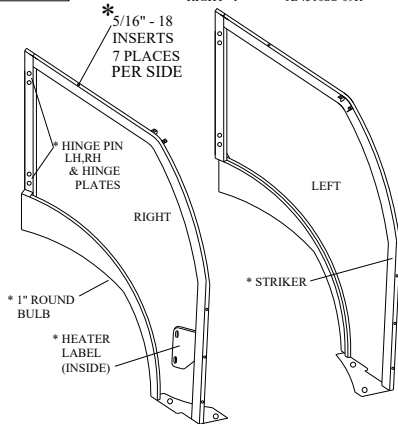

SOFT DOORS	QTY.	P/N
BLACK POLY	LEFT 1	JD4510SS-07L
YELLOW VINYL	RIGHT 1	JD4510SS-07R

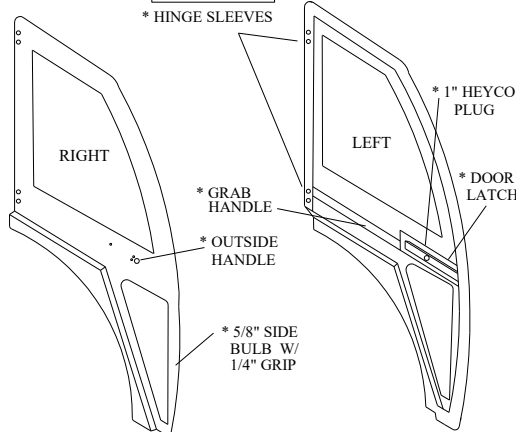

**ADDITIONAL SERVICE PARTS**

P/N	DESCRIPTION
9GL-30X46	MOLDED WINDSHIELD KIT
9PH007 & 9BLK01	POP OUT WSHIELD HINGE KIT-SINGLE
9WL01	POP OUT WSHIELD LATCH KIT-SINGLE
9PH006	UNITIZED FRAME HINGE KIT-LH
9PH005	UNITIZED FRAME HINGE KIT-RH
9DL01A	ROTARY DOOR LATCH-LH
9DL01B	ROTARY DOOR LATCH-RH
9DL01C	OUTSIDE R-LATCH HANDLE W/KEY
JD4510-14L	LEFT DOOR SKIN
JD4510-14R	RIGHT DOOR SKIN
9DS02	DOOR RESTRAINT (2)
JD4120HWK-01	HARDWARE KIT

\*IN HOUSE APPLICATIONS

CABS/BLADES/SPREADERS/ACCESSORIES