



**John Deere Gator XUV/HPX Cab
(fits both HPX and XUV vehicles with factory OPS)
(p/n: 1GTRXUV2) (Steel Cab with Doors) (fits 2006-)**

The contents of this envelope are the property of the owner.
Be sure to leave with the owner when installation is complete.

APPROXIMATE INSTALLATION TIME: 3 HOURS
(excluding accessories)



Standard equipment: Windshield Wiper.

Options available:

Interior Switch Panel Console (p/n: 1GXV2SP)

Interior Rear View Mirror (p/n: 9PM3)

5 LED Flat Work Lights (p/n: 9LEDW4)

Heater (p/n: 9PH20S30)

LED Strobe Light (p/n: 9LEDS2)



Rev. B
9/8/2017
IM-1GTRXUV2

NOTICE

Cabs, blades, and general accessories add additional weight to the base vehicle. Deduct the accessory's total weight from the vehicle's rated capacity including driver and passenger.



WARNING *Exposure to Carbon Monoxide can Cause illness, serious injury or death. Never operate vehicle if suspicious of Carbon Monoxide. Inspect exhaust system for leaks monthly. Leaks can result from loose connections, corrosion, cracks or other damage to the exhaust manifold. If leaks are found, repair or replace exhaust system. Do not use vehicle until repair or replacement is complete.*

⚠ WARNING	
Serious Injury or Death	
	This cab enclosure does not provide protection from rollover or other accidents.
	This cab enclosure does not provide protection from flying objects including golf balls.
	This cab enclosure does not provide protection from lightning. When lightning threatens take cover and do not operate vehicle.

GENERAL INFORMATION BEFORE YOU START

HELPFUL HINTS:

- A. Refer to parts diagram toward the back of this manual to help identify parts during the assembly process.
- B. To assist with the cab installation, leave all bolts loose for later adjustment unless otherwise specified.
- C. Read and understand all instructions before beginning.
- D. Apply a clear silicone sealant to seal any minor gaps that may occur due to vehicle variations.
- E. Use caution to avoid damaging the factory installed threaded inserts. Begin the bolt engagement by hand to guard against potential cross threading.

TOOLS REQUIRED:

Set of Standard Sockets (3/8" Drive)
 One 3/8" Drive Ratchet
 Set of Standard Open End Wrenches
 Phillips Head Screwdriver
 Grease
 3/8" Drill Bit
 Drill

1. REAR PANEL

1.1 Open/lift the dump bed. **Note: If the vehicle has a steel dump bed you must remove the front panel on the dump bed and reinstall it in the angled location so that when closed the front of the dump bed is parallel to the rear of the OPS.**

Note: If you are planning to install rear work lights or 4-way flashers it is easier to pre-install the lights at this time. Please see the instructions in that kit for proper installation steps.

1.2 With assistance, lift the rear panel into place as shown in figures 1.2 and 1.3. The triangular bends should match up to the angles at the top of the OPS.

1.3 Per fig. 1.3, fasten the top of the rear panel to the vehicle using the hardware listed below. **Install finger tight at this time.** **Note: If the vehicle was produced before 2013 use a spacer between the OPS and the mount at the top of the rear panel. Older vehicles use the lower hole. (2013 model shown)**

Qty.	Hardware Type
2	5/16-18 x 3/4" Flange Bolt
2	5/16-18 Nylock Flange Nuts
2	5/16-18 x 2 3/4" Flange Bolt (pre-2013 vehicles)
2	3/8" Nylon Spacers (pre-2013 vehicles)

1.4 Fasten the bottom of the rear panel at the two outer corners using the hardware listed below. **Tighten these two bolts first then the two upper bolts installed in the previous step.**

Qty.	Hardware Type
2	5/16-18 x 3/4" Flange Bolt
2	5/16-18 Nylock Flange Nuts

1.5 See fig. 1.5. Fasten the bottom center of the rear panel behind the seat belts using the hardware listed below. Fender washers should be used on the outside of the rear panel to cover the notches. **Tighten these two bolts.**

Qty.	Hardware Type
2	5/16-18 x 3/4" Flange Bolt
2	5/16-18 Nylock Flange Nuts
2	5/16 ID x 1 1/4" OD Steel Fender Washers



Fig. 1.5 (view from rear of passenger's side)



Fig. 1.2 (view from rear of passenger's side)

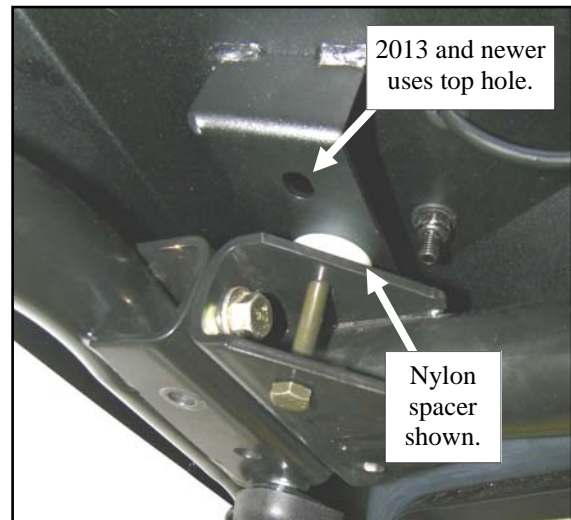

Fig. 1.3 (view of rear passenger's side (pre-2013))

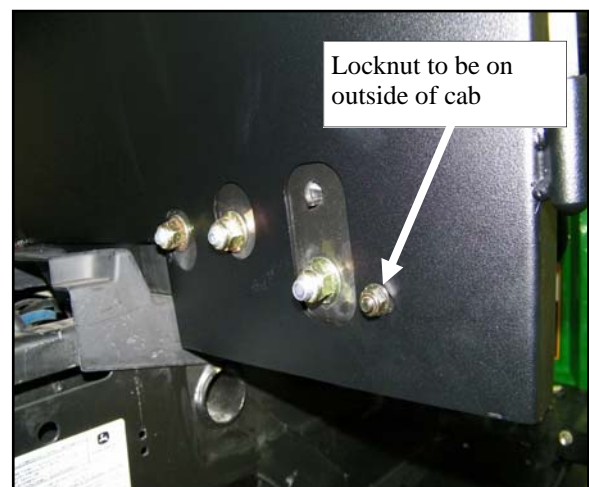

Fig. 1.4 (view from rear of passenger's side)

2. FRONT LEGS

Note: If you are installing the cab on a vehicle produced prior to 2013 you will need to drill 3 holes in each floorboard. See page 11 for dimensions.

2.1 Align the front leg with the front fender on the vehicle, as shown in figure 2.1. Per figure 2.1a, fasten through the hole in the floorboard.

Install finger tight at this time.

Qty. Hardware Type

1 5/16-18 x 3/4" Flange Bolt

1 5/16-18 Nylock Flange Nuts

2.2 Align the front clamps as shown in figure 2.2 with the ball stud at the top. Fasten to the front leg using the hardware listed below. **Note the orientation of the hardware, as shown in figure 2.2. Install finger tight at this time.**

Qty. Hardware Type

3 5/16-18 x 3/4" Flange Bolt

3 5/16-18 Nylock Flange Nuts

Do not install a bolt through the top hole, as this will be installed in a later step.

2.3 Repeat for opposite side.



Fig. 2.1 (view of passenger's side)



Fig. 2.1a (view of passenger's side)



Fig. 2.2 (view of passenger's side)

3. SIDE PANELS

3.1 Align the side panel to the front leg, as shown in figure 3.1. Fasten to the front leg using the hardware listed below. **Install finger tight at this time.**

Qty. Hardware Type

2 5/16-18 x 3/4" Flange Bolt

2 5/16-18 Nylock Flange Nuts

3.2 Fasten side panel to the rear panel using the hardware listed below, as shown in figure 3.2. **Do not tighten screw.** Align the top edge of the rear panel with the back edge of the side panel (see fig. 3.2a). **Tighten the screw.**

Qty. Hardware Type

1 5/16-18 x 3/4" Flange Bolt

Note: Use caution to avoid damaging the factory installed threaded inserts on the rear panel. **Begin the bolt engagement by hand to guard against potential cross-threading.**

3.3 Tighten the front clamp and side panel to the front leg at this time. Be sure to push the front leg down to get a good seal against the vehicle fender.

3.4 Tighten the bolts through the floorboard at this time.

3.5 Repeat for opposite side.

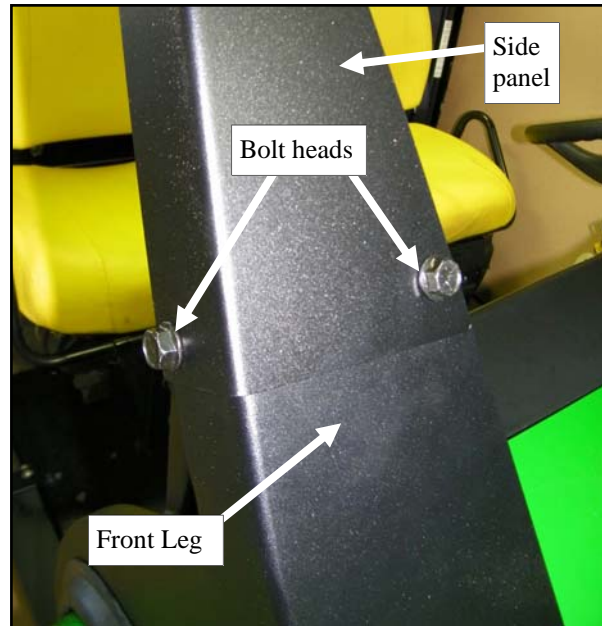

Fig. 3.1 (view of passenger's side)

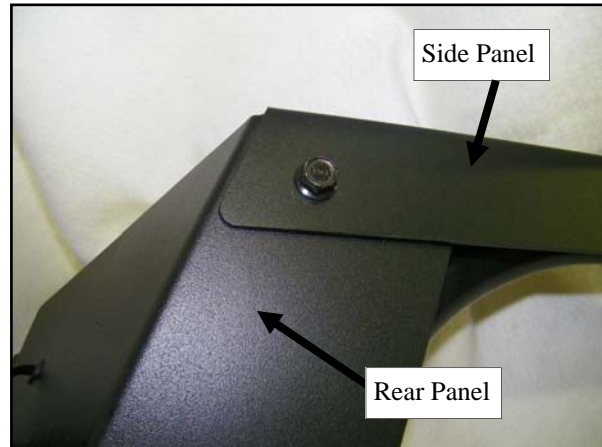

Fig. 3.2 (view of passenger's side)



Fig. 3.2a (view of passenger's side)

4. WINDSHIELD

4.1 With assistance, orient the windshield support as shown in figure 4.1. Fasten to the side panels using the hardware listed below. **Tighten the screws at this time.**

Qty. Hardware Type

4 5/16-18 x 3/4" Flange Bolt

4.2 Set the windshield onto the vehicle and twist the latches to hold it into place. Slide the hinge sleeves onto the windshield hinge pins, oriented as shown in figure 4.2. Fasten using the hardware listed below. **Note: Both the steel and rubber fender washers will be on the inside of the cab in this step, as shown in fig. 4.2a.**

Install finger tight at this time.

Qty. Hardware Type

4 1/4-20 x 3/4" Flange Bolts

4 Rubber Fender Washers

4 Steel Fender Washers

4 1/4-20 Nylock Flange Nuts

4.3 Unlatch the latches on the windshield and adjust the windshield up or down to achieve the optimal seal against the hood. Re-engage the latches to hold it in the correct location.

4.4 Tighten the hinge sleeves. Ref. fig 4.2a.

4.5 With assistance, open the windshield and attach the short gas springs to the ball studs. Orient the springs so that the thin rod end is down as shown in figure 4.5.

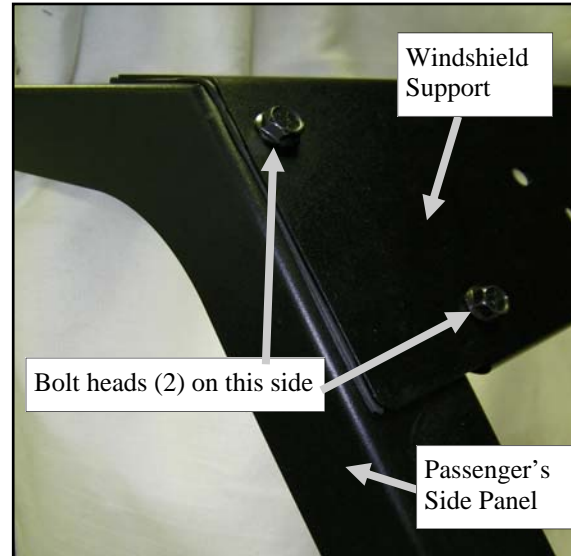

Fig. 4.1 (view of passenger's side)

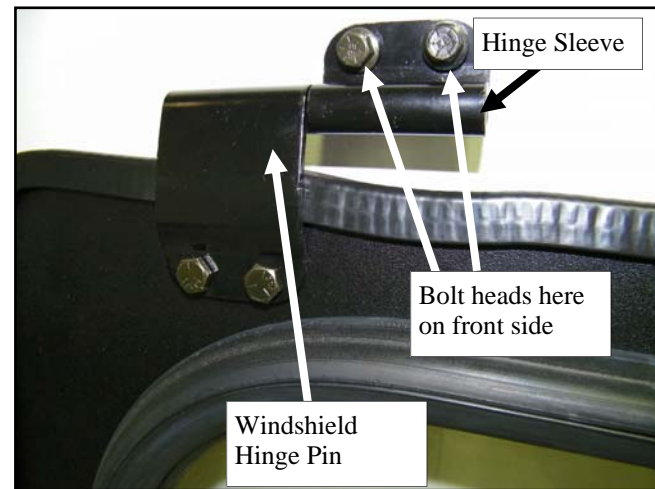

Fig. 4.2 (view of passenger's side)



Fig. 4.5 (view of driver's side)



Fig. 4.2a (view of driver's side)

5. ROOF

Note: If you are planning to install front work lights or 4-way flashers it is easier to pre-install the lights at this time. Please see the instructions in that kit for proper installation steps.

5.1 Before installing roof, use a screwdriver to poke holes through the headliner (11 locations). This will make installation easier. Poke the holes from the headliner side up through the hole in the roof to avoid having the headliner pull away from its glued surface.

5.2 With assistance, put the roof into position on the vehicle. Fasten through the OPS (Operator Protective Structure) on each side at the locations shown in figure 5.2. Fasten using the hardware listed below. **Install finger tight at this time.**

<u>Qty.</u>	<u>Hardware Type</u>
2	5/16-18 x 2-3/4" Flange Bolt
2	5/16 x 1 1/4" OD Steel Fender Washers
2	5/16 x 1 1/4" OD Rubber Fender Washers
2	5/16-18 Nylock Flange Nuts

5.3 Fasten the perimeter of the roof using the hardware listed below.

<u>Qty.</u>	<u>Hardware Type</u>
9	5/16-18 x 3/4" Flange Bolt
9	5/16-18 Nylock Flange Nuts
9	5/16 Nylon Washers

Note: The roof bolts can be tightened at this time, including the long bolts installed in step 5.2.

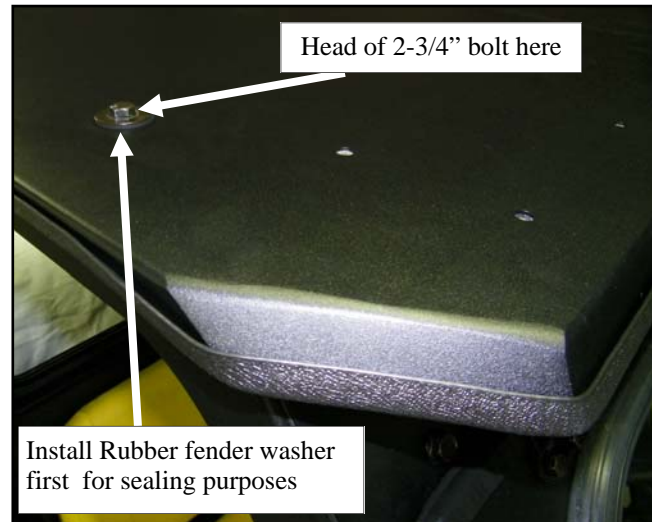

Fig. 5.2 (view of passenger's side front corner)

6. FUEL TANK SHROUD

6.1 Install the fuel tank shroud as shown in figure 6.1. Loosely fasten to the rear panel using the hardware listed below. **Do not tighten at this time. To prevent water and mud entering the cab, angle the rubber filler up onto the rear panel so that it does stick out underneath it.**

Qty. Hardware Type
1 5/16-18 x 3/4" Flange Bolt

6.2 Fasten to the vehicle floorboard using the hardware listed below. **Do not tighten at this time.**

Qty. Hardware Type
2 5/16-18 x 3/4" Flange Bolt
2 5/16-18 Nylock Flange Nuts

6.3 Fasten to the inserts at the back of the front leg using the hardware listed below. Tighten these bolts first and then go back and tighten the bolt installed in step 6.2 and then 6.1.

Qty. Hardware Type
2 5/16-18 x 3/4" Flange Bolt

6.4 The clear fuel cover pivots on the front screw / fender washer set up and swings outward off of the rear bolt for easy fuel tank access.

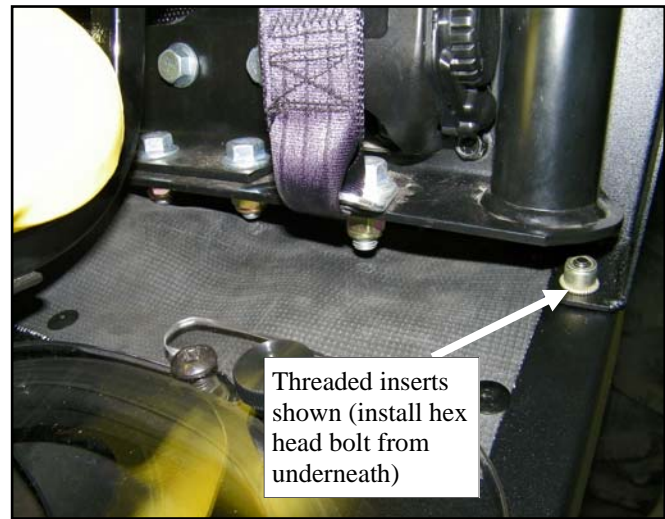

Fig. 6.1 (view of fuel tank shroud)



Fig. 6.2 (view of fuel tank shroud)

7. AIR INTAKE COVER

7.1 Install the air filter cover on passenger's side as shown in figure 7.1. Loosely fasten to the rear panel using the hardware listed below.

Qty. Hardware Type
2 5/16-18 x 3/4" Flange Bolt

7.2 Fasten to the vehicle floorboard using the hardware listed below. **Do not tighten at this time.**

Qty. Hardware Type
2 5/16-18 x 3/4" Flange Bolt
2 5/16-18 Nylock Flange Nuts

7.3 Fasten to the inserts at the back of the front leg using the hardware listed below. Tighten these bolts first and then go back and tighten the bolts installed in step 7.2 and then 7.1.

Qty. Hardware Type
2 5/16-18 x 3/4" Flange Bolt

Note: If there is a filter air pressure indicator installed on the vehicle, remove the large hole plug to allow it to pass through.



Fig. 7.1 (view of air intake cover)

8. DOORS

8.1 Install two ball studs to the OPS (one on each side) as shown in figure 8.1.

Qty.	Hardware Type
2	5/16-18 Ball Studs
2	5/16-18 Nylock Flange Nuts
2	5/16 SAE Steel Washers

8.2 Prior to installing the doors, apply grease to the door hinge pins on the rear panel.

8.3 Install the four brass washers onto the pins. See fig. 8.3.

8.4 With assistance, install the door onto the hinge pins. If necessary, adjust the latch on the door (front to back) and/or the pin on the front leg (up and down) until a “double click” is achieved. Continue to adjust the engagement as necessary until you get the door to close with “two” clicks which is confirmation that the door is fully closed and secure enough to drive. If the door is not sitting evenly on the vehicle, the hinge bolts can be loosened and re-adjusted.

8.5 Install the gas spring after the door is fully adjusted. Attach the large end to the ball stud installed in figure 8.1. The thin rod end should be attached to the door.
 Note: The large end has a quick detach tab on it allowing the door to be removed without the use of tools.

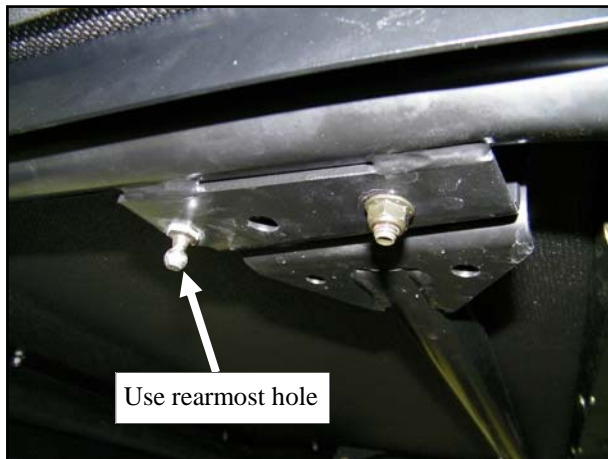

Fig. 8.1 (view of ball stud, passenger’s side)

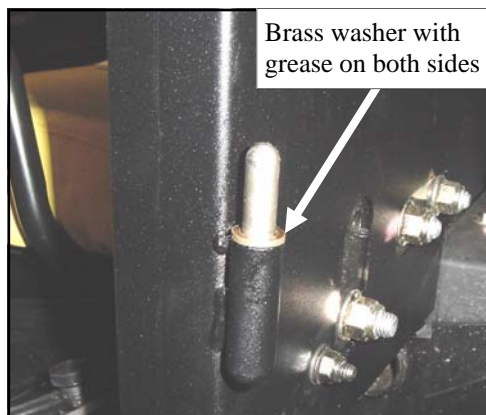

Fig. 8.2 (view of hinge pin)

Troubleshooting the door

Condition:

- Door latch and striker pin does not line up (up and down)
- Door latch and striker pin does not line up (front to back)
- Door is not sitting even on vehicle.

Explanation/Solution

- Move striker pin on front leg up or down.
- Move latch on door forwards or backwards.
- Loosen hinge bolts, realign door, retighten hinge bolts.

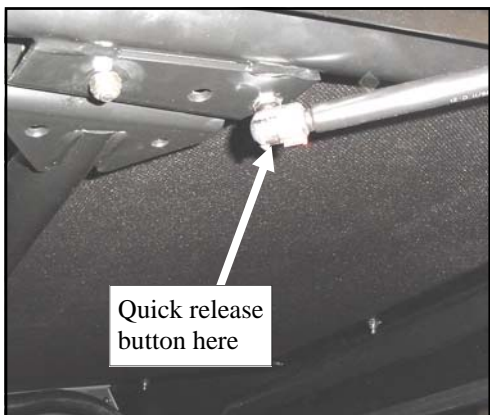

Fig. 8.5 (view of gas spring)



Fig. 8.3 (view of brass washer)

9. CABIN SEALS

9.1 Remove the seat base or flip the seats forward. Clean the area around the two openings that are on either side in the black plastic behind the seat. Be sure that the area is dry and at room temperature and then install the two rectangular foam seals to cover the openings per fig 9.1.

9.2 Vehicles that have the brake lever located between the seats as shown in fig. 9.2 must have a steel/rubber seal installed. Newer vehicles with the brake lever in front of the seat do not require this seal. First slide the seal over the lever and center on the opening. Hold the seal firm against the plastic and install the top sheetmetal screw first. Push the seal against the plastic and install the two center screws followed by the two bottom screws.

Qty. **Hardware Type**

5 #10 x 3/4" Pan Head Sheet Metal Screw

9.3 Install the 11" piece of Expand-a-foam along the edge at the top of the battery compartment under the passenger seat per fig. 9.3. Be sure the area is clean, dry, and at room temperature before adhering the foam.

10. INSTALL WIPER

10.1 Install the wiper per the included installation manual. Be sure to follow the instructions for installing through sheet metal and not glass. The cable ties included can be used to secure the wires. If you are installing a switch panel then you do not need to run a wire for the wiper. A power source is provided on the panel.

11. FINISHING TOUCHES

11.1 Install nut covers on the interior locknuts that are fastened to the (4) 2-3/4" long screws per fig. 11.1. Repeat for opposite side.

12. CARE AND MAINTENANCE

12.1 Check and tighten hardware after 40 hours of operation. Periodically inspect and tighten hardware for the remainder of the unit's life.

12.2 Wash with a mild soap or detergent using your bare hands to free or dislodge any caked-on dirt or other foreign particles.

12.3 Be sure to regularly grease door hinge pins. Also lubricate moving parts in the door latches.

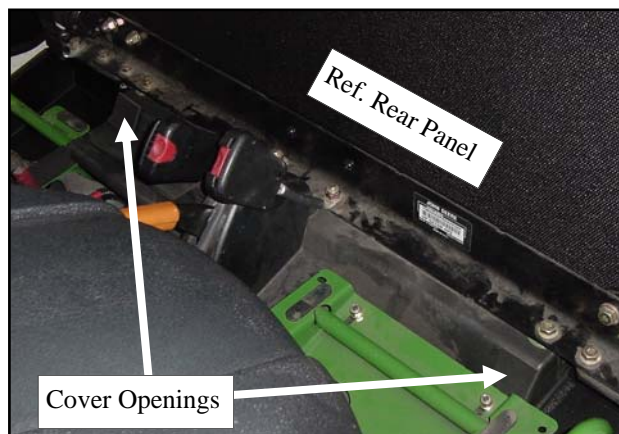

Fig. 9.1 (install seals over openings)

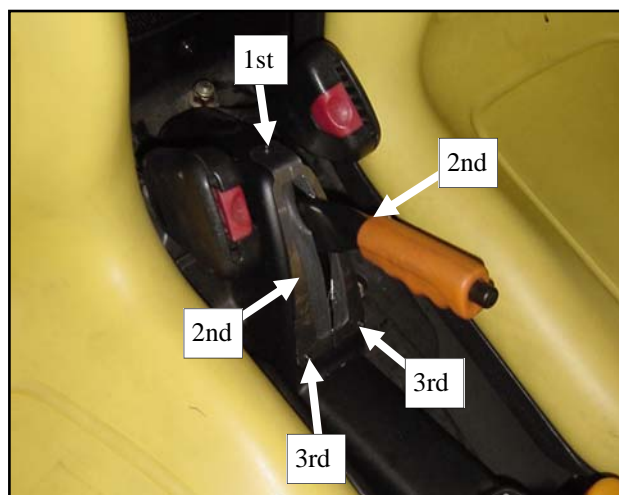

Fig. 9.2 (install brake lever seal)

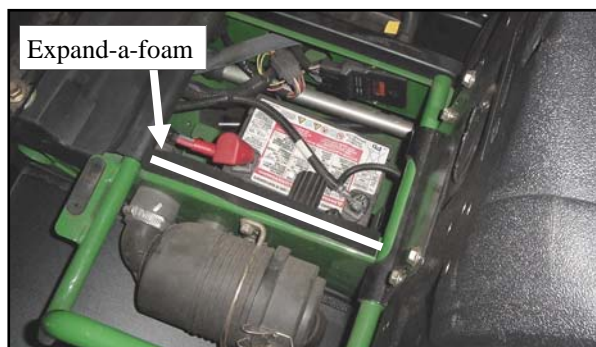

Fig. 9.3 (view under passenger seat)

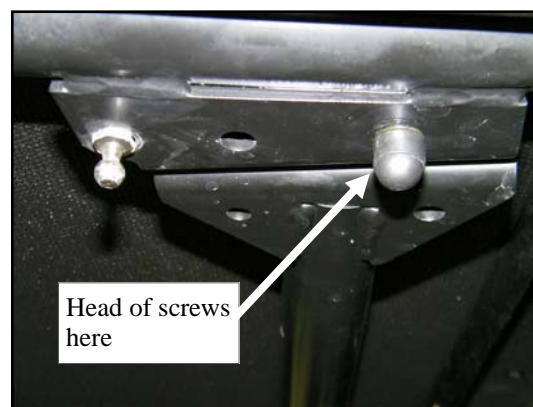
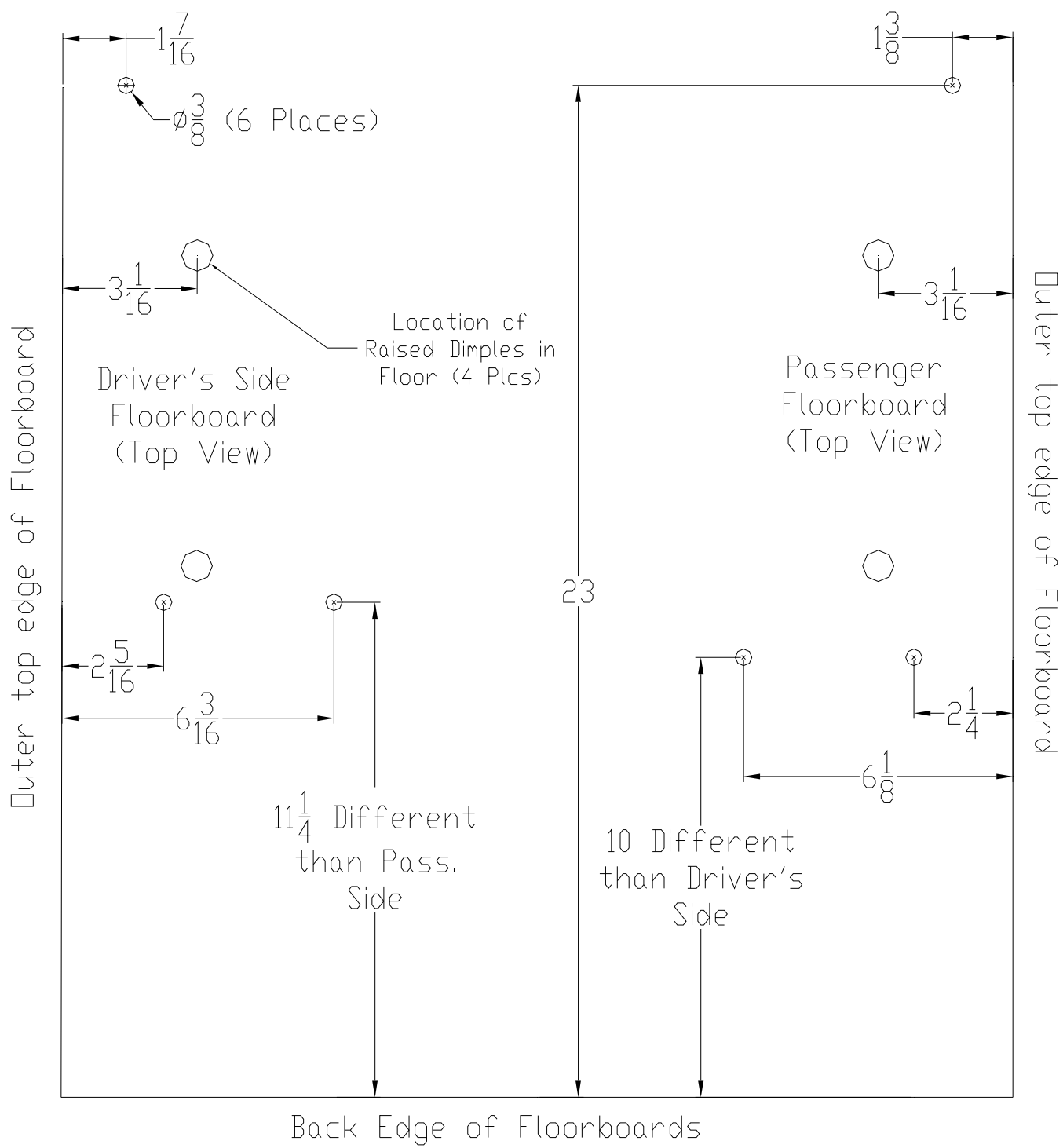
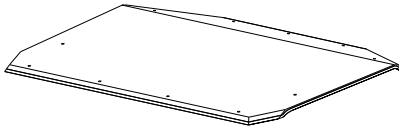

Fig. 11.1 (view of passenger's side)



JOHN DEERE GATOR PATHPRO SE CAB (p/n: 1GTRXUV2)

ROOF	QTY.	P/N
TEXTURED BLACK	1	8SV-GXV201-B4



WINDSHIELD	QTY.	P/N
TEXTURED BLACK	1	8SV-GXV02

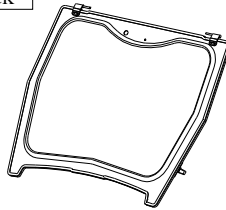

WINDSHIELD SUPPORT	QTY.	P/N
TEXTURED BLACK	1	8SV-GXV203-B4

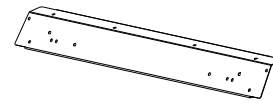

AIR FILTER COVER	QTY.	P/N:
TEXTURED BLACK	1	8SV-GXV210-B4

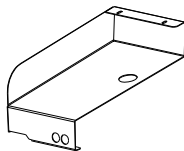

FUEL TANK SHROUD	QTY.	P/N
TEXTURED BLACK	1	8SV-GXV211-B4

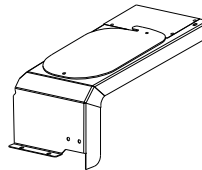

REAR PANEL	QTY.	P/N
TEXTURED BLACK	1	8SV-GXV206-B4

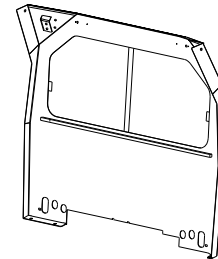

SIDE PANEL	QTY.	P/N
TEXTURED BLACK	1L 1R	8SV-GXV208L-B4 8SV-GXV208R-B4

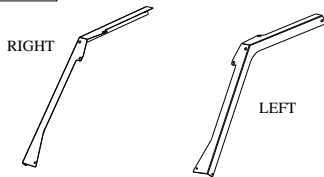

BRAKE LEVER SEAL	QTY.	P/N
TEXTURED BLACK	1	8SV-GXV13-B4



FRONT LEGS	QTY.	P/N
TEXTURED BLACK	1L 1R	8SV-GXV204L-B4 8SV-GXV204R-B4

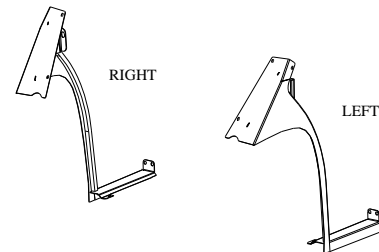

FRONT CLAMP	QTY.	P/N
TEXTURED BLACK	1L 1R	8SV-GXV05L-B4 8SV-GXV05R-B4

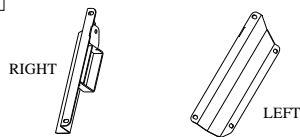

ADDITIONAL SERVICE PARTS

QTY.:	P/N:	DESCRIPTION:
1	8SV-SWGXVRP	REAR PANEL SLIDING WINDOW WITH RUBBER
1	8SV-SWGXDRL	LEFT DOOR SLIDER WITH RUBBER
1	8SV-SWGXDRL	RIGHT DOOR SLIDER WITH RUBBER
1	8SV-PGGXVLDW	LOWER DOOR WINDOW WITH RUBBER
1	GXV1-HWK	HARDWARE KIT (CAB)
1	9SV-GS04Q	GAS SPRING - 14 7/16" LONG QUICK RELEASE (DOOR SET OF 2)
1	9SV-GS02	GAS SPRING - 12 3/8" LONG (WINDSHIELD SET OF 2)
1	9SV-DHRL	OUTSIDE HANDLE ROTARY LATCH KIT
1	9SV-IHRL	INSIDE HANDLE ROTARY LATCH KIT
1	9SV-HSLP	WINDSHIELD HINGE KIT
1	9SV-WL2	WINDSHIELD LATCH KIT 2
1	9PWMI10	WINDSHIELD WIPER MOTOR 110"
1	9PWA14/16	WIPER ARM (14"-16")
1	9PW20-FB	WIPER BLADE 20" - FLEX
1	8SV-PCGXVFTSC	FUEL TANK COVER (POLYCARBONATE)
2	9FR-GXVRF5	RECTANGULAR FOAM SEAL (INSTALLED UNDER SEAT)

HARD SIDED DOORS	QTY.	P/N
TEXTURED BLACK	1L 1R	8SV-GXV27L-B4 8SV-GXV27R-B4

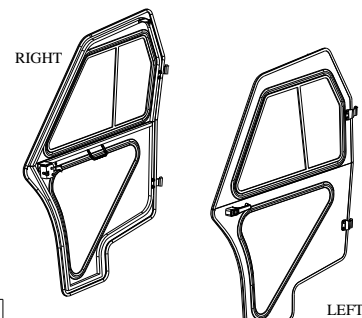

RUBBER TYPES:	3/4" SIDE BULB W/ 1/16" GRIP	5/8" ROUND BULB	1" ROUND BULB	1/2" WEATHER SEAL	TRIM-LOK	1/8" x 1" FOAM TAPE	ARCH PSA	WINDOW RUBBER	BALL CAGE RUBBER
	9SV-PR17-20	9SV-PR02-15	9SV-PR19-10	9SV-PR20-10	9SV-PR01-10	9SV-PR39-5	9SV-PR09-10	9SV-PR10-10	9SV-PR11-10