

KUBOTA B 2320/2620/2920
cab kit p/n 1KB2320
Installation Instructions

The contents of this envelope are the property of the owner.
Be sure to leave with the owner when installation is complete.

APPROXIMATE INSTALLATION TIME: 2 to 3 HOURS
(excluding accessories)





Shown with optional work lights, and optional strobe light.
Additional options available are: heater, hard rear panel, and rear window wiper.
Note: a front windshield wiper comes standard with this cab kit.





CURTIS DESIGN CONCEPT

Curtis cabs feature an assembly of parts designed for your vehicle which require adjustment and alignment of components to accommodate vehicle variations and provide proper weather protection. For accurate installation, proper operation, and years of satisfaction, please read and understand the installation instructions.

From all of us at Curtis, we thank you for choosing our product.

	<h2>NOTICE</h2>
<p>Curtis Cabs, blades and general accessories add additional weight to the base vehicle. All Curtis accessory weights are listed in product brochures. Deduct the accessory's total weight from the vehicle's rated capacity and never exceed the vehicle's rated capacity including driver and passenger.</p>	

	<p>WARNING Exposure to Carbon Monoxide can Cause illness, serious injury or death. Never operate vehicle if suspicious of Carbon Monoxide. Inspect exhaust system for leaks monthly. Leaks can result from loose connections, corrosion, cracks or other damage to the exhaust manifold. If leaks are found, repair or replace exhaust system. Do not use vehicle until repair or replacement is complete.</p>
-----------------------------------------------------------------------------------	-----------------------------------------------------------------------------------------------------------------------------------------------------------------------------------------------------------------------------------------------------------------------------------------------------------------------------------------------------------------------------------------------------------------------

 <h2>WARNING</h2>	
<h3>Serious Injury or Death</h3>	
	<p>This cab enclosure does not provide protection from rollover or other accidents.</p>
	<p>This cab enclosure does not provide protection from flying objects including golf balls.</p>
	<p>This cab enclosure does not provide protection from lightning. When lightning threatens take cover and do not operate vehicle.</p>

CAB INSTALLATION

BEFORE YOU START

HELPFUL HINTS:

- A. Refer to parts diagram toward the back of this manual to help identify parts during the assembly process.
- B. To assist with the cab installation, leave all bolts loose for later adjustment unless otherwise specified.
- C. Read and understand all instructions before beginning.
- D. Plastic washers have been supplied to provide a weather seal under the heads of all exterior bolts. The plastic washer should be installed under each bolt head directly against the outside cab surface. Care should be taken not to over tighten the fasteners and damage the plastic washer. Also use steel washers as required. See diagram.
- E. Apply a silicone sealant to seal any minor gaps that may occur due to vehicle variations.
- F. Use caution to avoid damaging the factory installed threaded inserts. Begin the bolt engagement by hand to avoid or correct potential cross threading.

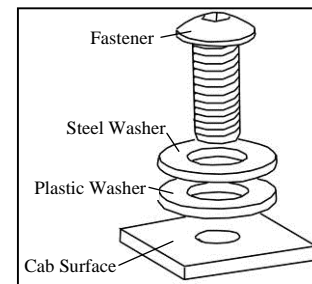

TOOLS REQUIRED

Set of standard and metric sockets
 Set of standard and metric open end wrenches
 Drill
 3/8" drill bit
 Measuring Tape
 Clamp

One Phillips Head Screwdriver
 Scissors
 One 3/8" Drive Ratchet
 One 3/16" Allen Wrench (preferably "T" handle type)

1. VEHICLE PREP

1.1 Per figure 1.1, remove the following items from the vehicle: the optional tool box and clamps from the roll bar (if equipped), and both turn signal lights from the fenders (identify the wires for easier re-connection later). Save the turn signal lights and hardware for re-use.

2. OPTIONAL HARD REAR PANEL

2.1 If not installing a hard rear panel, proceed to step number 3 below.

2.2 Per fig. 2.2, set the hard rear panel assembly in place on the vehicle at this time. Position the rubber seal at the bottom to achieve the best seal against the fender and not interfere with the cup holder.

2.3 Per figure 2.3, attach the (four) roll bar brackets to the optional rear panel with eight 1" long carriage bolts, flat washers, and nuts.

2.4 Skip to Step 4.

3. ROLL BAR BRACKETS & MOUNTS

3.1 Per figure 3.1, attach the vibration mounts to the rear mounts with four 1/4-20 X 1" long button head bolts, flat washers, and lock nuts. NOTE: The vibration mounts should be installed on the side of the rear mount opposite the bent flange.

3.2 Per figure 3.2, loosely attach the rear mounts and roll bar brackets with eight 1" long carriage bolts, flat washers, and nuts. Position the lower set of brackets approximately 10" from the top of the fender to the bottom of the bracket and the upper set 35" from the fender to the bottom of the bracket.

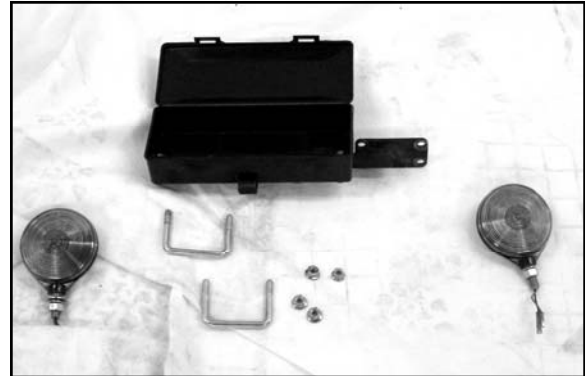

Fig. 1.1 (remove these items from vehicle)



Fig. 2.2



Fig. 2.3

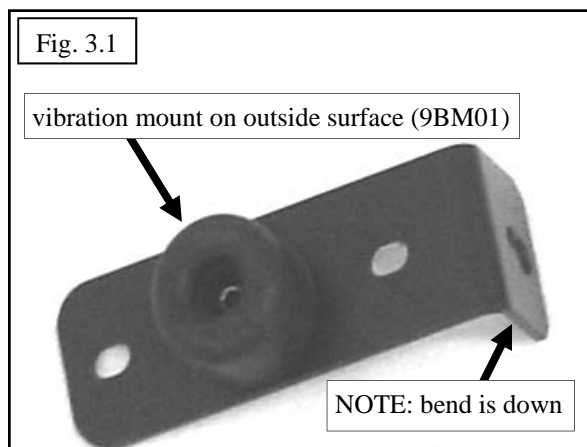

Fig. 3.1

vibration mount on outside surface (9BM01)

NOTE: bend is down

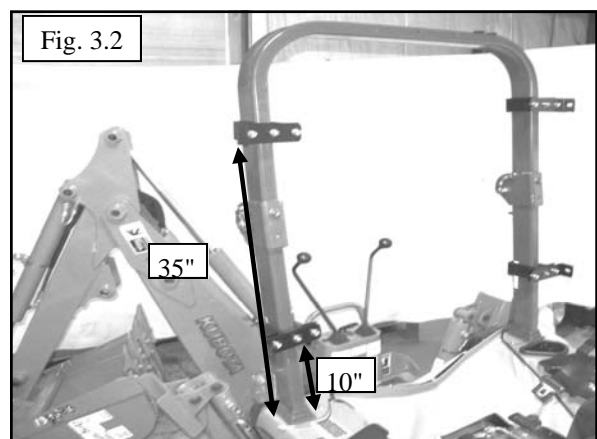

Fig. 3.2

35"

10"

4. COWL

4.1 Per figure 4.1, position the cowl over the hood of the tractor. The seal around the hood area should be positioned to point forward.



Fig. 4.1

5. SIDE FRAME

For ease of installation, remove the doors from side frames by opening and lifting up off of pin hinges.

5.1 With assistance, position the left side frame onto the vehicle. Attach to rear roll bar mounts with 3/4" long button head bolts and flat washers (2 per side). **Note:** if installing with optional hard rear panel, attach to it with 3/4" long button head bolts (4 per side, extra hardware included with rear panel.) Reference figure 5.1

5.2 Repeat for right side frame.

5.3 Per fig. 5.3, Position the cowl so that the angled flange on the bottom is between the side frame and the rubber mat of the tractor and attach to side frame with 3/4" long button head bolts, 4 per side. The top bolt uses a nut and flat washer. The remaining bolts go into the threaded inserts of the frame and use a nylon washer. Reference helpful hints. Line up the sides of the cowl with the outside surface of the side frames, use a clamp to pull in the top of the cowl and tighten the hardware at this time.



Fig. 5.1

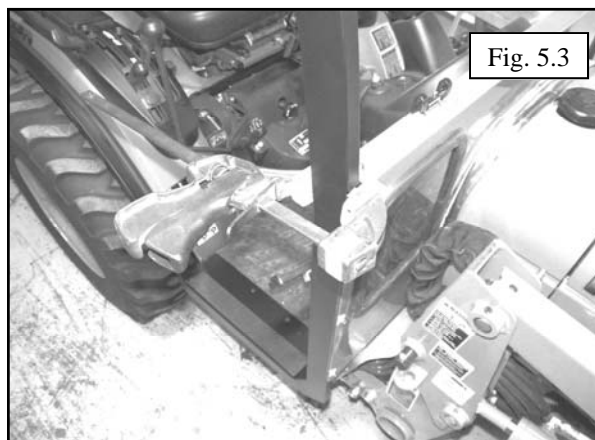

Fig. 5.3

6. WINDSHIELD SUPPORT

6.1 See fig. 6.1. With assistance, install the windshield support to the top front corner of the side frames oriented as shown with the 90 degree bent flanges on the bottom. In the lower holes only, use the following hardware per side frame: one 5/16-18 x 3/4" long button head bolt, 2 steel washers, one nylon washer, and one locknut. Refer to the helpful hints section on page two for the proper placement of the nylon washer. Note: upper holes will get hardware once the roof is installed.

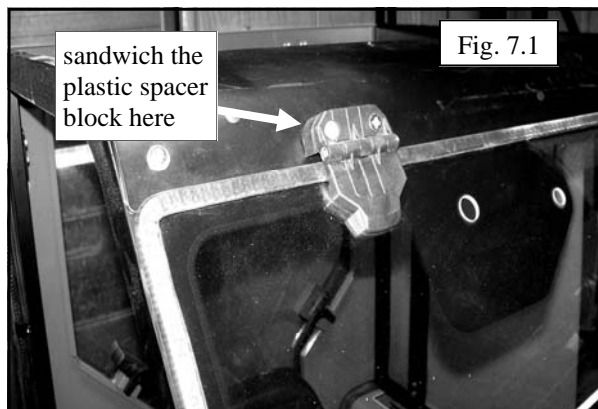

Fig. 6.1

7. WINDSHIELD

7.1 See fig. 7.1. Have the following items ready: four 5/16-18 x 1 3/4" long flat head bolts, 4 steel washers, 4 locknuts, and 2 plastic spacer blocks. With assistance, install the windshield hinges to the windshield support with the two spacer blocks between the hinge and the windshield support. Attach windshield latches to windshield latch receivers on the cowl by squeezing tabs to retract spring loaded pins. See fig. 7.1.1. Lift up on bottom of windshield and close latches. Check alignment of windshield with side frames and tighten hinge hardware.

CAUTION: hinges are plastic components. Do not overtighten hardware. Torque to 7 foot-pounds max.. Also tighten windshield support bolts (from Step 6).



8. ROOF

8.1 Use a Phillips head screwdriver to punch a hole through the headliner at any of the covered bolt hole locations. Punch holes from the inside out to avoid having the headliner pull away from its glued surface.

8.2 Install the roof oriented so the reflectors are towards the rear of the vehicle. Use the following hardware in the front corners: one 5/16-18 x 1" long button head bolt, two steel washers, one nylon washer, and one locknut (locknuts on the inside surface). Install the bolt through the roof, windshield support, and mounting tab. See the helpful hints section on page two for placement of nylon washers. See figure 8.2

8.3 The middle and rear bolt location on both the left and right sides uses the following hardware per side: two 5/16-18 x 3/4" long button head bolts, two steel washers, and two nylon washers. These two bolts are installed into factory installed threaded inserts in the top of each side frame. **NOTE:** use caution to avoid damaging the internal threads on the factory installed threaded inserts.

8.4 The remaining two holes each use the following hardware: 5/16-18 x 3/4" long button head bolt, 2 steel washers, 1 nylon washers, and 1 locknut. Locknuts to be on the inside surface.

8.5 Make sure the slots in the side frame are centered on the 2 front corner bolts and tighten them at this time. Tighten remaining roof bolts.

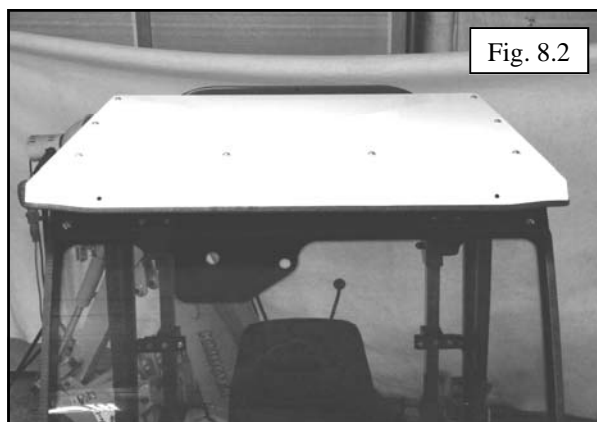
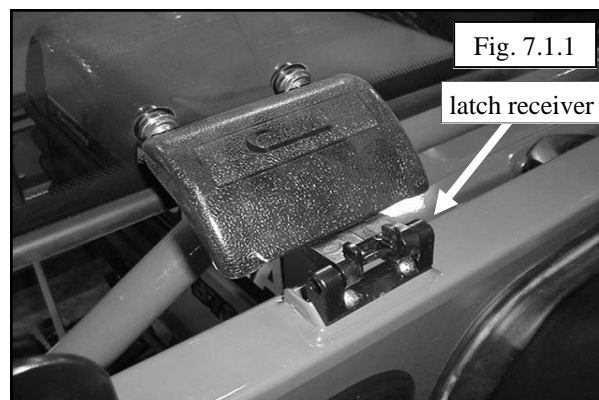

9. REAR CURTAIN.

9.1 Tighten roll bar brackets and mounts. NOTE: It may be necessary to have an assistant lift up on the back of the side frames before tightening the roll bar brackets and mounts as the weight of the cab tends to make it sag towards the back.

9.2 Put nut covers on roll bar bracket nuts.

9.3 See fig. 9.3. and 9.3.1 Make sure the inside rear frame tubes are clean and dry and at room temperature. Apply the supplied self-adhesive Velcro along the inside face of the tube along the back edge. Note: apply Velcro directly over roll bar bracket mounts.

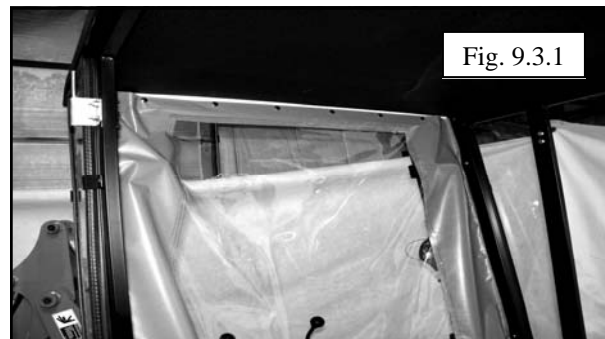
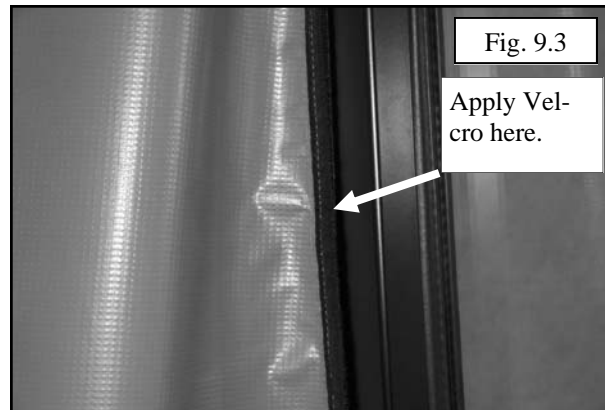

10. UNDER SEAT FILLER

10.1 Fig. 10.1 and 10.1.1 shows the under seat filler. Begin by snapping into place along optional hard rear panel or Velcro to bottom of rear curtain. Next do a dry fit to get a feel for where the filler fits and seals best. Example: slots are for seat belts to pass through, etc..

10.2 Make sure the areas where the supplied self-adhesive hook velcro will be applied are clean and dry and at room temperature for best adhesion. Apply the corresponding velcro where deemed necessary and to match velcro of vinyl filler. See figures 10.2 and 10.2.1



11. FINISHING TOUCHES

11.1 See Figure 11.1 Use the holes in the side frame floorboards as a guide to drill holes through the tractor floor. **WARNING: Check underneath for obstructions before drilling. Be sure not to drill through hoses or hydraulic lines.** Attach frames to floor with 1" long button head bolts (2 per side). Tighten bolts.

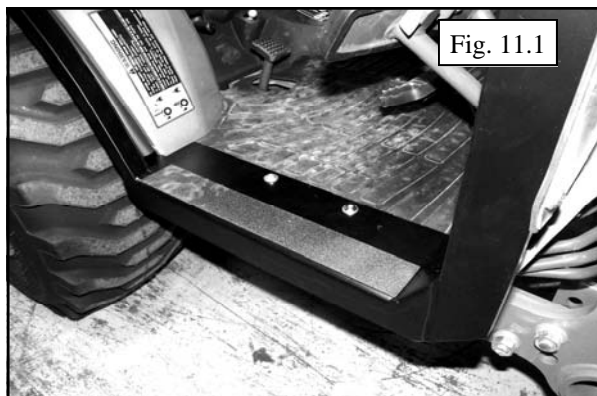

Fig. 11.1

11.2 See fig. 11.2. Mount the turn signal lights to the brackets on the side frames and reconnect the wires using the extension wires provided in the kit. **NOTE:** Just run the wires under the rear curtain or rubber seal at the bottom of the optional rear panel and through the hole in the fender where the lights were originally mounted.

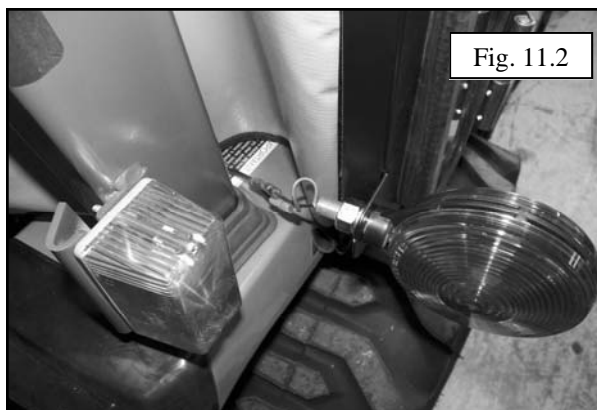

Fig. 11.2

11.3 Install nut covers on all remaining nuts on the inside of the cab.

11.4 Apply grease to the pin hinges. With assistance, re-install the doors onto the pin hinges. Work the doors back and forth until the hinges are completely seated. Install the supplied cable door stops between the bracket on the door and the bracket on the side frame, see figure 11.4. Tighten hardware to engage the nylon lock nuts but loose enough to allow the cable ends to pivot.

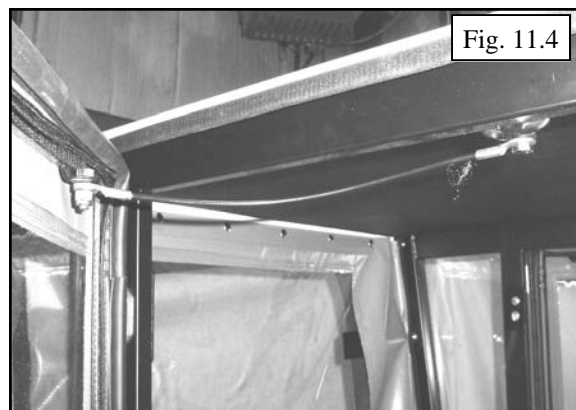

Fig. 11.4

11.5 Peel protective film from windows

12. DOOR ADJUSTMENT

12.1 If necessary specific adjustments can be made per steps 12.2 and 12.3. **Note:** Top of door should end up visually parallel with side of roof. **Note:** The door latch is a rotary type with two positions to close. Adjust door so that when fully closed door latch clicks **twice** for total engagement.

12.2 Per fig. 12.2, the large striker bolt and nut can be loosened and reset higher or lower, in or out for better engagement and door seal. Use two 19mm open end wrenches. **Note:** finger guard to end up being centered and facing inward.

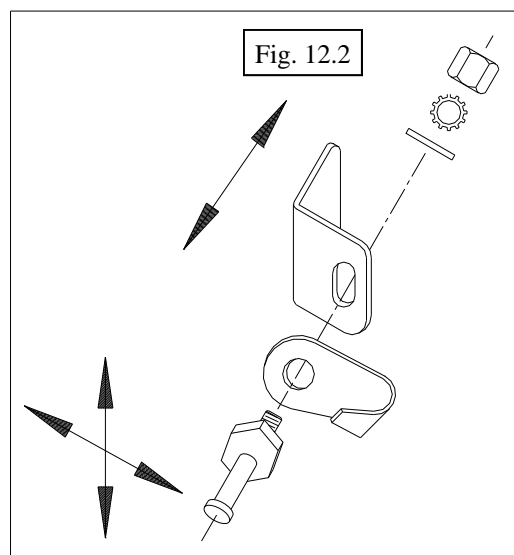

Fig. 12.2

12. DOOR ADJUSTMENT (Continued)

12.3 Per fig. 12.3, the 1/4-20 hex head bolts on the door hinges can be loosened on the rear tube, or on the door itself, or in both places, in order to rotate or move the door up or down and forward or backward as necessary for proper alignment with side frame. Note: An assistant will be needed for this step. Keep the hinge sleeves fully seated on the pin hinges. Tighten all hinge bolts using caution to **not** over tighten. Over tightening will crush (damage) the structural tubing. **Torque to 40 inch/pounds.**

12.4 Reference figure 12.4 The inside latch can be moved forward or back for proper engagement with the striker bolt engagement.

CAUTION: FOR SAFE OPERATION, DO NOT DRIVE WITH DOORS OPEN. MAKE SURE DOORS ARE CLOSED AND PROPERLY LATCHED WHEN DRIVING.

13. CARE AND MAINTENANCE

13.1 Once the doors are properly adjusted, lubrication (preferably grease) can be applied to the striker bolts and door latch assemblies. Re-apply periodically as needed (same goes for the door pin hinges as necessary).

13.2 Check and tighten hardware after 40 hours of operation. Periodically inspect and tighten hardware for the remainder of the unit's life.

13.3 Wash the painted surfaces of the unit with commercial automotive cleaning products.

13.4 Clean windows with glass cleaner.

13.5 Vinyl components should be washed with a mild solution of warm soapy water.

13.6 Clear vinyl can be easily scratched. Be careful cleaning frost or snow from rear curtain. Do not roll curtain in cold weather. The curtain becomes stiff and may crack. Keep curtain clean.

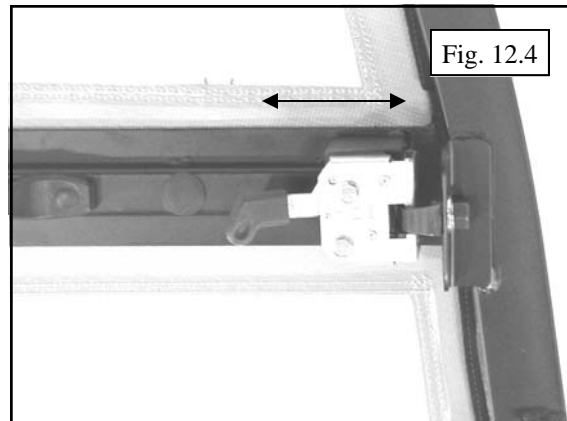
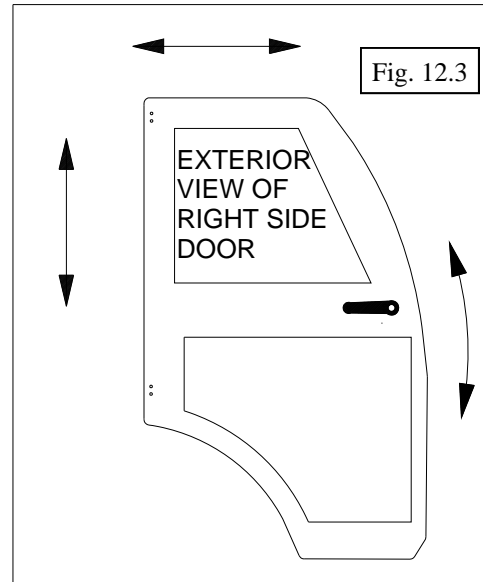

KUBOTA B 2320/2620/2920 SOFT SIDED CAB PARTS LIST

ROOF QTY. P/N
1 KB23-01

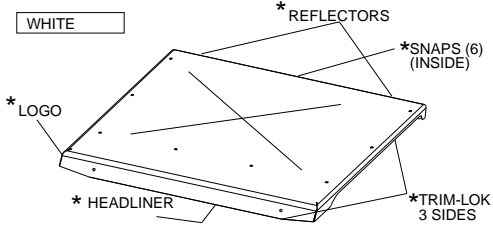

WINDSHIELD QTY. P/N
1 1KU3-02

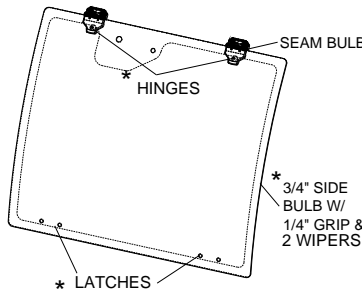

ROLL BAR BRACKET MNT QTY. P/N
4 KB23-05

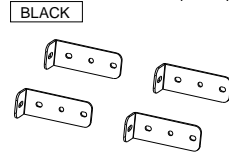

RUBBER TYPES:

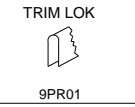
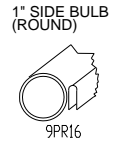
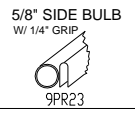

WINDSHIELD SUPPORT QTY. P/N
1 KB20-03

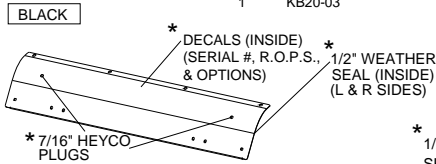

COWL QTY. P/N
1 KB23-04

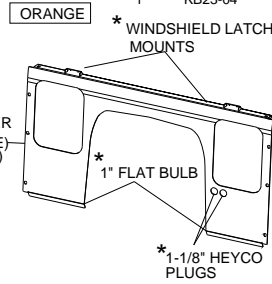

ROLL BAR BRACKET QTY. P/N
4 KB23-12

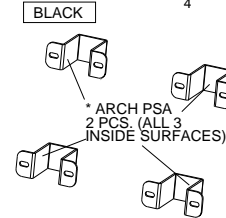

SIDE FRAMES QTY. P/N
LEFT 1 KB23-09L
RIGHT 1 KB23-09R

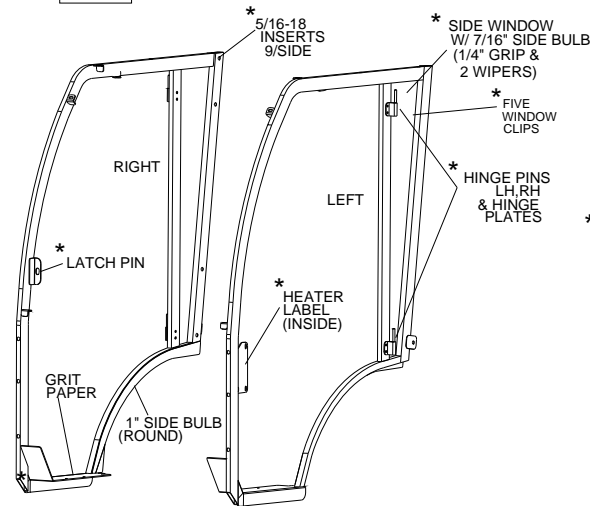

SOFT DOORS QTY. P/N
BLACK (WITH ORANGE VINYL)
LEFT 1 KB23-07L
RIGHT 1 KB23-07R

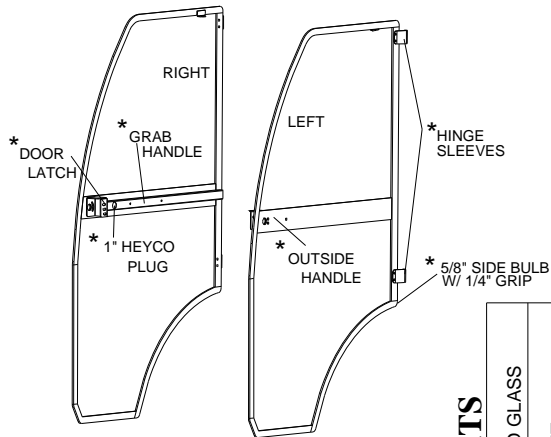

REAR CURTAIN QTY. P/N
1 KB23-08

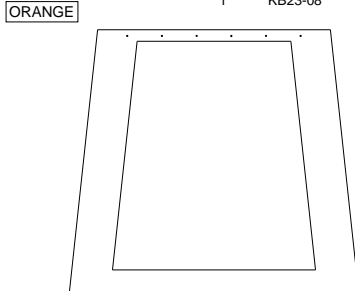

UNDER SEAT FILLER QTY. P/N
1 KB23-10

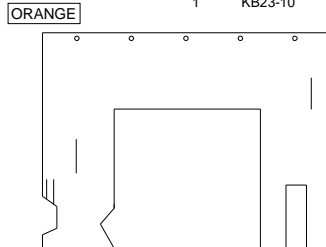

ADDITIONAL SERVICE PARTS

QTY./UNIT	P/N	DESCRIPTION
1	9GL-33X39	MOLDED WINDSHIELD GLASS
1	KB23-HWK	HARDWARE KIT
1	9DS02	CABLE DOOR STOP KIT
1	9PH008	UNITIZED FRAME HINGE KIT
1	KB23-011L	LEFT DOOR SKIN
1	KB23-011R	RIGHT DOOR SKIN
1	9DL01A	ROTARY DOOR LATCH - LH
1	9DL01B	ROTARY DOOR LATCH - RH
1	9DL01C	OUTSIDE R-LATCH HANDLE W/ KEY
1	9WL01	WINDSHIELD LATCH KIT
1	9PH007 & 9BLK01	WINDSHIELD HINGE KIT

*IN HOUSE APPLICATIONS

CABS/BLADES/SPREADERS/ACCESSORIES