



INSTALLATION MANUAL ACRYLIC WINDSHIELD

(clear p/n's: 77700-V5027, V5027) (tinted p/n's: 77700-V5028, V5028)
KUBOTA RTV-X900, RTV-X1120D, RTV-X1140, RTV-XG850

CALIFORNIA PROPOSITION 65



Cancer and reproductive harm - www.P65Warnings.ca.gov

COMPATIBLE WITH:

1. VC5000 Metal Canopy (Black)
2. VC5001 Metal Canopy (Orange)
3. VC5011 Plastic Canopy (Black)
4. VC5043 Plastic Canopy (Black)
5. VC5044 Metal Canopy (Black)

NOT COMPATIBLE WITH:

V5221 canopy, doors, wiper, switch panel/wire harness - multiple accessory, or heater.

BEFORE INSTALLING WINDSHIELD

- Read all instructions and safety instructions in this manual.
- Refer to your machine's operator's manual and safety instructions on your machine's safety decals.
- Wear appropriate personal protective equipment (PPE) when performing work.
- Hang a "DO NOT OPERATE" tag in operator station.



WARNING

To avoid personal injury or death:

- This windshield does not provide protection from: a rollover (or other accidents), from flying objects (including golf balls), or from lightning. When lightning threatens, take cover and do not operate vehicle.

NOTICE

- **NEVER USE** an alcohol-based product for cleaning. Many brand-name glass cleaners contain alcohol that will result in deterioration of the windshield.
- Wash with a mild soap or detergent using your bare hands to free or dislodge any caked-on dirt or other foreign particles.
- A soft, grit-free cloth, sponge, or chamois may be used but only as a means of carrying water to the windshield.
- An appropriate plastic cleaner can be used to remove light scratches.

Estimated assembly time: 30 minutes

■ CONTENTS OF HARDWARE KIT 77700-05139

Ref.	Part No.	Part Name	QTY	REMARKS
A	-	Screw, Hex Flange, 1/4-20 x 1-1/2" long	4	NSS
B	-	Fender Washer, Steel, 1/4" I.D. x 1" O.D.	4	NSS
C	See replacement p/n below	Rubber Grommet, Custom, RTV Acrylic Windshield	4	For qty.: one, see p/n below
D	See replacement p/n below	P-Clamp, 2" (black vinyl dipped)	4	For qty.: one, see p/n below
E	-	SAE Steel Washer, 1/4"	4	NSS
F	-	Nylock Nut, 1/4-20	4	NSS

NSS: Not sold separately

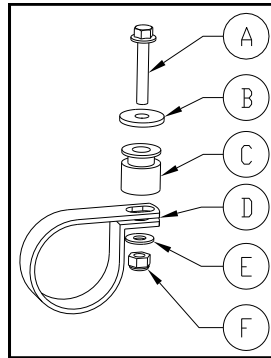

■ AVAILABLE REPLACEMENT PARTS

Ref. No.	Part No.	Part Name	QTY	REMARKS
1	77700-05138	Impact Modified Acrylic Windshield (clear)	1	Code No.: PC-KX9WS (contains one windshield)
2	77700-05140	Impact Modified Acrylic Windshield (tinted)	1	Code No.: PC-KX9WST (contains one windshield)
3	77700-05139	Hardware Kit	1	Code No.: KX900HWK-04 (contains 4 ea. of A thru F)
4	70000-01227	P-Clamp (black vinyl dipped)	1	Code No.: V4268/9A (contains one P-Clamp)
5	70000-01228	Custom Rubber Grommet	1	Code No.: V4268/9B (contains one Grommet)

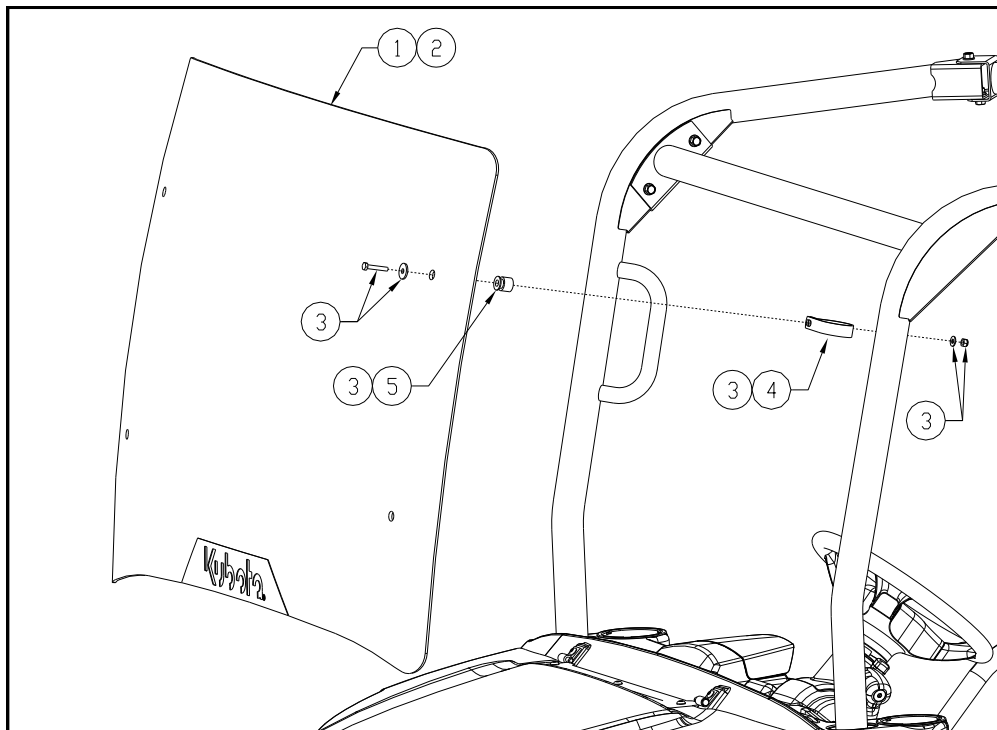

■ MACHINE PREPARATION



CAUTION

To avoid personal injury:

- Park the machine on a firm and level surface.
- Apply the parking brake if applicable.
- Stop the engine and remove the key from the machine if applicable.

■ ASSEMBLY PROCEDURE

NOTE:

- **All assembly procedures listed within this manual are generally representative of the machine model for which the manual is written.** Your machine may be configured differently, but the outline for the procedure should still be followed. For further support for any issues not covered within the pages of this manual, please contact your local Kubota representative.

1. Refer to both illustrations on previous page.
2. Install the black rubber grommets into the 4 holes in the windshield oriented so that the body of the grommet is towards the inside.
3. Install P-Clamps on the front ROPS tube with flats forward as shown. Two on each post.
4. Hold the windshield in place on the vehicle and fasten through each grommet with a bolt and fender washer from the front and secure with a small washer and nut on the inside of the P-Clamp.
5. Leave a gap below the windshield and tighten bolts until the rubber grommet bulges slightly. **Do not over-tighten or the windshield will crack.**