



**Massey Ferguson GC1723 Series**  
**Cab p/n: 1MFGC1723PR**  
**Fits Tractor Models: GC1723E, GC1723EB,**  
**GC1725M and GC1725MB**

*While this cab kit was designed to fit on the vehicle(s) listed above, manufacturing tolerances and vehicle assembly may affect cab fitment. It is the responsibility of the cab installer to check all vehicle pedals and levers for full functionality and, as required, adjust the cab fitment to prevent any interference of the cab components with the travel of pedals or levers.*



**Available Options:**

1. Front LED Work Lights (P/N: 9LEDW4)
2. Rear LED Work Lights (P/N: 9LEDW3)
3. Strobe Light (P/N: 9LEDS2)
4. Dome Light (P/N 9LEDD14)
5. Heater (P/N: 9PH20S54)
6. Switch Panel (P/N: 9PSF1)
7. Side View Mirrors (P/N: 9PM5)
8. Rear View Mirror (P/N: 9PM3)
9. Rear Wiper (P/N: 9PWK85F)

Note: Front wiper (P/N: 9PWK110) is included with the cab kit.

Approximate Installation Time *
Experienced Dealer Technician – 3 Hours
Average Dealer Technician – 4 Hours
Do-It-Yourself – 5 Hours

(\*=Not including accessories)

Approximate Product Specifications
Floorboard to Roof Height: 59-1/4 inches
Weight: 285 lbs.
Cab Width: 44-1/2 inches

The contents of this envelope are the property of the owner. Leave with the owner when installation is complete.

# TABLE OF CONTENTS

WARNINGS, TIPS, & REQUIRED TOOLS.....	3
CAB INSTALLATION.....	4-15
CAB FEATURES & OPERATION.....	16-17
CARE AND MAINTENANCE.....	17
SERVICE PARTS .....	18-19
OPTIONAL ACCESSORIES .....	20
BOLT TORQUE SPECIFICATIONS .....	21-22

## WARNINGS, TIPS, & REQUIRED TOOLS

*Curtis cabs feature an assembly of parts designed for your vehicle which require adjustment and alignment of components to accommodate vehicle variations and provide proper weather protection. For accurate installation, proper operation, and years of satisfaction, please read and understand the installation and owner's manual fully prior to installing the cab.*

*From all of us at Curtis, we thank you for choosing our product.*



### NOTICE

**Curtis Cabs, blades and general accessories add additional weight to the base vehicle. All Curtis accessory weights are listed in product brochures. Deduct the accessory's total weight from the vehicle's rated capacity and never exceed the vehicle's rated capacity including driver and passenger.**

**▲ WARNING** *Exposure to Carbon Monoxide can Cause illness, serious injury or death. Never operate vehicle if suspicious of Carbon Monoxide. Inspect exhaust system for leaks monthly. Leaks can result from loose connections, corrosion, cracks or other damage to the exhaust manifold. If leaks are found, repair or replace exhaust system. Do not use vehicle until repair or replacement is complete.*

**California Health and Safety Proposition 65 Warning:** This product may contain chemicals known to the state of California to cause cancer and birth defects or other reproductive harm.

## GENERAL INFORMATION BEFORE YOU START

### HELPFUL HINTS:

- Refer to parts diagram found in the service parts section of this manual to help identify parts during the assembly process.
- To assist with the cab installation, leave all fasteners loose for later adjustment unless otherwise specified.
- Read and understand all instructions before beginning.
- Apply a silicone sealant to seal any minor gaps that may occur due to vehicle variations.
- Use caution to avoid damaging the factory installed threaded inserts or weld nuts. Begin the thread engagement by hand to avoid or correct potential cross threading.
- Make sure the areas where the supplied self-adhesive hook Velcro will be applied are clean and dry and at room temperature for best adhesion.
- Before installing parts with factory installed rubber, make sure the rubber is fully installed onto the parts for proper fit and sealing.

### TOOLS REQUIRED:

- |   |                               |
|---|-------------------------------|
| • Set of Standard and Metric Sockets (3/8" Drive) | • Drill/Driver                |
| • 3/8" Drive Ratchet and Long Drive Extension     | • 3/8" Drill Bit              |
| • Set of Standard and Metric Open-End Wrenches    | • #2 and #3 Phillips Head Bit |
| • Set of Standard and Metric Allen Wrenches       | • Grease                      |
| • #2 and #3 Phillips Head Screwdrivers            | • Silicone Sealant            |
| • Torque Wrench                                   | • Touch-up Paint              |

# CAB INSTALLATION

## STEP 1: (VEHICLE PREP)

- 1.1 Remove SMV (Slow Moving Vehicle) sign. Save for reuse.
- 1.2 (GC1723EB & GC1725MB only). Remove the bolted-on SMV bracket. Save for reuse.
- 1.3 Remove (2) Rear signal lights. Save the lights and bolts for reuse. Disconnect wires under fender and pull out of the ROPS tube (Roll-Over Protective Structure). Save the M8 screws for reuse.
- 1.4 Remove (2) Plastic pine tree clips from each side of the floor mat. See Fig. 1.4a and 1.4b. Discard clips.

**NOTE:** The remainder of the pine tree clips can be removed at this time to aid in installation of the seal kit. Retain these clips for reuse.

- 1.5 Remove (1) Floor pan mounting screw (M8) from each side of the vehicle. See Fig. 1.5a and 1.5b. Discard screws.
- 1.6 Drill through the forward holes in each side of the floorboard where the pine tree clips were removed, with a 3/8" drill bit.

**WARNING:** To avoid damaging the hydraulic lines underneath, use a drill stop or place a piece of scrap wood under the floorboard on the right side of the tractor.

**NOTE:** Push the reverse pedal down to gain access to drill the hole on the right side of the cab.

- 1.7 Paint the edges of the drilled holes to prevent corrosion.

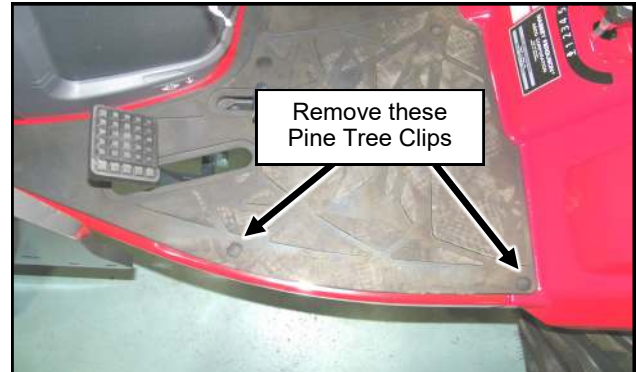

Fig. 1.4a (Pine Tree Clips, Left Side)



Fig. 1.4b (Pine Tree Clips, Right Side)

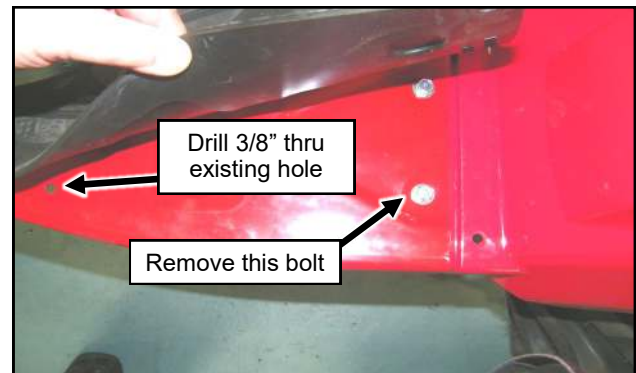

Fig. 1.5a (Floorboard Bolt, left Side)

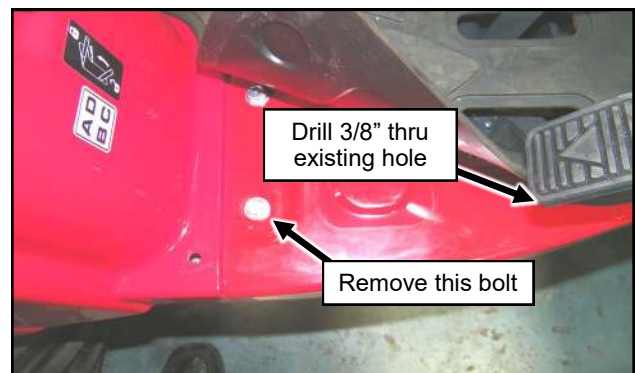

Fig. 1.5b (Floorboard Bolt, Right Side)

# CAB INSTALLATION

## STEP 1: (VEHICLE PREP, CONT'D)

- 1.8 (FL1805 Loader Only) Bend the handles on the Clevis pins for the loader outward as shown, to allow the pins to rotate out from behind the side frames. See Fig. 1.8.

**NOTE:** The notch for the loader clevis pin that prevents the pin from rotating causes the pin handle to be behind the cab side frame. Bending the pin handle allows the pin to rotate so the loader can be removed.

- 1.9 Per Figure 1.9, loosen the bolt holding the accelerator pedal to the lever.

Rotate the top of the pedal towards the rear of the tractor and slide the pedal towards the rear so that the bolt is in the front of the slot, then tighten the pedal bolt.

- 1.10 Per Figure 1.10, cut or grind the end of the Accelerator lever flush with the front edge of the bracket on the Accelerator pedal.

**NOTE:** GC1725M Accelerator pedal shown in Figures 1.9 and 1.10. Adjustment procedure is identical for GC1723E.

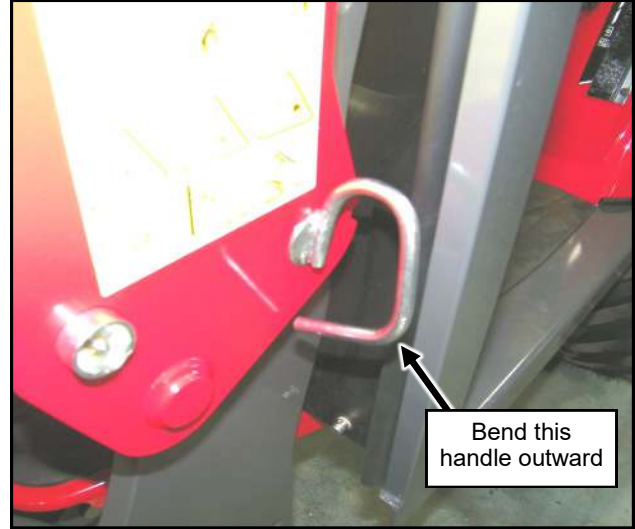

Fig. 1.8 (Loader Clevis Pin Handle)

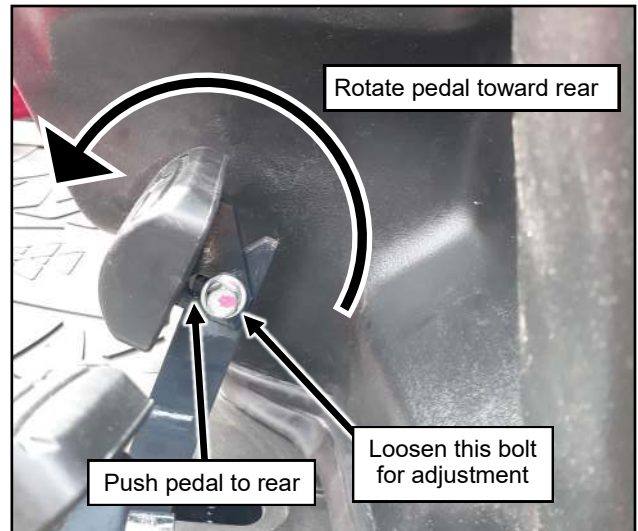

Fig. 1.9 (Adjust Accelerator Pedal)

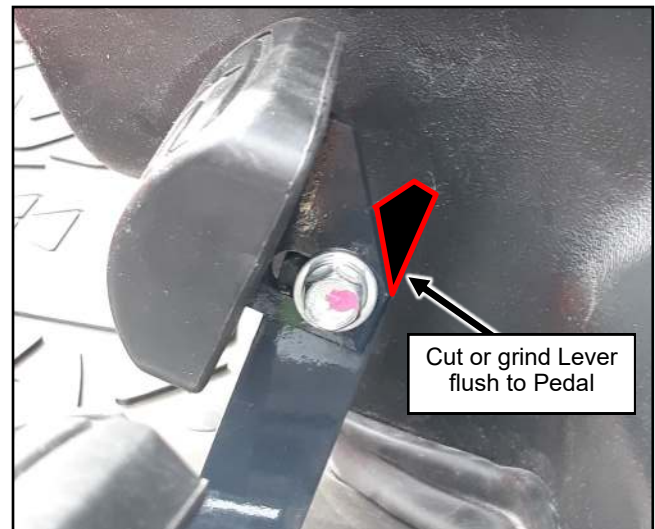

Fig. 1.10 (Trim Accelerator Pedal Lever)

# CAB INSTALLATION

## STEP 2: (FLOORBOARD BRUSHES)

**NOTE:** For best adhesion, apply the flex brushes to a clean, dry surface at room temperature.

- 2.1 Remove the Pine Tree Clips holding the floor mat to allow access to the top of the tractor floorboard.

**NOTE:** Full removal of the floor mat is not necessary and might be hindered by the hydraulic lines for the front end loader. The floor mat can be removed entirely by disconnecting the hydraulic lines at the quick couplers.

- 2.2 Per fig. 2.2, remove the protective film from the pressure sensitive adhesive and adhere the two 8" long brushes (5/8" long bristles) to either side of the Brake Pedal, oriented as shown.

Adhere two of the four 5" long brushes (5/8" long bristles) to either side of the Differential Lock Lever.

- 2.3 Per fig. 2.3, adhere two 5" long brushes (5/8" long bristles) beside the Forward and Reverse pedals, between the two pedals, oriented as shown.

Adhere the remaining two 5" long brushes (1" long bristles) beside the Forward and Reverse pedals, to the outside of the two pedals, oriented as shown.

- 2.4 Re-install the floor mat. Leave the outer two Pine Tree Clips out from each side of the floor mat for cab installation.

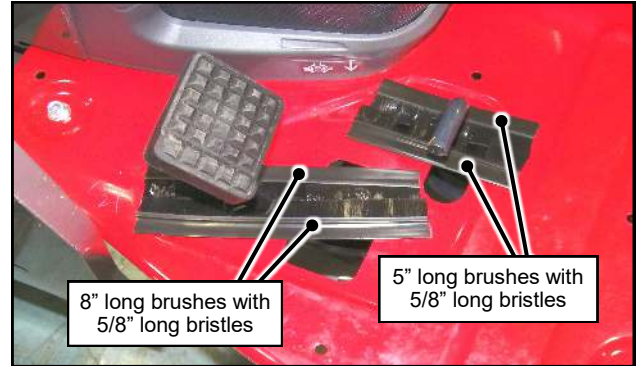

Fig. 2.2 (Left Floorboard Brushes)

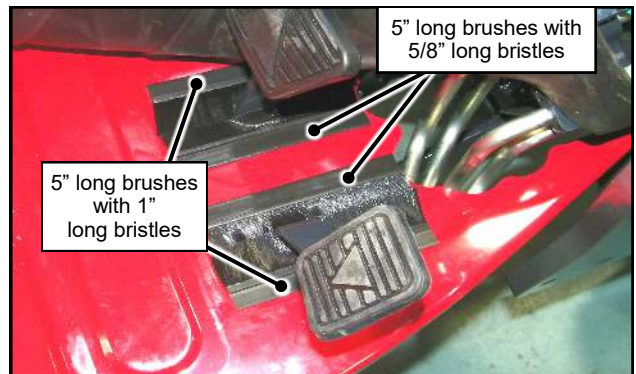

Fig. 2.3 (Right Floorboard Brushes)

## STEP 3: (LEFT SIDE FENDER BRUSHES)

- 3.1 Per fig. 3.1, adhere the 18" long brush (1" long bristles) to the outer side of the PTO levers, aligned to the label on the opposite side of the levers. Install one of the two 10" long brushes (1" long bristles) to the outer side of the PTO lever, aligned to the label on the opposite side of the lever.

- 3.2 Per fig. 3.1, install a self-drilling screw at each end of both sealing brushes into the tractor fender. Place the screws centered on the plastic brush holder, 1/4" to 1/2" from the end of the brush.

**CAUTION:** Operate the driver as slowly as possible while installing the self-drilling screws into the plastic, to avoid damage to the brush or fender.

### Hardware Used

#10 x 1/2" Self-Drilling Pan Head Screws

### Qty

4

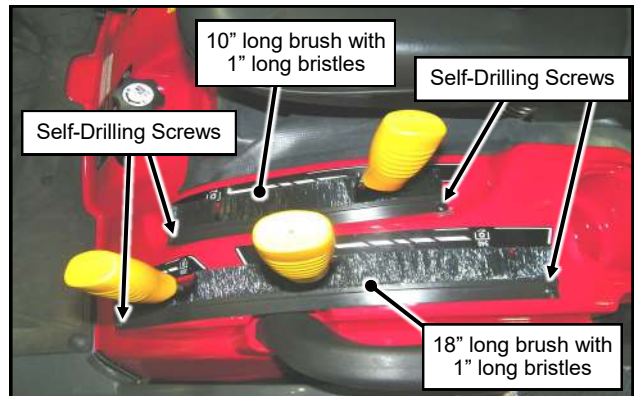

Fig. 3.1 (Attach Brushes to Left Fender)

## STEP 4: (RIGHT SIDE FENDER BRUSHES)

- 4.1 Carefully remove the label for the gear speed lever shown in fig. 4.1 and adhere it to the 14" long brush (1" long bristles), oriented as shown in fig. 4.2 on the next page.

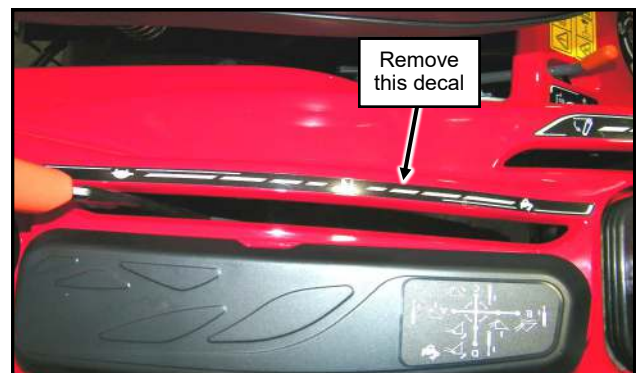

Fig. 4.1 (Remove and Reuse Decal)

# CAB INSTALLATION

## STEP 4: (RIGHT SIDE FENDER BRUSHES) (Continued)

- 4.2 Per fig. 4.2, adhere the 14" long brush (1" long bristles) to the inner side of the gear speed lever, with the front of the brush aligned to the edge of the fender.
- 4.3 Per fig. 4.2, adhere the remaining 10" long brush (1" long bristles) to the outer side of the 3-point hitch lever, with the front of the brush aligned to the edge of the fender.
- 4.4 Per fig. 4.2, install a self-drilling screw at each end of both sealing brushes into the tractor fender. Place the screw centered on the plastic brush holder, 1/4" to 1/2" from the end of the brush.

**CAUTION:** Operate the driver as slowly as possible while installing the self-drilling screws into the plastic, to avoid damage to the brush or fender.

### Hardware Used

#10 x 1/2" Self-Drilling Pan Head Screws Qty  
4

## STEP 5: (SIDEFAMES)

**Note:** For ease of handling, temporarily remove the doors from the side frames.

- 5.1 Remove and save the factory installed nut and washer from the outer front ROPS mounting stud (both sides). See Fig. 5.1. Install the side frame as shown. Re-install the washer and nut. Leave finger tight.
- 5.2 Fasten side frames to vehicle floor pan, under the floor mat. See Fig. 5.2a and 5.2b.
- Use the lock washer, longer button head bolt (35mm), split lock washer and larger fender washer (1-1/2") at the slot toward the rear of the cab floorboard into the weld nut in the tractor floorboard, under the floor mat.
  - Use the shorter button head bolt (20mm) and the smaller fender washer (24mm) through the floor mat and forward hole in the floorboard with an M8 nut under the tractor floorboard.
  - Leave fasteners finger tight.

**Note:** The rear outer corner holes in the floor mat will receive new pine tree clips after the full cab structure is assembled, and all fasteners are tightened.

### Hardware Used

M8 x 20mm Button Head Cap Screws (BHCS) Qty  
2  
M8 x 35mm Button Head Cap Screws (BHCS) 2  
M8 x 24mm Fender Washers 2  
5/16 x 1-1/2" Fender Washers 2  
M8 Lock Washer 2  
M8 Flanged Nut 2

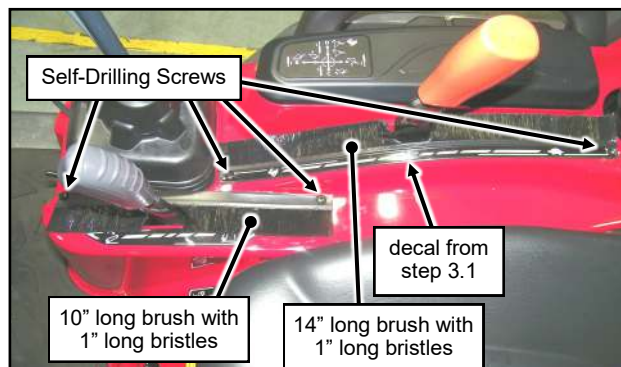

Fig. 4.2 (Attach Brushes to Right Fender)



Fig. 5.1 (ROPS Mounting Bolts)

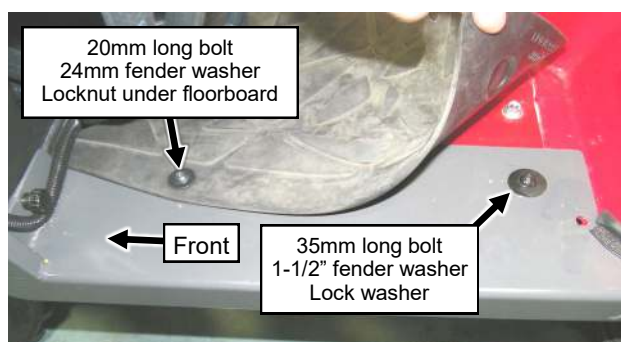

Fig. 5.2a (Floorboard Bolts, Left Side)

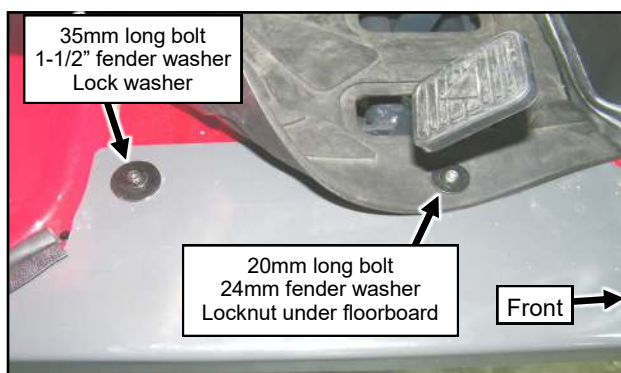

Fig. 5.2b (Floorboard Bolts, Right Side)

# CAB INSTALLATION

## STEP 6: (COWL)

6.1 Fasten the cowl to the side frames as shown in Figure 6.1. The foam seal in the center should lay across the dashboard and flex inwards towards the steering wheel.

### Hardware Used

5/16-18 FHCS  
5/16-18 Flange Nut

### Qty

4  
4

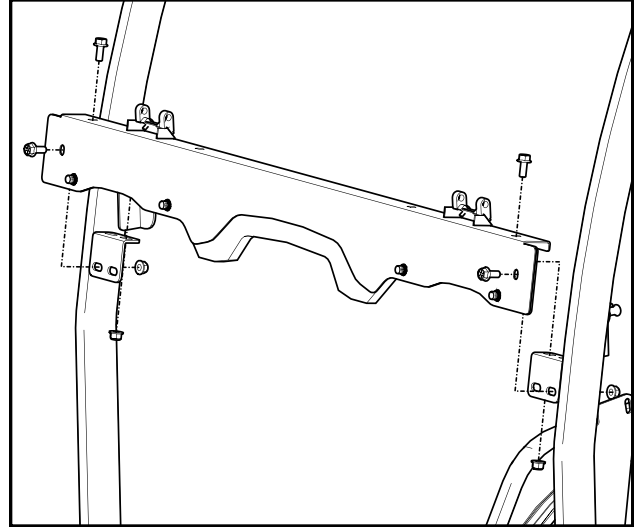

Fig. 6.1 (Cowl)

## STEP 7: (WINDSHIELD SUPPORT)

7.1 Install windshield support. See Fig. 7.1. Tighten at this time.

### Hardware Used

1/4-20 Truss Head Screws  
1/4-20 Flanged Nut

### Qty

4  
4

7.2 Install left side roof hinge pin as shown in Fig 7.2. Snug up the bolts. *Note: The right side roof hinge pin will be installed during roof installation at step 14.*

### Hardware Used

1/4-20 FHCS  
1/4-20 Flanged Nut

### Qty

2  
2

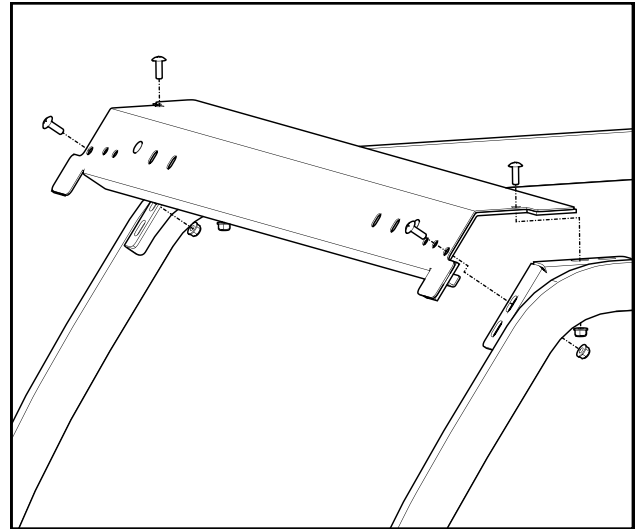

Fig. 7.1 (Windshield Support)

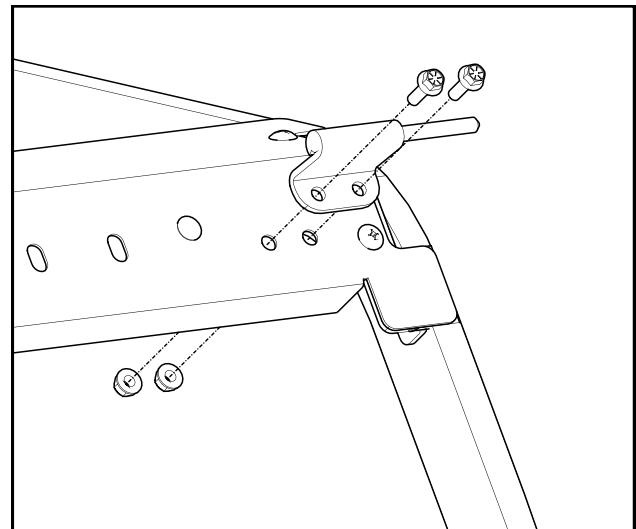

Fig. 7.2 (Windshield Support)



# CAB INSTALLATION

## STEP 8: (ROLL BAR BRACKETS)

8.1 Per Fig. 8.1, select the appropriate pair of roll bar brackets for the application. Discard whichever pair is not used.

### For tractors without backhoe:

If installing on a tractor with backhoe, proceed to step 8.3

8.2 Install the left ROPS bracket to the fixed ROPS as shown. Repeat on the right side. Leave bolts loose. See Fig. 8.2

<u>Hardware Used</u>	<u>Qty</u>
M8 x 65mm long FHCS (Removed from vehicle in step 1.2)	4
M8 Flanged Nut	4

### For tractors with backhoe:

If installing on a tractor without backhoe, see step 8.2 above.

8.3 Install the left ROPS bracket to the folding ROPS as shown. Repeat on the right side. Tighten all hardware. See Fig. 8.3

<u>Hardware Used</u>	<u>Qty</u>
M8 x 65mm long FHCS (Removed from vehicle in step 1.2)	4
M8 Flanged Nut	4

### All Tractor Models:

8.4 Reinstall Vehicle lights to open position on ROPS brackets. See Fig. 8.2 or 8.3, depending on vehicle model. Feed wire down through ROPS and reconnect under vehicle fender.

<u>Hardware Used</u>	<u>Qty</u>
M8 x 30mm long FHCS	4

**IMPORTANT: The rear light wiring must be routed through the ROPS tubes before installing the Rear Legs.**

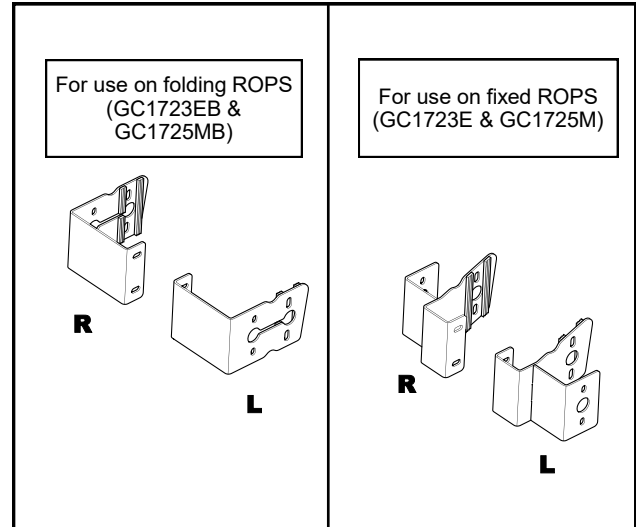

Fig. 8.1 (Roll Bar Bracket Options)

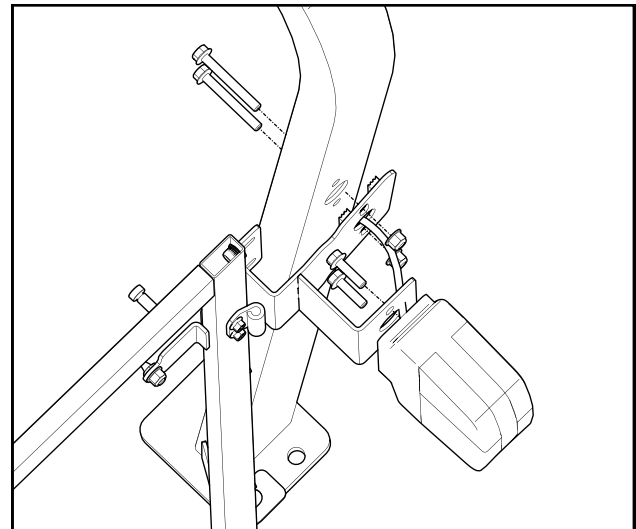

Fig. 8.2 (Non-Folding ROPS Brackets)

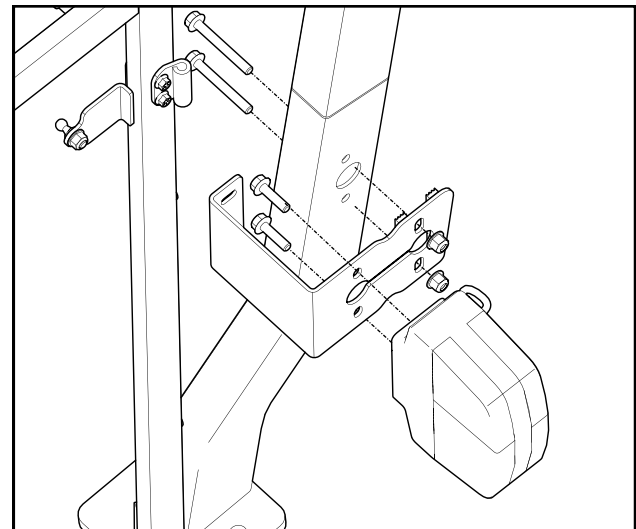

Fig. 8.3 (Folding ROPS Brackets)

# CAB INSTALLATION

## FOR TRACTOR WITHOUT BACKHOE INSTALLATIONS:

*Note: If installing cab onto tractor with backhoe, skip to step 11 on the next page.*

### STEP 9: (HARD REAR PANEL)

9.1 Set the hard rear panel into position in front of the ROPS tubing and lean it backwards at the top so it rests in place temporarily. See Fig. 9.1

### STEP 10: (REAR LEGS)

10.1 With assistance, install the left side rear leg oriented as shown. See Fig. 10.1. Fasten to the side frame and ROPS brackets. Leave finger tight. Repeat for right rear leg.

<u>Hardware Used</u>	<u>Qty</u>
5/16-18 FHCS	14
5/16-18 Flange Nut	6

10.2 Lift rear panel and slide the upper pins into the receivers on the rear legs. Engage the lower quick release latches at this time. See Fig. 10.2.

*Note: The quick release latches require (2) clicks to be fully locked. Press the rear panel in from the outside in these locations to double click the latches.*

10.3 Align the top of the rear legs to the top of the side frames and tighten all rear leg fasteners.

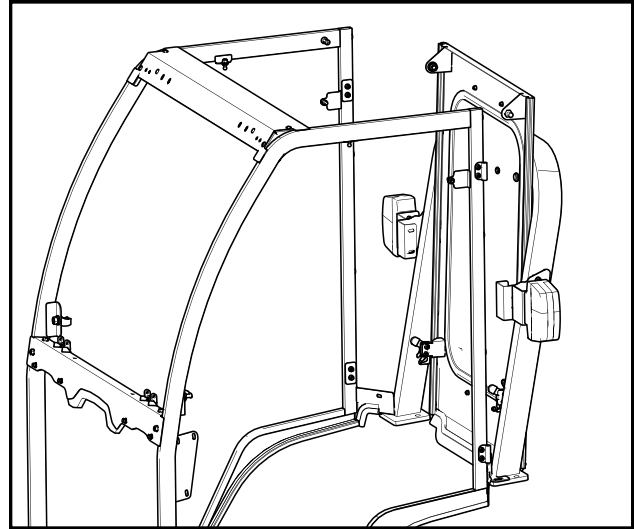

Fig. 9.1 (Rear Panel Installation)

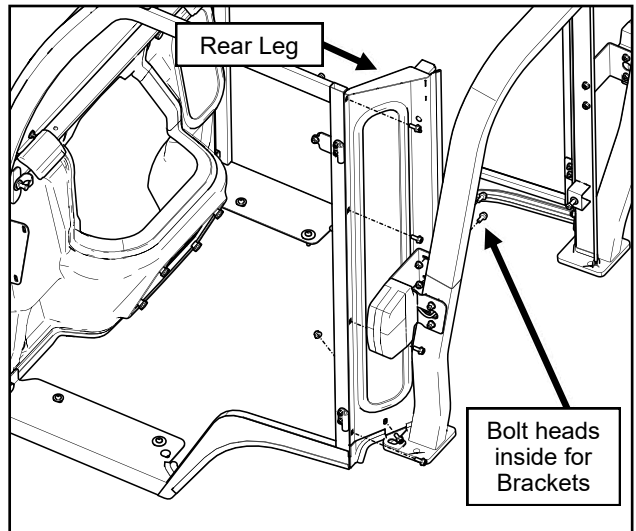

Fig. 10.1 (Rear Leg Installation)

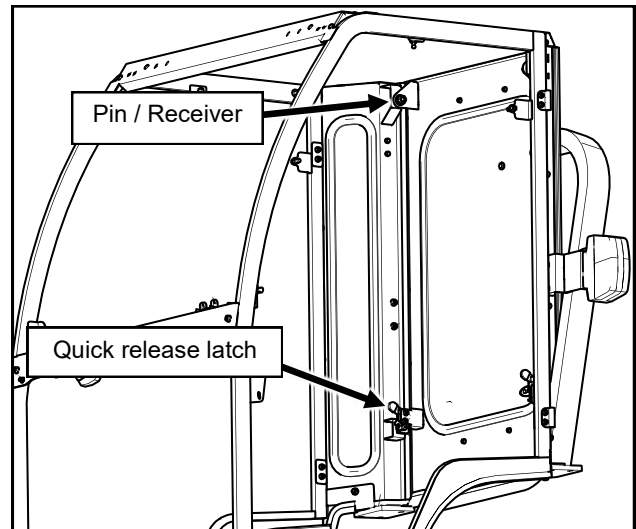

Fig. 10.2 (Rear Leg / Rear Panel Engagement)

# CAB INSTALLATION

## FOR TRACTOR WITH BACKHOE INSTALLATIONS:

*Note: If installing cab onto tractor without backhoe, skip to step 13 on the next page.*

### STEP 11: (REAR LEGS)

11.1 With assistance, install the left side rear leg oriented as shown. See Fig. 11.1. Fasten to the side frame and ROPS brackets. Align the top of the rear legs to the top of the side frames and tighten all fasteners. Repeat for right rear leg.

#### Hardware Used

5/16-18 FHCS

5/16-18 Flange Nut

#### Qty

14

6

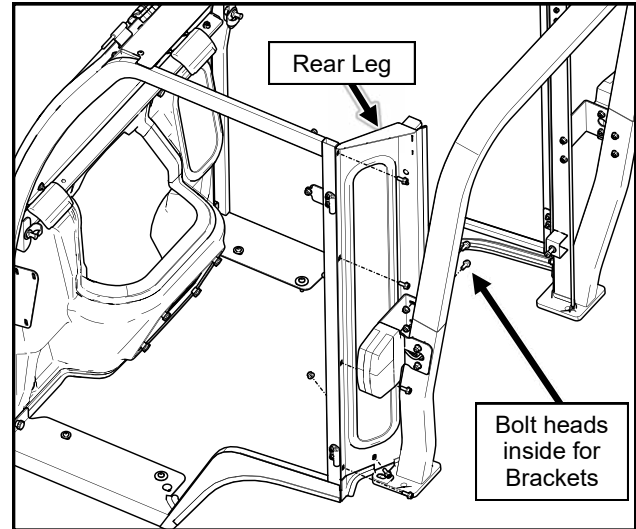

Fig. 11.1 (Rear Leg Installation)

### STEP 12: (HARD REAR PANEL)

12.1 Lift rear panel and slide the upper pins into the receivers on the rear legs. Engage the lower quick release latches at this time. See Fig. 12.1.

*Note: The quick release latches require (2) clicks to be fully locked. Press the rear panel in from the outside in these locations to double click the latches.*

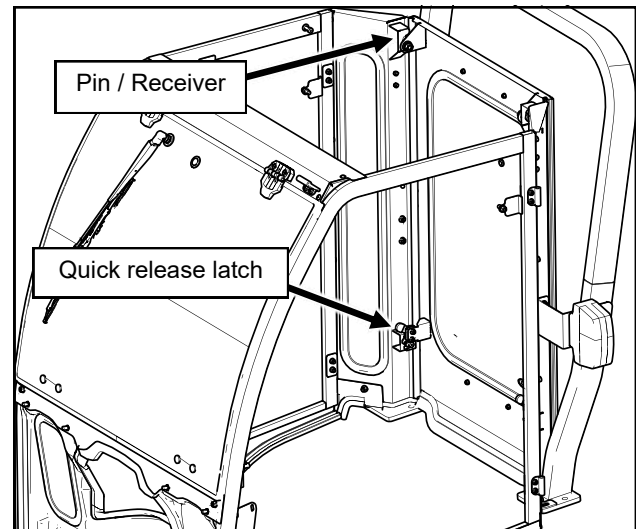

Fig. 12.1 (Rear Panel Installation)

# CAB INSTALLATION

## STEP 13: (WINDSHIELD)

**13.1** Install the windshield to the windshield support using (1) plastic spacer block underneath each upper plastic hinge to space it off the windshield support. Snug fasteners, but **do not tighten fully**. See Fig. 13.1.

Hardware Used	Qty
5/16-18 X 1-1/2" long Flat Head Screws	4
5/16-18 Flanged Nut	4
Plastic Spacer Blocks	2

**13.2** Compress the spring loaded tabs on the pop-out windshield latches and engage the plastic pins into the receiver tabs mounted to the top of the cowl. Close pop-out latches.

**13.3** Tighten windshield fasteners.

**Caution:** The windshield hinges are plastic components. Do not over tighten the 5/16-18 flat head screws. Torque to 7 ft.-lbs. max.

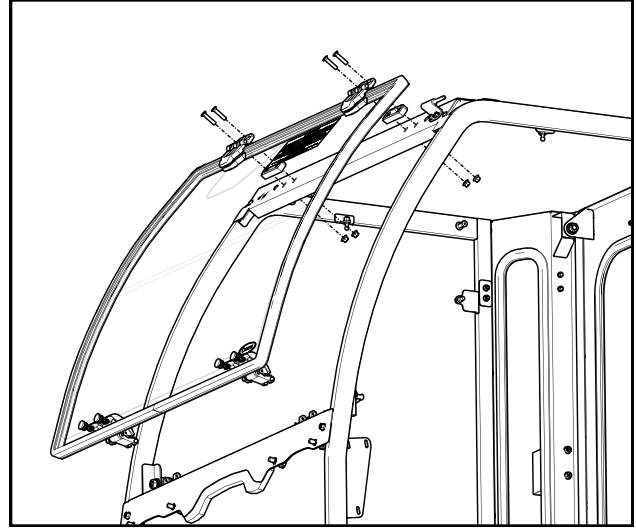

Fig. 13.1 (Windshield Installation)

## STEP 14: (ROOF)

**14.1** With assistance, lift the roof onto the side frames. See Figure 14.1. *Take care not to engage the quick release latches with the side frame latch pins.*

Move the roof into position, such that the previously installed hinge pin mates with the factory installed sleeve on the roof. *Note: It may be necessary to loosen the hinge pin fasteners installed in Step 7.2.*

Move the rear section of the roof into position to engage the quick release latches.

Once the roof is in place, install the final hinge pin on the other side. Ensure that the roof is square to the side frames and tighten hinge fasteners.

Hardware Used	Qty
1/4-20 FHCS	2
1/2-20 Flanged Nut	2

**14.2** Disengage the roof latches, manually lift the roof, and install the gas shocks. See Fig. 14.2. *Note: Orient the gas shocks so that the piston rod is pointing down for best, continuous seal lubrication and longest gas shock life.*

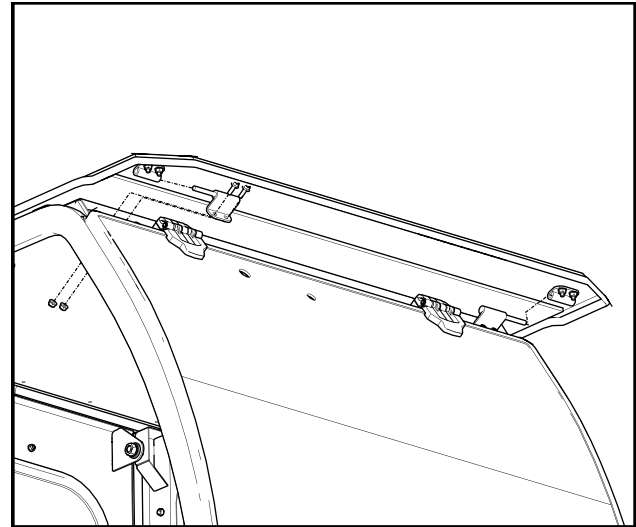

Fig. 14.1 (Roof Installation)

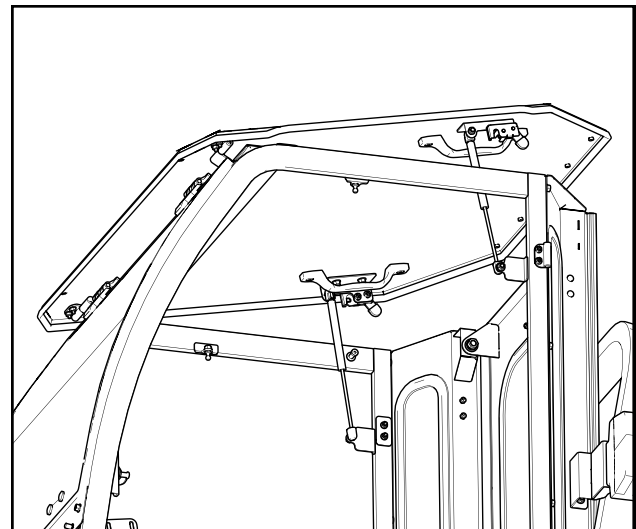

Fig. 14.2 (Roof Gas Shock Installation)

# CAB INSTALLATION

## STEP 15: (WIPER KIT)

- 15.1 Install the wiper motor to the windshield per the diagram included in the wiper hardware kit.
- 15.2 Cover the Wiper Wiring Harness with wire loom and connect the harness to the wiper motor.
- 15.3 For best results, run the wires across the windshield support towards the left, down the inside of left front frame tube and attach the wires with self-drilling screws and P-clamps, prior to installing the radiator shroud. See Fig 15.3.
- 15.4 Run the wires through the front of the brake pedal slot in the floorboard, under the metal shroud on the left of the tractor engine and up to the battery.
- 15.5 Cut wires to length, attach the fuse holder to the red wire with the supplied butt connector and ring terminals to both wires.
- 15.6 Attach the red wire to the positive battery terminal, then the black wire to negative.
- 15.7 Attach the wiper harness to the windshield support and to the tractor at the left of the battery with wire ties.
- 15.8 Once the battery is re-connected, turn the switch on the wiper on then off to verify function and ensure the motor stops in the park position.
- 15.9 Install the wiper arm with the arm fully extended and pointed toward the lower right corner of the windshield. See Fig. 15.9.

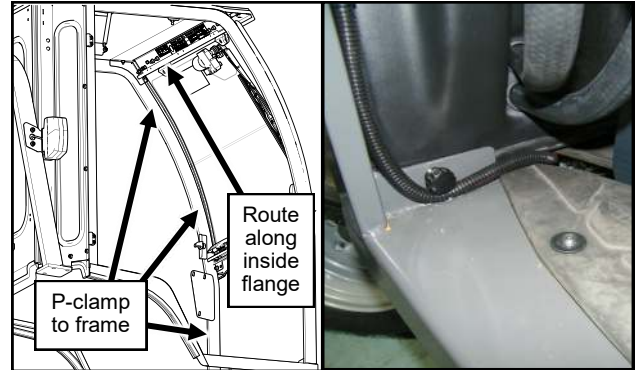

Fig. 15.3 (Wiper Wiring)

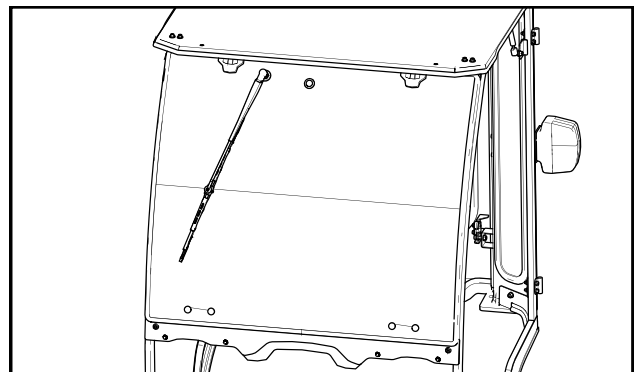

Fig. 15.9 (Wiper Arm Orientation)

## STEP 16: (RADIATOR SHROUD)

- 16.1 With assistance, install the Radiator Shroud as shown from the inside of the cab. See Fig. 16.1a and 16.1b. Make sure the radiator shroud is on the outside of the flanges at the front of the cab floorboards, with the threaded studs through the holes in the floorboards.

### Tips:

- The plastic shroud will need to flex to fit around the heater bracket on the cab, and the parking brake and throttle levers on each side of the tractor instrument console. For best seal, tuck the rubber down along the back of the instrument panel and forward along the sides.
- Block the tractor wheels and release the park brake.
- Position the left side bottom of the shroud in front of the brake pedal and floorboard leaving the right side angled to the rear of the tractor, just in front of the forward reverse pedals.
- Tuck the left edge against the side frame in front of the heater bracket then begin working toward the center, flexing around the park brake lever.
- Position the bottom of the right side in front of the floorboard and flex around the throttle lever.
- Pull and pry the shroud as required to get onto the mounting studs.
- For additional help, watch the installation video available at [Curtisindustries.net](http://Curtisindustries.net) or via the QR code on the next page.

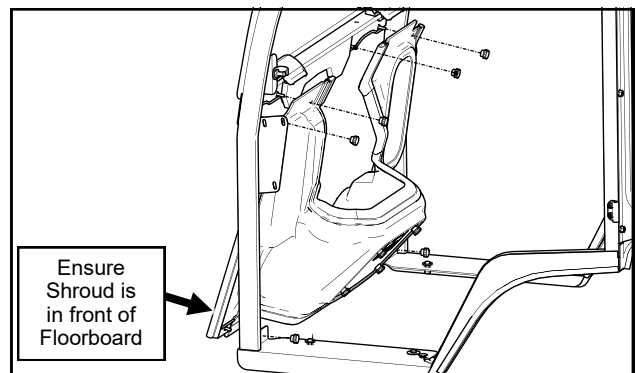

Fig. 16.1a (Radiator Shroud Installation)

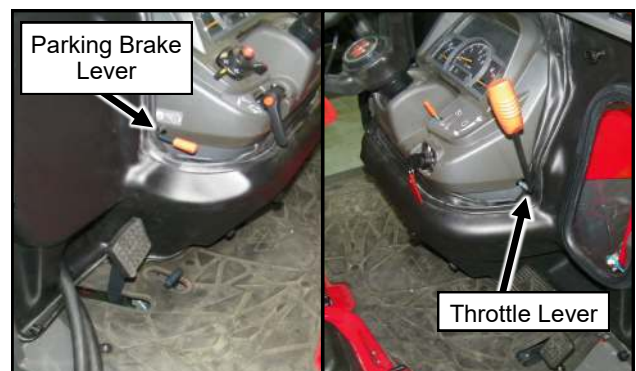

Fig. 16.1b (Radiator Shroud Installation)

# CAB INSTALLATION

## STEP 16: (RADIATOR SHROUD cont.)

16.2 Attach the Radiator Shroud to the cab with Thumb Nuts: one at each floorboard and two on each side of the cowl. See Fig. 16.1a.

**Hardware Used**  
1/4-20 Thumb Nuts

**Qty**  
6

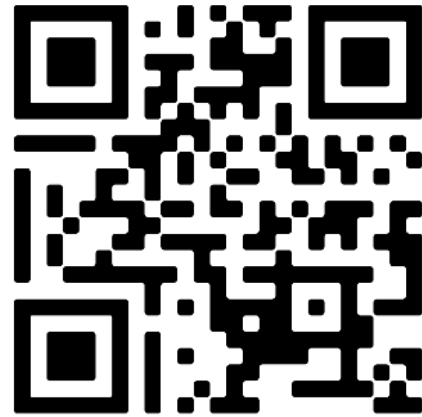

## STEP 17: (TIGHTEN ALL FASTENERS)

17.1 Tighten all fasteners and re-check all previously installed fasteners to ensure that they have been properly tightened. Torque OEM ROPS nuts on rear brackets to 55 ft.-lbs. Use the torque tables on pages 21 and 22.

17.2 Install new Pine Tree Clips through the rear of each side of the floor mat, through the cab and tractor floorboards. See Fig. 17.2.

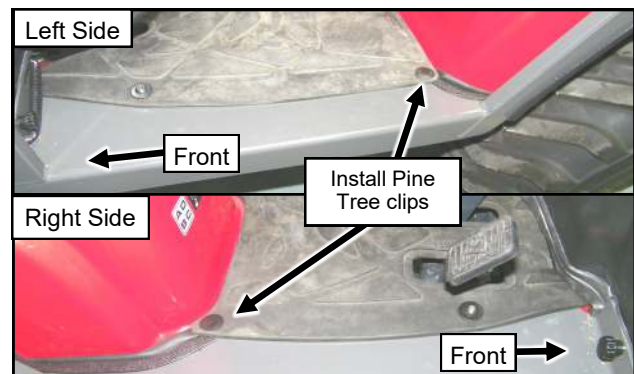

Fig. 17.2 (Floor Mat Pine Tree Clips)

## STEP 18: (UNDER SEAT FILLER)

18.1 Install the rubber under seat filler as shown using the supplied self-adhesive Velcro around the perimeter to match the Velcro sewn into the rubber panel. See Fig. 18.1 and 18.2.

*Note: Apply to a clean, dry surface at room temperature for best adhesion.*

*Note: The rear of the under seat filler is meant to fit on top of the hard fixed rear panel, with the Velcro adhered to the rear of the tractor just forward of the warning decals.*



Fig. 18.1 (Under Seat Filler)



Fig. 18.2 (Under Seat Filler)

# CAB INSTALLATION

## STEP 19: (DOORS)

**19.1** Grease the hinge pins and re-install the doors into their respective hinge sleeves located on the side frames. See Fig. 19.1

*Note: Holding the door perpendicular to the side frame will ease installation. If hinge pins don't initially bottom out, rotate the door back and forth until hinges are seated properly.*

**19.2** Install the door gas shocks oriented so that the piston rod is pointing downhill (toward door) for best, continuous seal lubrication and longest gas shock life.

**19.3** The doors should “double click” for full engagement and proper closure. If necessary, make the following adjustments in this order:

- Adjust the striker pin on the side frame vertically - See Fig. 19.3a
- Adjust the latch located inside the door horizontally - See Fig. 19.3b
- Adjust the hinges located at the rear of the door - See Fig. 19.3c

*Note: The quickest, most common solution is to adjust the striker pin position on the side frame using two 3/4" open-end wrenches.*

**19.4** Once the doors are properly adjusted, lubrication (preferably grease) can be applied to the door striker pins and door latch assemblies.

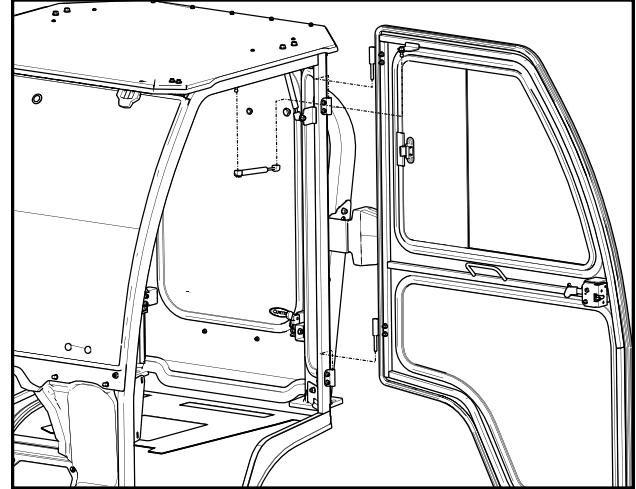

Fig. 19.1 (Door Installation)

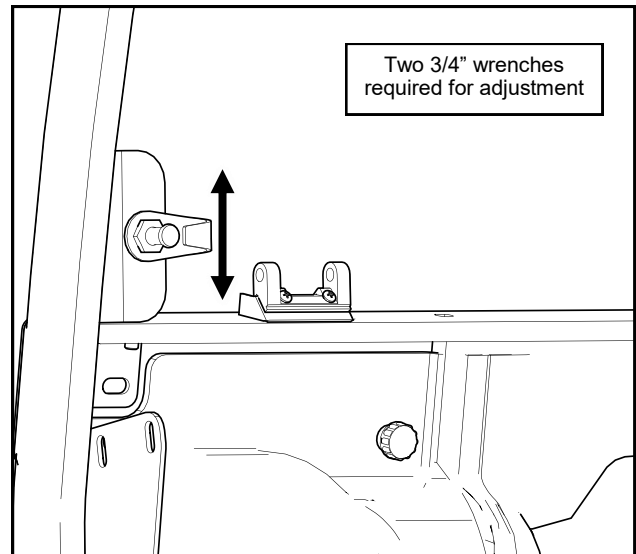

Fig. 19.3a (Door Striker Pin Adjustment)

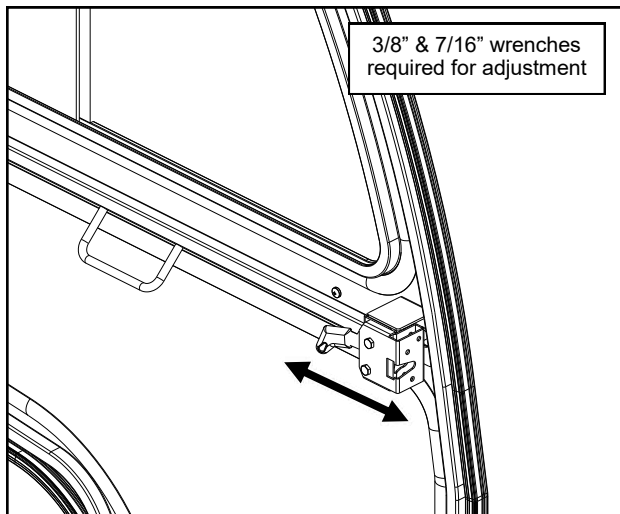

Fig. 19.3b (Door Latch Adjustment)

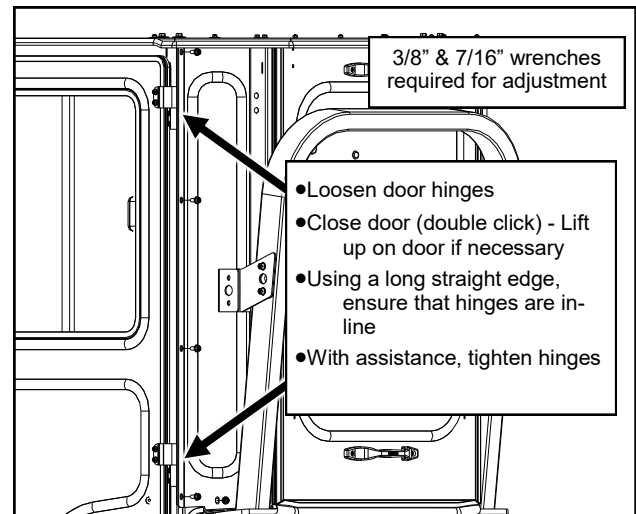

Fig. 19.3c (Door Hinge Adjustment)

# CAB INSTALLATION

## STEP 20: (SMV SIGN BRACKET)

### For GC1723EB & GC1725MB Tractor Models Only

- 20.1** Retrieve the SMV sign bracket removed in step 1. See Fig. 20.1
- 20.2** Remove the SMV sign receiver from the black bracket and flip it over so the wide end of the taper is now facing down. See Fig. 20.2.
- 20.3** Remove the OEM nut and washer from the rear-most ROPS mounting stud on the left hand side of the vehicle. Reinstall the SMV sign bracket onto this stud, as shown in Fig. 20.3. Retighten nut to 55 ft-lbs.

*Note: The bracket should now be installed inverted to how it was originally installed on the vehicle to provide clearance for the door.*

## STEP 21: (SMV SIGN)

### For All Tractor Models

- 21.1** Install the SMV sign into one of the receivers on the vehicle.

## STEP 22: (FINISHING TOUCHES)

- 22.1** Place rubber caps over the six nuts at the front of the cab; four on the front of the Cowl and one at each side of the bottom of the Radiator Shroud. See Fig. 22.1.
- 22.2** Due to the nature of the packaging materials used for shipping this product, the components of the cab system may have dust on their surfaces upon removal from the packaging. It is recommended that after completion of the cab installation, the cab and vehicle are washed thoroughly to eliminate any dust or contaminants. See the Care and Maintenance section at the back of this manual for critical information on cleaning the product.

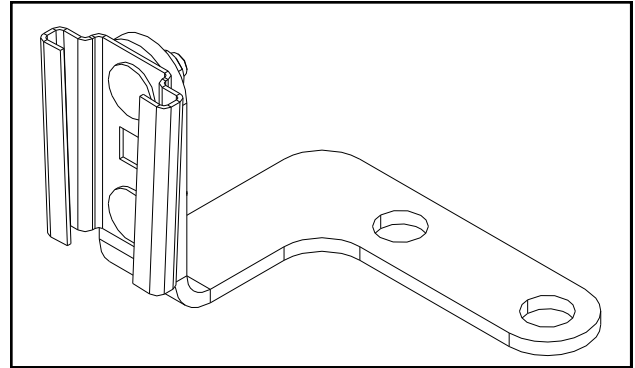

Fig. 20.1 (SMV Sign Bracket - Original)

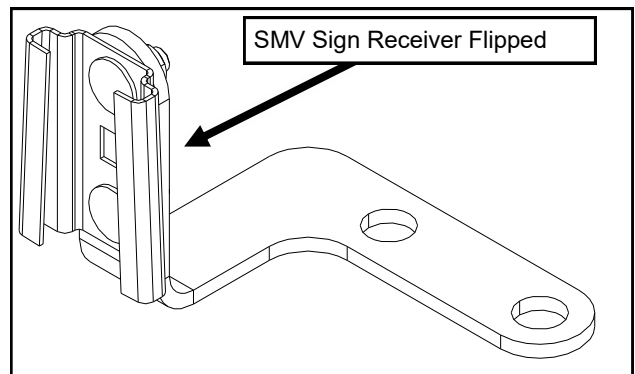

Fig. 20.2 (SMV Sign Bracket - Flipped)

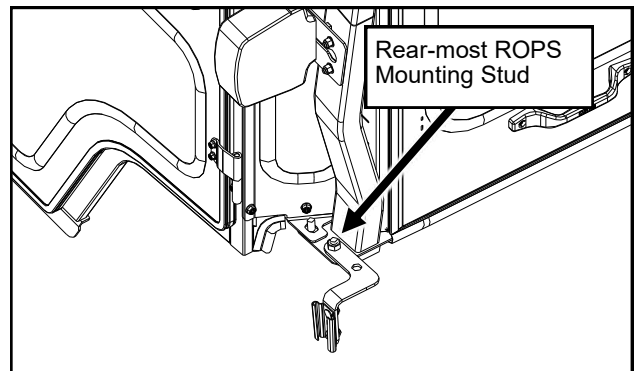

Fig. 20.3 (SMV Sign Bracket - Installed)

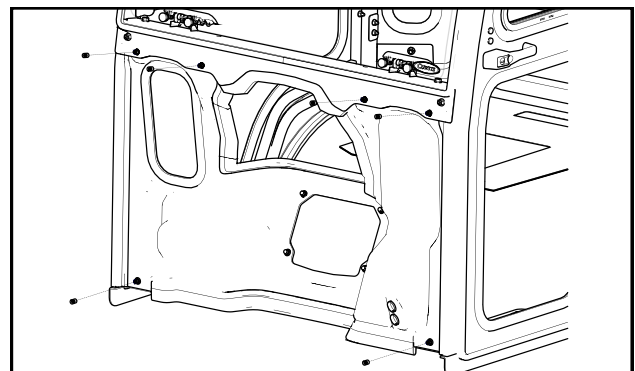

Fig. 22.1 (Caps for Insert Nuts)



# CAB FEATURES & OPERATION

## POP-OUT WINDSHIELD

Your GC1723 series cab comes equipped with a pop-out windshield for ventilation. To open the windshield, simply lift up on both of the pop-out latches and rotate until the latches rest in the over-center position.

## LIFT-OFF DOORS

For added ventilation, the doors on the GC1723 series cab lift off in seconds without tools.

To lift off:

- 1) Disconnect the gas shock from the side frame by depressing the orange activator.
- 2) Rotate the doors 90° to the sideframe and lift. Also, remove the hinge washers and store in a plastic bag. *Store the doors in a safe location to prevent damage.*

## POP-UP ROOF

This cab features a hinged and gas shock supported roof. This feature allows for backhoe operation on GC1723EB & GC1725MB vehicle models, as well as provides additional ventilation on all vehicle models.

To operate the roof, press up on the yellow lever on the quick release latches. It may help to pull down slightly on the grab handles while releasing the latches.

To lock the roof in the down position, simply pull down on the plastic grab handles until each latch has double clicked. *Note: Pull down on each handle at the same time to ensure accurate positioning of the latches.*

## REMOVABLE HARD REAR PANEL

In order to use the backhoe on GC1723EB & GC1725MB model vehicles, some conversion of the cab is necessary. First raise the roof per the instructions above then remove the rear panel.

To remove the rear panel:

- 1) Release the two latches towards the bottom of the rear panel. *It may be necessary to push out on the lower section of the rear panel to prevent the latches from re-engaging.*
- 2) From outside of the cab, lift up on the rear panel and pull towards the backhoe. *Store the rear panel in a safe location to prevent damage.*

To reinstall the rear panel, simply align the pins at the top with the receivers on the rear legs and drop into place. Push in on the lower corners of the rear panel to ensure double latching of the quick release latches.

After re-installing the rear panel, check that the rubber underseat filler is flat against the bottom of the rear panel and flatten it out if necessary.

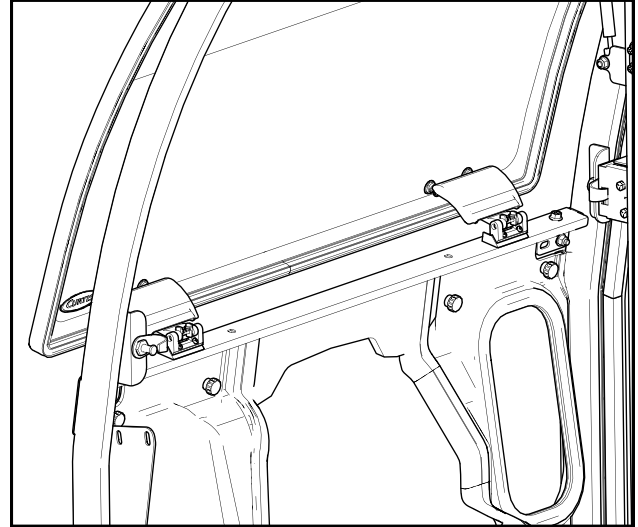

Pop-Out Windshield

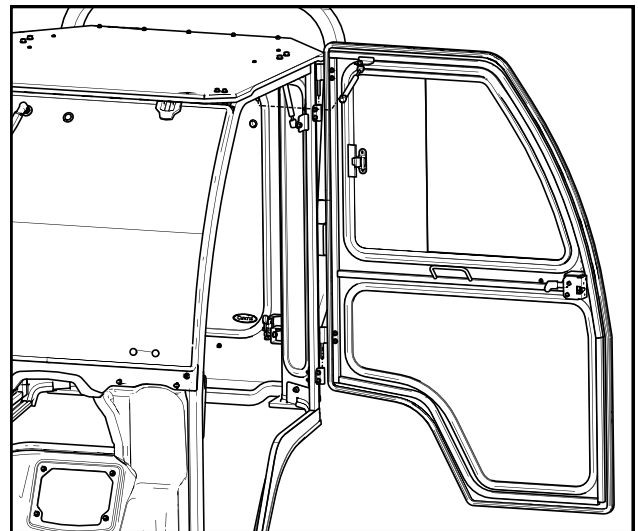

Lift-Off Doors

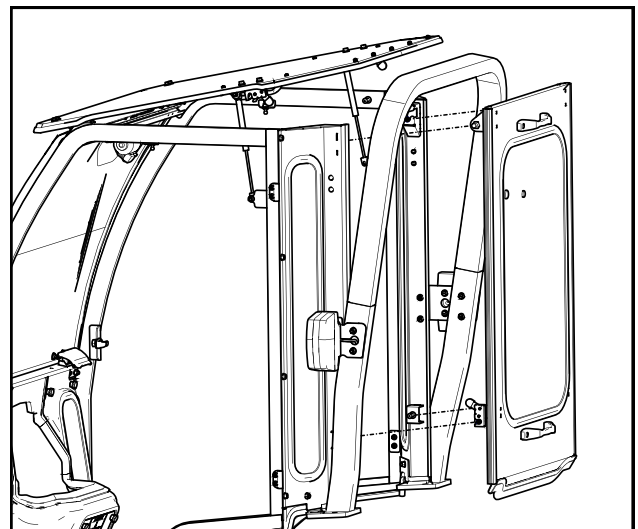

Removable Rear Panel

## CAB FEATURES & OPERATION

### REMOVABLE RADIATOR SHROUD PANEL

Your GC1723 series cab comes equipped with a removable metal panel for extra air flow on hot summer days. Should your temperature gauge climb on a hot day follow this procedure:

1. Make sure you provide ventilation to the cab by venting windshield, venting or removing rear window or removing doors.
2. Remove the metal panel to allow additional air flow to the radiator.

**Warning!** Never remove the panel without ventilating the cab. This may cause carbon Monoxide to be drawn into the cab, Carbon Monoxide can cause illness, serious injury or death.

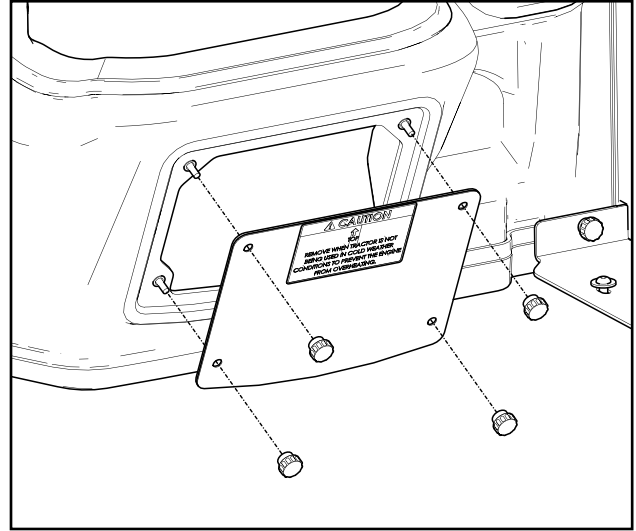

Removable Radiator Shroud Panel

## CARE AND MAINTENANCE

- Re-apply lubrication (preferably grease) periodically as needed to the door striker pins, door latch assemblies, and the door hinges.
- Check and tighten hardware after 40 hours of operation. Periodically inspect and tighten hardware for the remainder of the unit's life.
- Wash the painted surfaces of the cab with commercial automotive cleaning products.
- Clean glass windows with glass cleaner. *Note: Some windows on the cab are acrylic. DO NOT clean acrylic windows with harsh chemicals. It will damage the plastic. Mild soap and water should be used on all acrylic windows.*
- Vinyl components should be washed with a mild solution of warm soapy water.
- If it becomes necessary to clean the perforated metal screen below the steering wheel and behind the radiator shroud, you can do so by removing the radiator shroud panel (reference top of this page) and cleaning out from the sides with compressed air. *Note: The radiator screen directly in front of the Radiator should be cleaned out as recommended in the service manual just the same as if there was no cab installed.*

# MASSEY FERGUSON GC1723 CAB SERVICE PARTS

ROOF ASSEMBLY  
P/N: 8SV-GC1701-R3

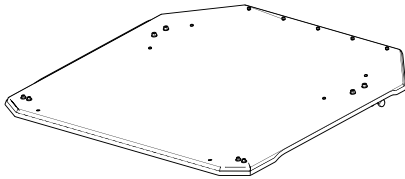

WINDSHIELD ASSEMBLY  
P/N: 8SV-CI02

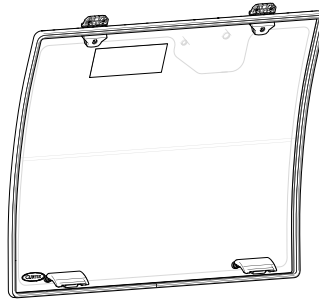

WINDSHIELD SUPPORT ASSEMBLY  
P/N: 8SV-GC179504-R3

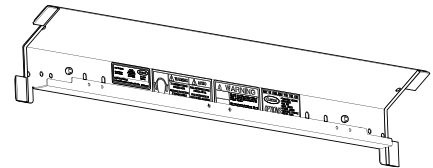

COWL ASSEMBLY  
P/N: 8SV-105-00021

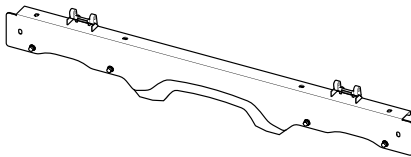

REAR PANEL ASSEMBLY  
P/N: 8SV-106-00029

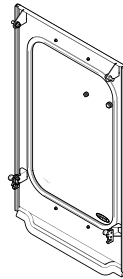

DOOR ASSEMBLY  
P/N: 8SV-107-00034-L (Left)  
P/N: 8SV-107-00034-R (Right)

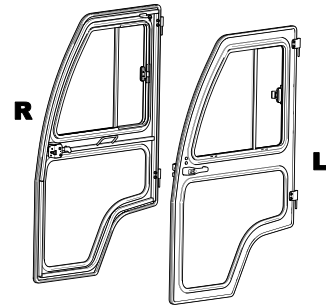

REAR LEG ASSEMBLY  
P/N: 8SV-108-00018-L (Left)  
P/N: 8SV-108-00018-R (Right)

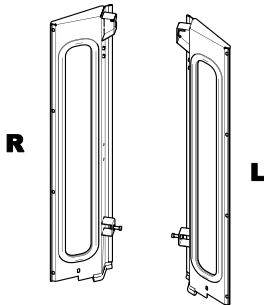

SIDE FRAME ASSEMBLY  
P/N: 8SV-109-00014-L (Left)  
P/N: 8SV-109-00014-R (Right)

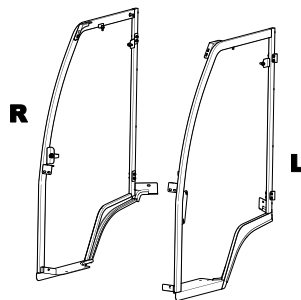

RADIATOR SHROUD ASSEMBLY  
P/N: 8SV-111-00023

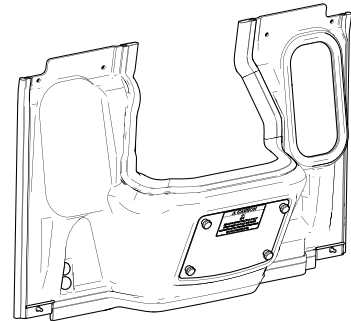

ROPS BRACKET ASSEMBLY,  
FOLDING ROPS  
P/N: 8SV-GC1710L-G1 (Left)  
P/N: 8SV-GC1710R-G1 (Right)

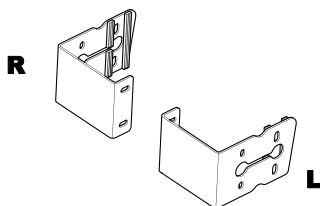

ROPS BRACKET ASSEMBLY,  
NON-FOLDING ROPS  
P/N: 8SV-110-00060-L (Left)  
P/N: 8SV-110-00060-R (Right)

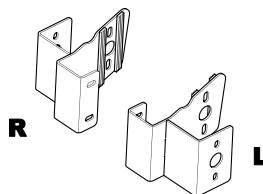



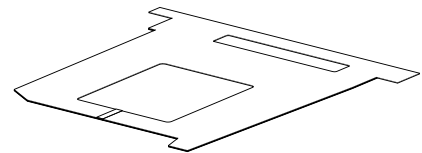









UNDER SEAT FILLER ASSEMBLY  
P/N: 8SV-112-00035



## ADDITIONAL SERVICE PARTS

PART NUMBER	DESCRIPTION
8SV-PGGC17RLW	REAR LEG WINDOW WITH RUBBER
8SV-PGGC17DLW	DOOR LOWER WINDOW WITH RUBBER
8SV-SWGC17-L	SLIDER ASSEMBLY, LEFT, WITH RUBBER
8SV-SWGC17-R	SLIDER ASSEMBLY, RIGHT, WITH RUBBER
8SV-P-00098	COWL WINDOW WITH RUBBER
9SV-HWK-00114	HARDWARE KIT, GC1723
9SV-GS02Q	GAS SHOCK (12") WITH QUICK RELEASE END (FOR DOOR AND ROOF)
9SV-HWSS	WINDSHIELD HINGE KIT WITH SHORT SPACER
9SV-HSLP	HINGE SET - LOW PROFILE, BLACK ZINC
9SV-IHRL	INSIDE HANDLE ROTARY LATCH KIT
9SV-OHRL	OUTSIDE HANDLE ROTARY LATCH KIT
9SV-WL1	WINDSHIELD LATCH KIT 1
9PWM110	WINDSHIELD WIPER MOTOR 110°
9PWA14/16	WINDSHIELD WIPER ARM, ADJUSTABLE LENGTH (14" - 16")
9PWB20-FB	WIPER BLADE, 20" - FLEX
9SV-GS02A	BALL STUDS, 10MM (BAG OF 10)
9SV-DP01	DOME PLUG 7/16" (BAG OF 15)
9SV-DP04	DOME PLUG 1-1/8" (BAG OF 15)
9SV-GH	GRAB HANDLE KIT (SET OF 2)
9SV-DSTRH	DOOR STRIKER KIT - INCLUDES CASE HARDENED STRIKER BOLT
9SV-RFL	ROOF LATCH KIT (INCL. L & R)
9DL01H	KEY FOR OUTSIDE HANDLE, ROTARY LATCH (SET OF 2)

TRIM LOK, STD, 1/16" - 1/8" GRIP	5/8" STD BULB, 1/16" GRIP	1" FLAT BULB, 1/16" GRIP	5/8" STD BULB, 1/4" GRIP	WINDOW RUBBER	3/4" SIDE BULB, 1/16" GRIP	1" ROUND BULB, 1/16" GRIP
						
9SV-PRO1-20	9SV-PRO2-15	9SV-PRO5-10	9SV-PRO7-5	9SV-PR10-20	9SV-PR17-20	9SV-PR19-10
1/2" WEATHERSEAL	3/4" SIDE BULB, 1/4" GRIP	FOAM TAPE, 1/8" X 1"	1-1/2" SIDE BULB, 1/16" GRIP	RUBBER FOAM, 1/2" X 9/16"	ARCH PSA, .20" X.15"	
						
9SV-PR20-10	9SV-PR38-15	9SV-PR39-5	9SV-PR41-5	9SV-PR43-4	9SV-PR53-15	

## OPTIONAL ACCESSORIES

FRONT LED WORK LIGHTS (P/N: 9LEDW4)

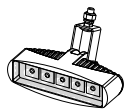

REAR LED WORK LIGHTS (P/N: 9LEDW3)



STROBE LIGHT (P/N: 9LEDS2)

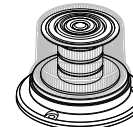

DOME LIGHT (P/N: 9LEDD14)



HEATER (P/N: 9PH20S54)

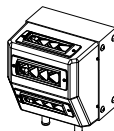

SWITCH PANEL (P/N: 9PSF1)

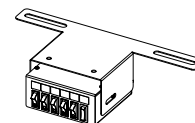

SIDE VIEW MIRRORS (P/N: 9PM5)

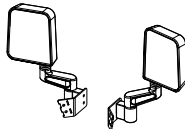

REAR VIEW MIRROR (P/N: 9PM3)

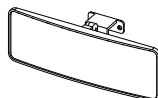

REAR WIPER KIT, 85 DEGREE SWEEP, 12V W/ 16" FLEX BLADE (P/N: 9PWK85F)

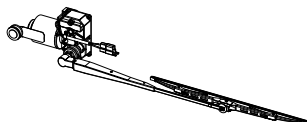

FRONT WIPER KIT, 110 DEGREE SWEEP, 12V W/ 20" FLEX BLADE (P/N: 9PWK110)

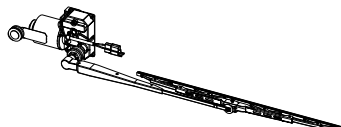

## Tightening of Non-Structural Bolts

For light or medium duty fastening, Curtis recommends using a general industry standard of tightening until snug and then giving an additional one quarter turn of the tool as deemed reasonable for the application (i.e.: at the installer's discretion).

If torque values are required, the examples listed below are intended as a reasonable reference for use in the majority of non-structural fastener applications such as: small diameter fasteners; bolts passing thru tubing, glass, plastic, nylon or rubber washers, threaded inserts, etc.

If more than one application below applies, use the lower torque value.



FASTENER SIZE:	FASTENER TYPE:	WASHER MATERIAL:	APPLICATION:	TORQUE (INCH-POUNDS) (±5)
#10	Machine Screws	-	in Nylon P-Clamps	20
#10	Machine Screws	-	Strobe Light (plastic base)	35
M5	Set Screws	-	Wiper Arm	20
1/4"	Cap Nut	-	Windshield Wiper	20
1/4"	Bolts	-	Tubing (5/8" to 3/4" wide)	132
1/4"	Bolts	Rubber	-	60
1/4"	Bolts	Nylon / Plastic	-	72
1/4"	Bolts	-	Factory Installed Threaded Inserts	132
5/16"	Bolts	-	Tubing (1" or wider)	60
5/16"	Flat Head Bolts	-	Plastic Windshield Hinge	79
5/16"	Bolts	Rubber	-	120
5/16"	Bolts	Nylon / Plastic	-	150
5/16"	Ball Studs	-	-	150
5/16"	Bolts	-	Factory Installed Threaded Inserts	240
3/8"	Bolts	-	Tubing	120
M12	Door Striker Pins	-	-	120

# Torque Specs. for Structural Bolts

This page is for use primarily when dealing with high-strength vehicle fasteners such as ROPS hardware that hold the structure together for safety. This page can also be used for other solid metal-to-metal joints. **Do not** use these high torque values on any of the following applications involving: tubing, plastic, nylon or rubber washers, threaded inserts, etc.. See next page regarding less critical fasteners.

The values below apply to fasteners that are dry or lubricated with normal engine oil. They do not apply if special graphited or moly disulphide greases or other extreme pressure lubricants are used. This applies to both UNF and UNC threads. Remember to always use the same grade or property class when replacing bolts.

**IMPORTANT: on all PLATED GRADE 8 bolts, reduce torque 15% from listed bolt torque specification.**

SAE Grade No.		2				5				8*				
Bolt head identification mark as per grade. NOTE: Manufacturing Marks Will Vary														
		TORQUE		TORQUE		TORQUE		TORQUE		TORQUE		TORQUE		
Bolt Size	Inches	Millimeters	Pounds Feet		Newton-Meters		Pounds Feet		Newton-Meters		Pounds Feet		Newton-Meters	
			Min.	Max.	Min.	Max.	Min.	Max.	Min.	Max.	Min.	Max.	Min.	Max.
1/4	6.35		5	6	7	8	9	11	12	15	12	15	16	20
5/16	7.94		10	12	14	16	17	20.5	23	28	24	29	33	39
3/8	9.53		20	23	27	31	35	42	48	57	45	54	61	73
7/16	11.11		30	35	41	47	54	64	73	87	70	84	95	114
1/2	12.70		45	52	61	70	80	96	109	130	110	132	149	179
9/16	14.29		65	75	88	102	110	132	149	179	160	192	217	260
5/8	15.88		95	105	129	142	150	180	203	244	220	264	298	358
3/4	19.05		150	185	203	251	270	324	366	439	380	456	515	618
7/8	22.23		160	200	217	271	400	480	542	651	600	720	814	976
1	25.40		250	300	339	406	580	696	787	944	900	1080	1220	1464
1-1/8	25.58		-	-	-	-	800	880	1085	1193	1280	1440	1736	1953
1-1/4	31.75		-	-	-	-	1120	1240	1519	1681	1820	2000	2468	2712
1-3/8	34.93		-	-	-	-	1460	1680	1980	2278	2380	2720	3227	3688
1-1/2	38.10		-	-	-	-	1940	2200	2631	2983	3160	3560	4285	4827

\*Thick Nuts must be used with Grade 8 bolts

## METRIC BOLT TORQUE SPECIFICATIONS



Size of Screw	Property Class	Course Thread			Fine Thread		
		Pitch (mm)	Pounds Feet	Newton-Meters	Pitch (mm)	Pounds Feet	Newton-Meters
M6	5.6	1.0	3.6-5.8	4.9-7.9	-	-	-
	8.8		5.8-9.4	7.9-12.7		-	-
	10.9		7.2-10	9.8-13.6		-	-
M8	5.6	1.25	7.2-14	9.8-19	1.0	12-17	16.3-23
	8.8		17-22	23-29.8		19-27	25.7-36.6
	10.9		20-26	27.1-35.2		22-31	29.8-42
M10	5.6	1.5	20-25	27.1-33.9	1.25	20-29	27.1-39.3
	8.8		34-40	46.1-54.2		35-47	47.4-63.7
	10.9		38-46	51.5-62.3		40-52	54.2-70.5
M12	5.6	1.75	28-34	37.9-46.1	1.25	31-41	42-55.6
	8.8		51-59	69.1-79.9		55-68	75.9-92.1
	10.9		57-66	77.2-89.4		62-75	84-101.6
M14	5.6	2.0	49-56	66.4-75.9	1.5	52-64	70.5-86.7
	8.8		81-93	109.8-126		90-106	122-143.6
	10.9		96-109	130.1-147.7		107-124	145-168
M16	5.6	2.0	67-77	90.8-104.3	1.5	69-83	93.6-112.5
	8.8		116-130	157.2-176.2		120-138	162.6-187
	10.9		129-145	174.8-196.5		140-158	189.7-214.1
M18	5.6	2.0	88-100	119.2-136	1.5	100-117	136-158.5
	8.8		150-168	203.3-227.6		177-199	239.8-269.6
	10.9		175-194	237.1-262.9		202-231	273.7-313
M20	5.6	2.5	108-130	146.3-176.2	1.5	132-150	178.9-203.3
	8.8		186-205	252-277.8		206-242	279.1-327.9
	10.9		213-249	288.6-337.4		246-289	333.3-391.6