

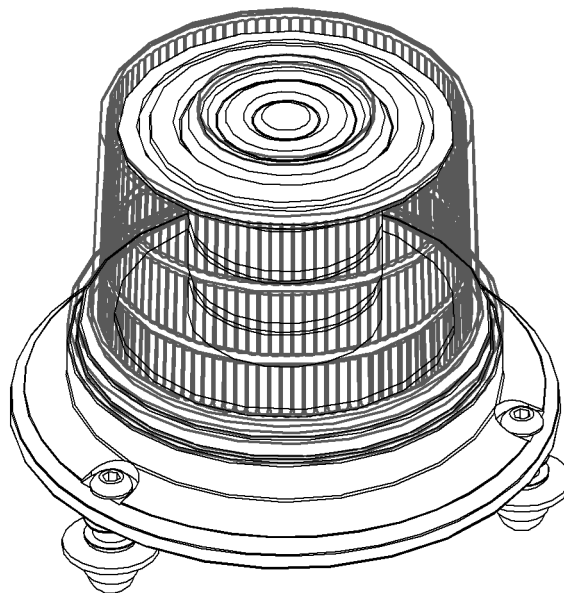

**CLUB CAR CARRYALL
BEACON LIGHT (blue)
p/n: SVP16035001**



Requires:

Carryall 4x2 models 300, 500, 550, or 700:

Overhead Console Kit (47587420001)

Carryall 4x4 models 1500, XRT 1550, 1700, or XRT 1550 SE:

Overhead Console Kit (47617522001)

Approximate Installation Time *

Experienced Dealer Technician – 30 Minutes

Average Dealer Technician – 45 Minutes

Do-It-Yourself – 1 hour

(*=Not including accessories)

The contents of this envelope are the property of the owner. Leave with the owner when installation is complete.

Rev. A, 01/10/2023

p/n: IM-SVP16035001

WARNINGS, TIPS, & REQUIRED TOOLS

For accurate installation, proper operation, and years of satisfaction, please read and understand the installation and owner's manual fully prior to installing the beacon light.

From all of us at Curtis, we thank you for choosing our product.

TOOLS REQUIRED:

- 5/32" and 3/16" Allen wrench or driver
- 7/16" open-end wrench or socket
- Silicone sealant
- Wire cutters (for wire ties)
- Electrical tape
- 3/8" and 7/16" drill bits

INSTALLATION

CARRYALL 4x2:

1. Vehicle Preparation:

- 1.1 Remove the plastic roof from the metal roof pan by removing the 6 button head bolts, metal fender washers and rubber fender washers, keep this hardware for reuse. See figure 1.1.

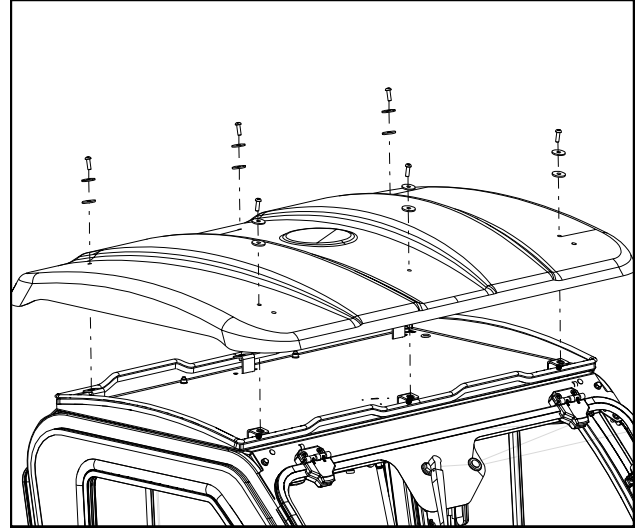

Fig. 1.1

2. Beacon Light Installation:

- 2.1 Use the template included with the Beacon Light to locate and drill 4 holes through the raised platform in the center of the plastic roof. As shown in figure 2.1.

- 2.2 Insert the thicker rubber grommets (AC1033) into the holes drilled into the plastic roof. This will create a weather seal. Silicone sealant is recommended for holes drilled through the roof.

NOTE: The thinner grommets included with this kit are intended for metal roofs and may be discarded.

- 2.3 In the Overhead Console, cut the wire ties securing the coiled yellow/black wires. Be careful not to cut any of the wires. Feed the wires up through the center-left hole in the inner roof above the console.

NOTE: If overhead console is already installed, lower console before proceeding.

- 2.4 Feed the wire from the beacon light into the central of the four holes and secure the light to the roof by feeding 1/4-20 x 1" button head bolts through the light then the rubber grommets in the plastic roof and 1/4" x 1" steel washer and secure using 1/4-20 nylon locknut. Torque bolts to 35±5 in-lbs. See figure 2.4.
- 2.5 Add silicone sealant to wire notch in base of strobe light for maximum weather protection.
- 2.6 Connect the yellow/black wires to the beacon light.
- 2.7 If finished installing accessories, reinstall roof and overhead console at this time. On the roof bolts, use Loctite Threadlocker Blue 242 and tighten until rubber washers begin to compress.

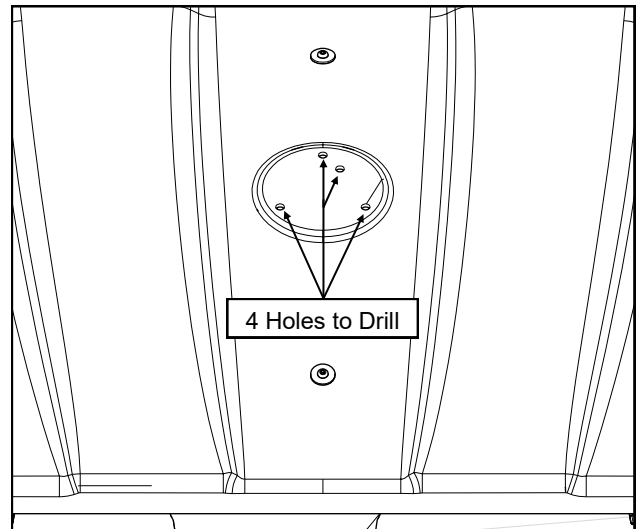

Fig. 2.1

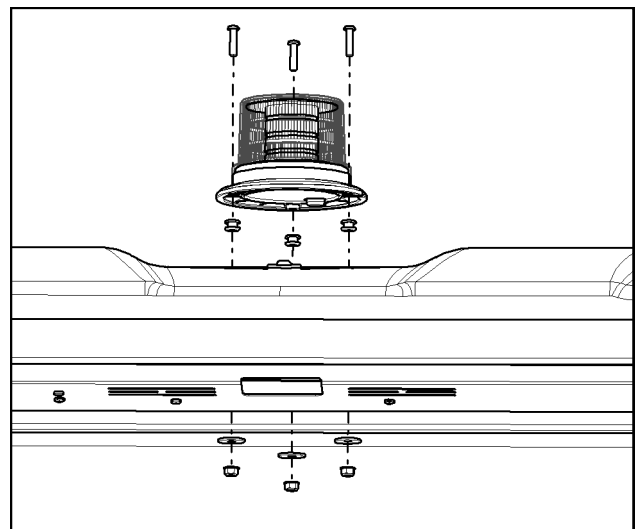

Fig 2.4

INSTALLATION

CARRYALL 4x4:

1. Beacon Light Installation:

1.1 Use the template included with the Beacon Light to locate and drill 4 holes with the template centered side-to-side, front-to-back as listed below and oriented as shown.

1.1a 2-passenger: 21" from roof front edge.

1.1b 4-Passenger: 7" from front roof rear edge.

NOTE: Starting with smaller pilot holes is recommended to avoid damage to headliner material.

1.2 Insert thinner rubber grommets into the holes drilled into the metal roof. This will create a weather seal. Silicone sealant is recommended for holes drilled through the roof.

NOTE: The thicker grommets included with this kit are intended for plastic roofs and may be discarded.

1.3 Feed the wire from the beacon light into the central of the four holes and secure the light to the roof by feeding 1/4-20 x 1" button head bolts through the light then the rubber grommets in the roof and 1/4" x 1" steel washer and secure using 1/4-20 nylon locknut. See figure 1.3.

1.4 Torque bolts to 35±5 in-lbs. and cap with the plastic nut covers provided.

1.5 Add silicone sealant to wire notch in base of strobe light for maximum weather protection.

2. Beacon Light Wiring:

2.1 In the Overhead Console, cut the wire ties securing the coiled yellow/black wires. Be careful not to cut any of the wires.

NOTE: If overhead console is already installed, lower console before proceeding.

2.2 Route the yellow/black wires above the ROPS bar and connect the wires to the beacon light. Cover the beacon light terminals with the section of 1/2" wire loom provided and secure with electrical tape.

2.2 If finished installing accessories, ensure the beacon light wires are routed through the notch in the upper center of the console and install the console to the cab.

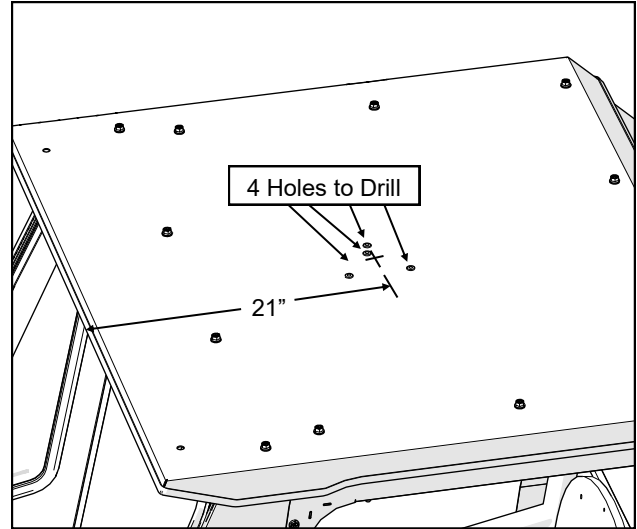

Fig. 1.1a

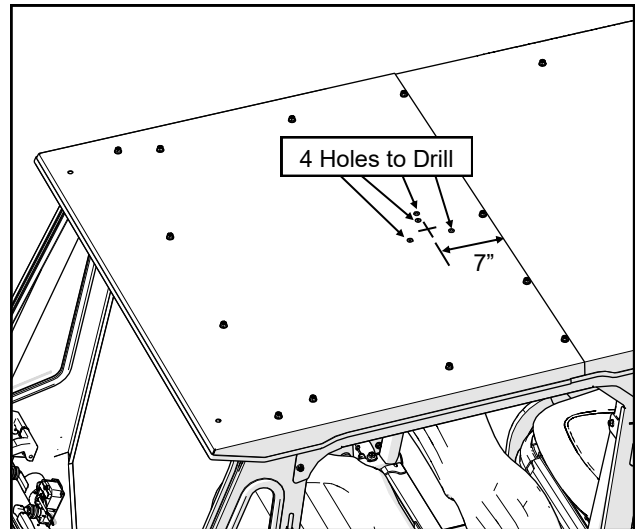

Fig. 1.1b

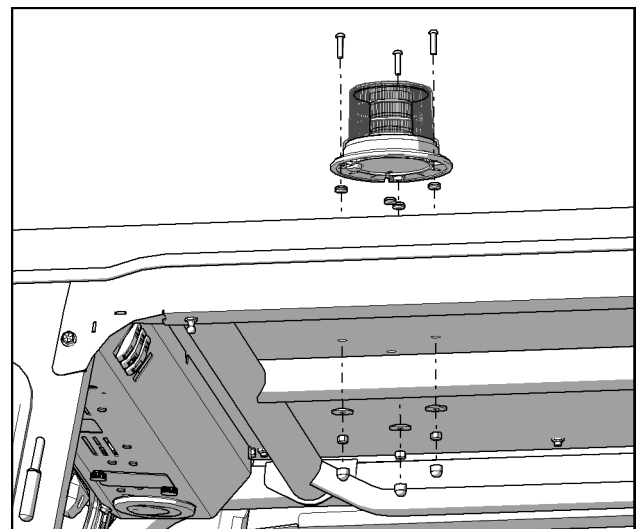

Fig 1.3

BEACON LIGHT DRILL TEMPLATE

A: Three $\frac{7}{16}$ " diameter beacon light mounting holes. Drill at all three marks labeled "A".

B: One $\frac{3}{8}$ " diameter hole for beacon light wire. Choose one best fit location for the wire and drill one hole there (at only one of the options marked "B").

Print or copy at 100% scale (full, 1:1, actual size). Verify the $2\frac{15}{16}$ " dim. and/or the $5\frac{3}{32}$ " dim. to ensure that the template has printed out full scale before using it to drill holes.

