

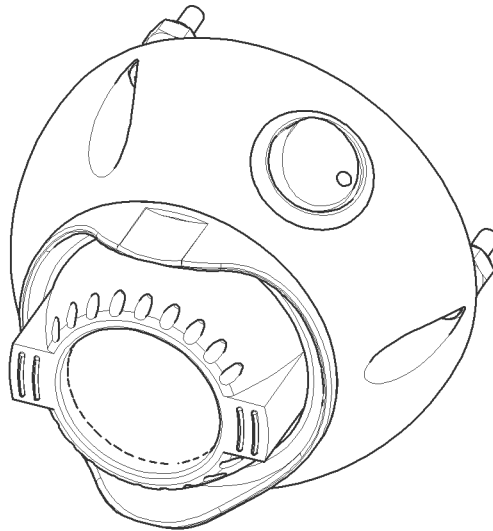

**CLUB CAR CARRYALL
DOME LIGHT
p/n: 47587421001**



Requires:

Carryall 4x2 models 300, 500 550 and 700:
Overheard Console Kit (47587420001)

Carryall 4x4 models 1500, XRT 1550, 1700 and XRT 1550 SE:
Overhead Console Kit (47617522001)

Approximate Installation Time *
Experienced Dealer Technician – 15 Minutes
Average Dealer Technician – 30 Minutes
Do-It-Yourself – 45 Minutes

Approximate Product Specifications

(*=Not including accessories)

The contents of this envelope are the property of the owner. Leave with the owner when installation is complete.

WARNINGS, TIPS, & REQUIRED TOOLS

For accurate installation, proper operation, and years of satisfaction, please read and understand the installation and owner's manual fully prior to installing the dome light.

From all of us at Curtis, we thank you for choosing our product.



NOTICE

Curtis Cabs, blades and general accessories add additional weight to the base vehicle. All Curtis accessory weights are listed in product brochures. Deduct the accessory's total weight from the vehicle's rated capacity and never exceed the vehicle's rated capacity including driver and passenger.



WARNING *Exposure to Carbon Monoxide can Cause illness, serious injury or death. Never operate vehicle if suspicious of Carbon Monoxide. Inspect exhaust system for leaks monthly. Leaks can result from loose connections, corrosion, cracks or other damage to the exhaust manifold. If leaks are found, repair or replace exhaust system. Do not use vehicle until repair or replacement is complete.*

TOOLS REQUIRED:

- #1 (small) Phillips screwdriver
- 5/16" open-end wrench or socket
- 3/16" Allen wrench or driver

CAB INSTALLATION

CARRYALL 4x2:

1. Vehicle Preparation:

- 1.1 Remove the plastic roof from the metal roof pan by removing the 6 button head bolts, metal fender washers and rubber fender washers keep this hardware for reuse. See figure 1.1.

2. Dome Light Installation:

- 2.1 Locate the holes at the center-front of the metal roof pan for the dome light. Poke through the roof headliner from underneath with a small screwdriver or awl. See figure 2.1.
- 2.2 Feed dome light wires through the slotted hole in the roof pan, then secure the light to the pan with the #6-32 x 3/4" pan head screw and #6-32 Nylon locknut supplied. Shown in figure 2.2. Torque to 10 inch-lbs.
- 2.3 Connect orange/black wires to dome light.
- 2.4 If accessory installation is complete, reattach roof at this time. To the roof bolts, apply Loctite Threadlocker Blue 240 and tighten until the rubber washer begins to compress.

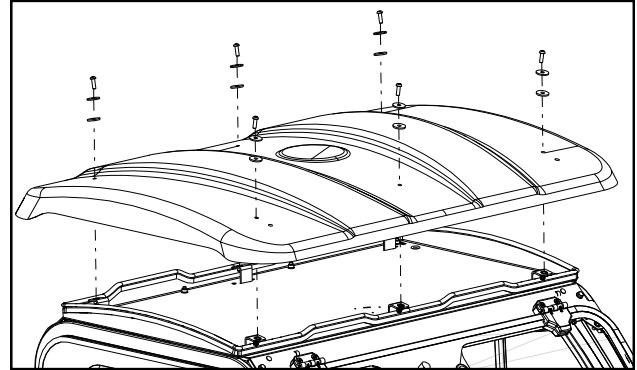

Fig. 1.1

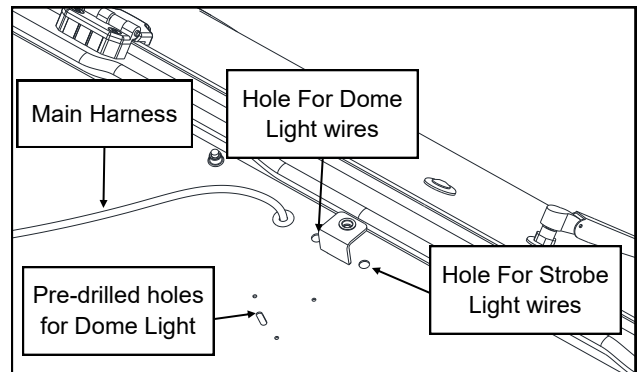

Fig. 2.1

CARRYALL 4x4:

NOTE: If overhead console is already installed, lower console before proceeding.

3. Dome Light Installation:

- 3.1 Push the plastic plug out of the hole in the underside of the overhead console, near the switches.
- 3.2 Feed dome light wires through the larger hole in the console, then secure the light to the pan with the #6-32 x 3/4" pan head screw and #6-32 Nylon locknut supplied. Shown in figure 3.2. Torque to 10 inch-lbs.
- 3.3 Connect orange/black wires to dome light.
- 3.4 Proceed with installation of any additional accessories including the overhead console.

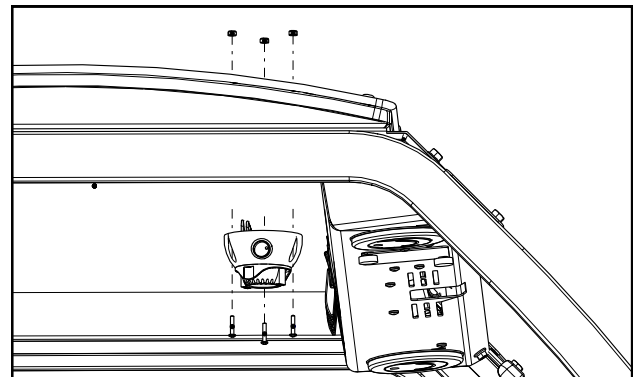

Fig. 2.2

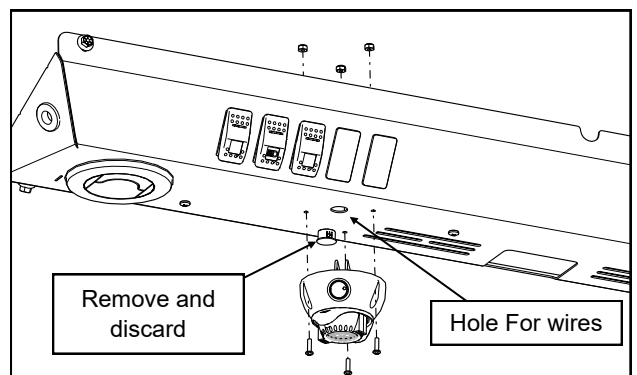

Fig. 3.2