

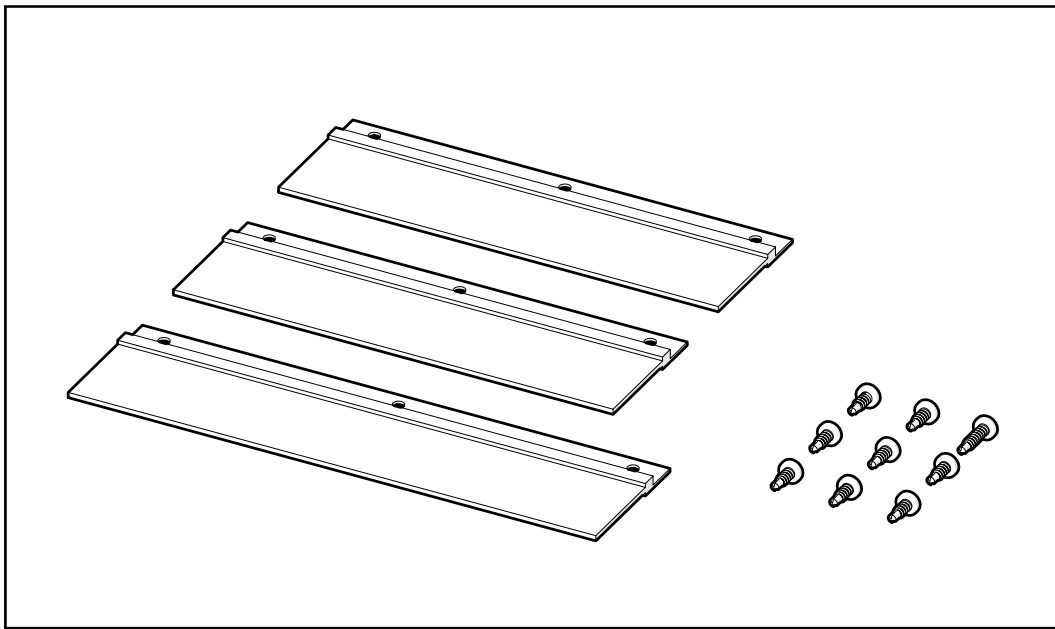

Seal Kit
p/n: 9SK1
fits tractor models:
John Deere 1023E, 1025R, & 2025R



The contents of this envelope are the property of the owner. Leave with the owner when installation is complete.

Rev. B, 06/28/2018

p/n: IM-9SK1

For accurate installation, proper operation, and years of satisfaction, please read and understand the installation and owner's manual fully prior to installing the seal kit.

From all of us at Curtis, we thank you for choosing our product.

California Health and Safety Proposition 65 Warning: This product may contain chemicals known to the state of California to cause cancer and birth defects or other reproductive harm.

TOOLS REQUIRED:

- Drill/Driver
- #2 Phillips Head Bit

STEP 1: LEFT BRUSH

Note: Orient all brushes so the flatter of the two sides mates to the mounting surface.

- 1.1 Locate the one long brush and locate the one long screw. The longer brush will be installed on the left of the cab. The shorter two brushes will be installed on the right of the cab.
- 1.2 Attach the longer brush to the left of the brake pedals with two 1/2" long self-drilling screws through the pre-drilled holes in the left cab floorboard. See Figure 1.2. Secure the rear of the brush to the vehicle floorboard with one 3/4" long self-drilling screw.

Hardware Used	Qty
#10 x 1/2" Pan Head Screw	2
#10 x 3/4" Pan Head Screw	1

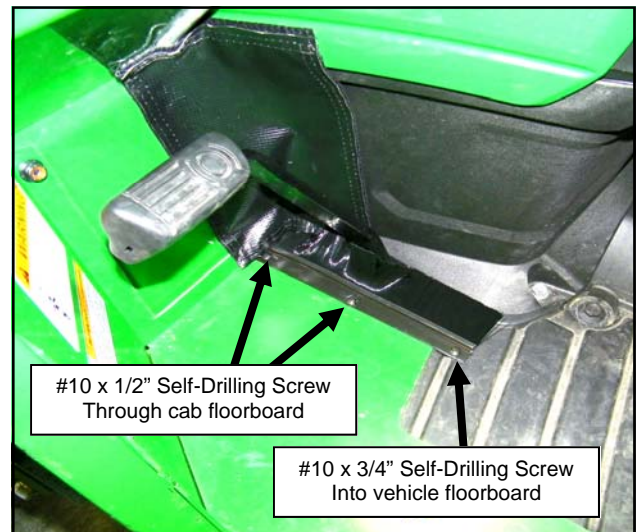

Fig. 1.2 (Attach Brush to Left A-Pillar)

STEP 2: RIGHT BRUSHES

- 2.1 Attach brushes in front and in back of the pedals with the 1/2" long self-drilling screws in the pre-drilled holes in the cab floorboard. See Figure 2.1.

Hardware Used	Qty
#10 x 1/2" Pan Head Screw	6

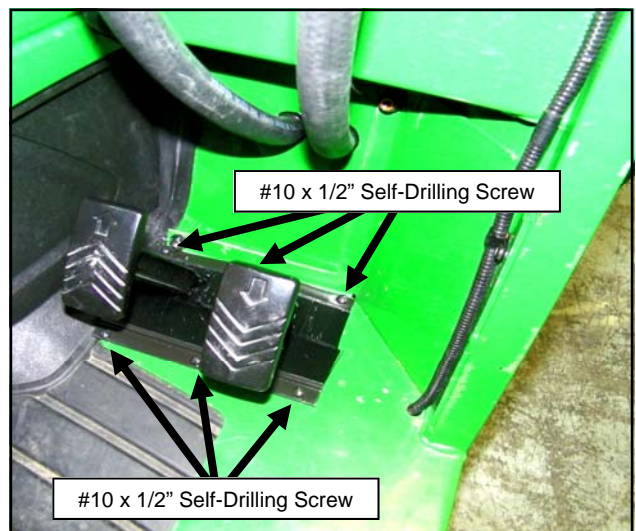

Fig. 2.1 (Attach Brushes to Right Floorboard)