

YAMAHA DRIVE2 GLIDE & RIDE DOOR LATCH REPLACEMENT INSTRUCTIONS

Service Parts:

8SV-9DL08A: DUAL LATCH, ROTARY & SLAM, LEFT
8SV-9DL08B: DUAL LATCH, ROTARY & SLAM, RIGHT

After MFG Code 1533696, an upgraded latch design was implemented on this cab. In order to replace the latch on cabs manufactured before that date, some minor rework to the door frame is required. If your cab has a higher MFG Code than 1533696, rework is not required and you will simply need to replace the latch using the existing hardware (see Step 2).

STEP 1: (REWORK DOOR FRAME)

1.1 Per fig. 1.1, remove and discard the following 7 items from the door handle: two 1/4-20 screws, two 1/4-20 nuts, one M8 bolt, one M8 jam nut, and the entire latch. Note: latch springs, bushings, etc. will come apart when the 1/4-20 screws are removed.

Tools Required:

5/32" Allen Wrench
7/16" Wrench
(2) 13mm Wrenches

1.2 Using a hammer, remove and discard one press fit pin per fig. 1.2. Using a cut-off wheel or jig saw, remove and discard the section of metal tab shown. **Caution:** Protect Plastic components from sparks when using cut-off wheel. Apply paint to newly exposed raw metal as necessary.

Tools Required:

Hammer
Cut-off Wheel or Jig Saw

STEP 2: (INSTALL NEW LATCH)

2.1 By hand, install new M8 Jam Nut and longer M8 Hex Head Bolt into exterior door handle (see fig 2.1), do not tighten with tools. Next, install new latch using new 1/4-20 Button Head Screws and lock nuts provided. Adjust the M8 Hex Bolt until the face of the bolt just touches the activation tab on the latch. Depress the latch pawl with screw driver until it latches. Check to see if exterior door handle properly releases the new latch. Make any further adjustments and tighten down the M8 jam nut.

Tools Required:

5/32" Allen Wrench
7/16" Wrench
Screw Driver
(2) 13mm Wrenches

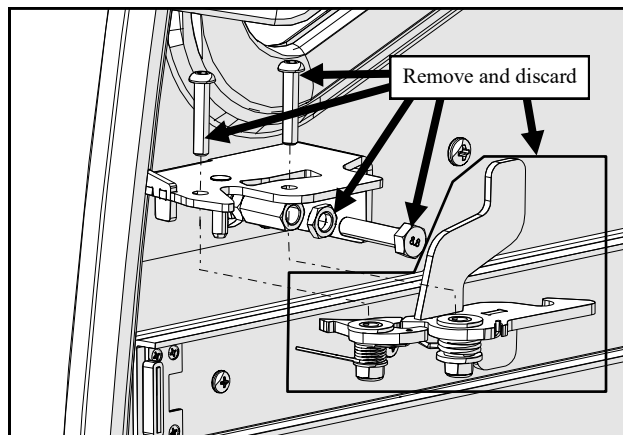

Fig. 1.1 (remove existing latch components - right side)

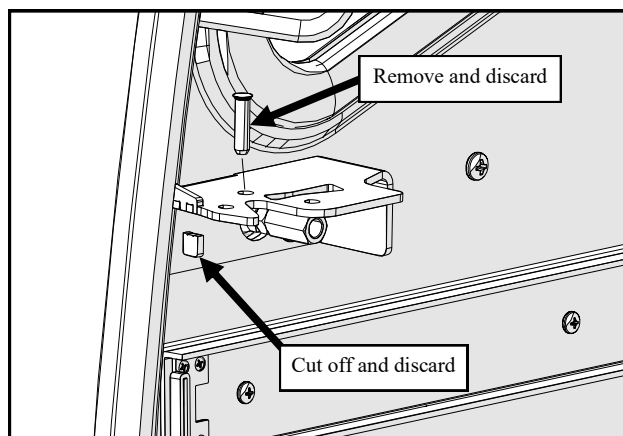

Fig. 1.2 (if necessary, rework latch bracket - right side)

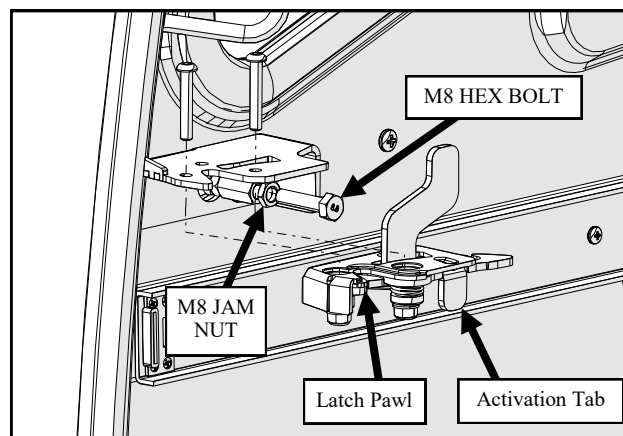

Fig. 2.1 (install new latch - right side)

STEP 3: (DOOR ADJUSTMENT)

3.1 Per figure 3.1a, check to see if there are any gaps between the door contour rubber and side frame contour tube. If necessary, adjust the U-Bolt forward until the rubber is fully sealed (see fig. 3.1b for the forward direction of the U-Bolt).

Tools Required:

(2) 9/16" Wrenches

3.2 If the door does not latch consistently in the closed position, adjust the U-Bolt backwards (see fig. 3.1b for the backward direction of the U-Bolt).

Tools Required:

(2) 9/16" Wrenches

3.3 Check for gaps on the front edge of the door seal. If there is a gap, adjust the U-Bolt inwards (see fig. 3.3 for the inward direction of the U-Bolt). Make sure you are able to close and latch the door without significant force. If you have difficulty latching the door, adjust the U-Bolt outwards (see fig. 3.3 for the outward direction of the U-Bolt).

Tools Required:

(2) 9/16" Wrenches

Installation of the new door latch is complete.

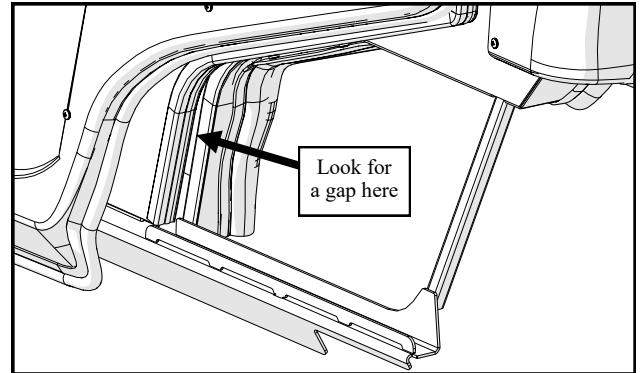

Fig. 3.1a (door contour gap - left side)

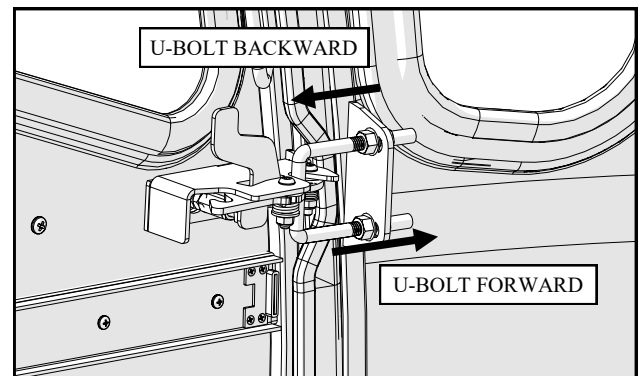

Fig. 3.1b (U-Bolt adjustment - left side)

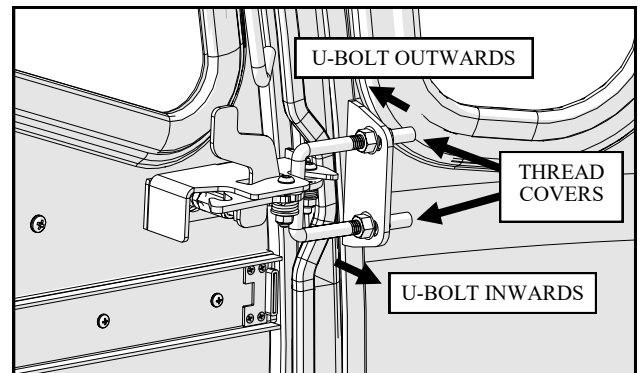

Fig. 3.3 (U-Bolt adjustment - left side)

Service Part:

8SV-YDR2GRDLHK

Door Latch Hardware Kit (contains ten M8 screws and nuts)