

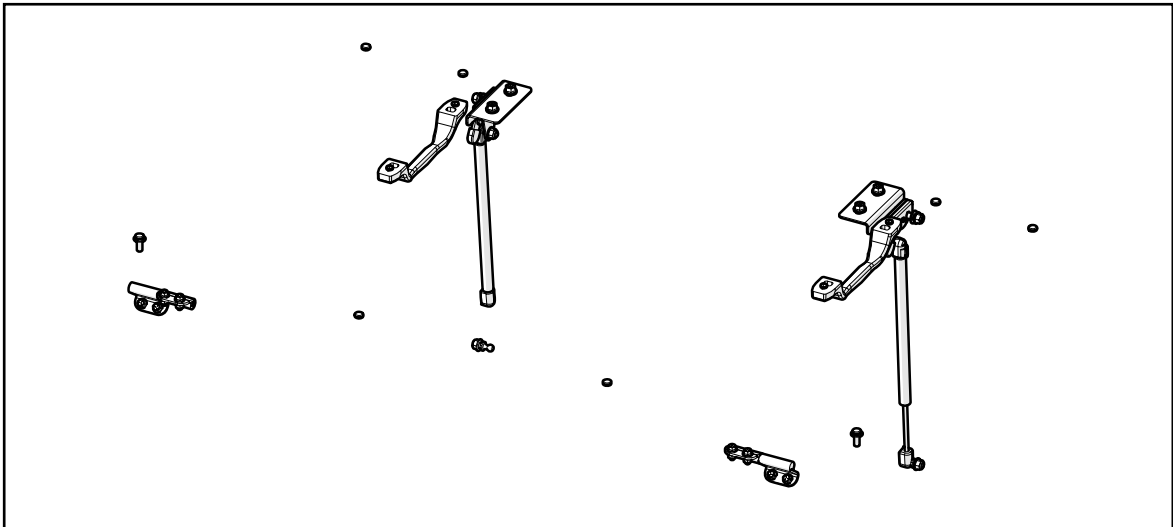

**Yanmar SA Series
Backhoe Compatible Adapter Kit
(p/n: 1YANSAPRBK)
fits tractor models: SA 221, SA 324, SA 424,
SA 325 and SA 425**

While this kit was designed to fit on the vehicle(s) listed above, manufacturing tolerances and vehicle assembly may affect fitment. It is the responsibility of the installer to check all vehicle pedals and levers for full functionality and, as required, adjust the fitment to prevent any interference of components with the travel of pedals or levers.



This kit must be installed with the Yanmar SA Series Premium Cab (P/N: 1YANSAPR).

Approximate Installation Time *
Experienced Dealer Technician – 30 minutes
Average Dealer Technician – 45 minutes
Do-It-Yourself – 1 Hour

(* = Not including accessories)

Approximate Product Specifications
Weight: 5 lbs.

The contents of this envelope are the property of the owner. Leave with the owner when installation is complete.

TABLE OF CONTENTS

WARNINGS, TIPS, & REQUIRED TOOLS	3
KIT INSTALLATION	4-7
KIT FEATURES & OPERATION	8
CARE AND MAINTENANCE	9
SERVICE PARTS	10
TORQUE SPECIFICATION TABLES	11-12





WARNINGS, TIPS, & REQUIRED TOOLS

For accurate installation, proper operation, and years of satisfaction, please read and understand the installation and owner's manual fully prior to installing this kit.

From all of us at Curtis, we thank you for choosing our product.

 NOTICE
<p>Curtis Cabs, blades and general accessories add additional weight to the base vehicle. All Curtis accessory weights are listed in product brochures. Deduct the accessory's total weight from the vehicle's rated capacity and never exceed the vehicle's rated capacity including driver and passenger.</p>

Exposure to Carbon Monoxide can Cause illness, serious injury or death. Never operate vehicle if suspicious of Carbon Monoxide. Inspect exhaust system for leaks monthly. Leaks can result from loose connections, corrosion, cracks or other damage to the exhaust manifold. If leaks are found, repair or replace exhaust system. Do not use vehicle until repair or replacement is complete.

 WARNING	
S e r i o u s I n j u r y o r D e a t h	
	This cab enclosure does not provide protection from rollover or other accidents.
	This cab enclosure does not provide protection from flying objects including golf balls.
	This cab enclosure does not provide protection from lightning. When lightning threatens take cover and do not operate vehicle.

California Health and Safety Proposition 65 Warning: This product may contain chemicals known to the state of California to cause cancer and birth defects or other reproductive harm.

GENERAL INFORMATION BEFORE YOU START

HELPFUL HINTS:

- To assist with this kit's installation, leave all fasteners loose for later adjustment unless otherwise specified.
- Read and understand all instructions before beginning.
- Apply a silicone sealant to seal any minor gaps that may occur due to vehicle variations.
- Before installing parts with factory installed rubber, make sure the rubber is fully installed onto the parts for proper fit and sealing.

TOOLS REQUIRED:

- Set of Standard Sockets (3/8" Drive)
- 3/8" Drive Ratchet
- Torque Wrench
- Set of Standard Wrenches
- Allen Wrenches
- #2 and #3 Phillips Head Screwdrivers
- Flat Head Screw Driver
- Non-Marring Pick
- (2) Quick Grip Clamps
- Drill/Driver
- #2 and #3 Phillips Head Bit
- Tape Measure

KIT INSTALLATION

STEP 1: (ROOF PREP)

- 1.1 Complete installation steps 1 thru 9 of Yanmar SA Series Cab with Heater (P/N: 1YANSAPR)
- 1.2 Prep the roof for installation by removing the (8) rubber plugs as shown in Figure 1.2.

Tools required

Non-Marring Pick

- 1.3 Install supplied rubber plugs into the holes shown in Figure 1.3.
- 1.4 Mount the pre-assembled left latch bracket assembly to the left side of the roof as shown in Figure 1.4. *The headliner is hidden in Figure 1.4 for clarity.*

Hardware Used

	<u>Qty</u>
5/16-18 x 3/4" Hex Head Screw	2
5/16" Nylon Sealing Washer	2
5/16-18 Hex Nut	2

Tools required

1/2" Wrench and Socket

- 1.5 Install a handle to the left side of the roof as shown in Figure 1.5. *The headliner is hidden in Figure 1.5 for clarity.*

Hardware Used

	<u>Qty</u>
#10-32 x 5/8" Screw	2
#10 Nylon Sealing Washer	2
#10-32 Hex Nut	2
Handle Nut Covers	2

Tools required

#2 Phillips Head Screwdriver
3/8" Wrench

- 1.6 Repeat steps 1.4 and 1.5 on the right side of the roof.

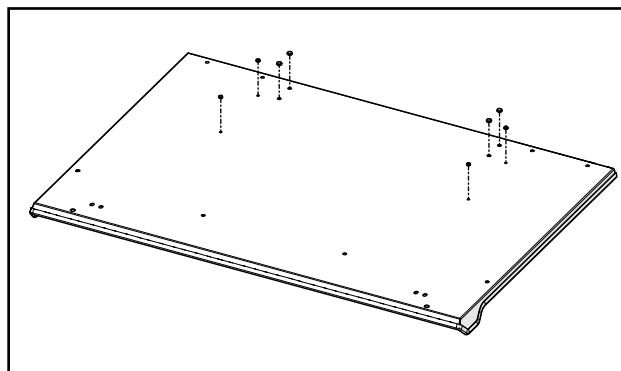

Fig. 1.2 (Remove Rubber Roof Plugs)

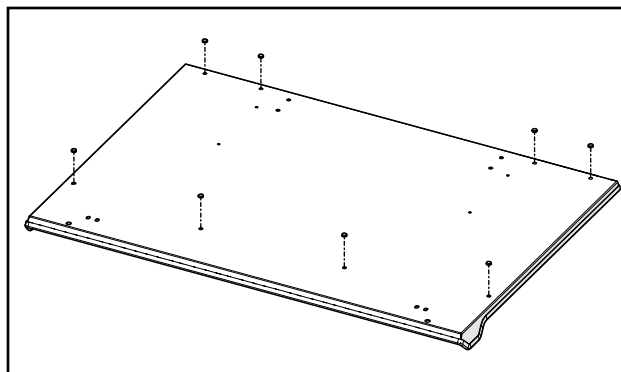

Fig. 1.3 (Install Rubber Roof Plugs)

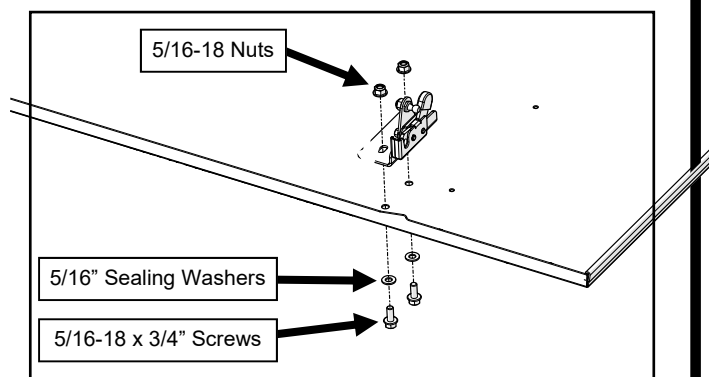

Fig. 1.4 (Latch Bracket Fastening)

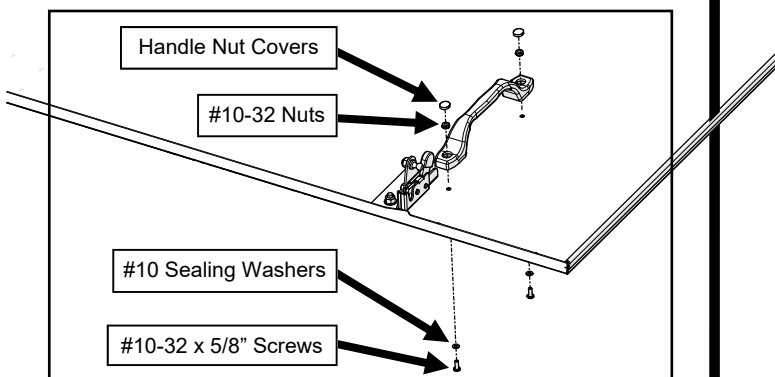

Fig. 1.5 (Roof Handle)

KIT INSTALLATION

STEP 2: (HINGE PINS)

- 2.1 Loosely install the left and right hinge pins to the windshield support as shown in Figures 2.1a and b.

Hardware Used

1/4-20 x 3/4" Hex Head Screw	Qty 4
1/4-20 Hex Nut	4

Tools required

7/16" Wrench or Socket
3/8" Wrench or Socket

- 2.2 Apply a thin layer of grease to the previously installed pins.
- 2.3 Install the hinge sleeves onto the greased hinge pins, as shown in Figures 2.3a and b.

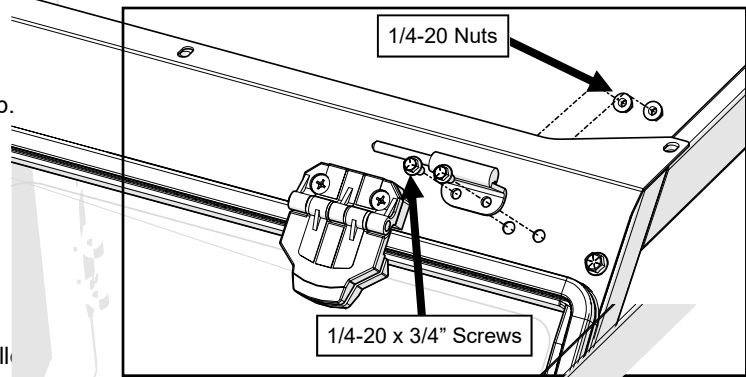

Fig. 2.1a (Left Hinge Pin Orientation)

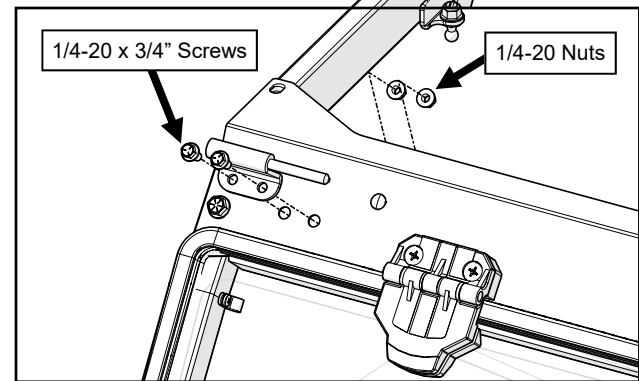

Fig. 2.1b (Right Hinge Pin Orientation)

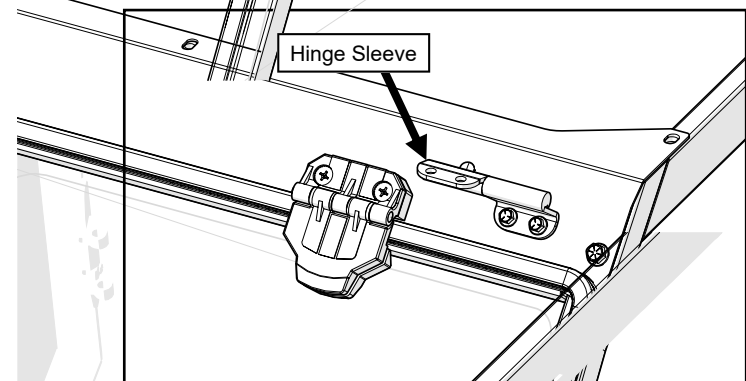

Fig. 2.3a (Left Hinge Sleeve Orientation)

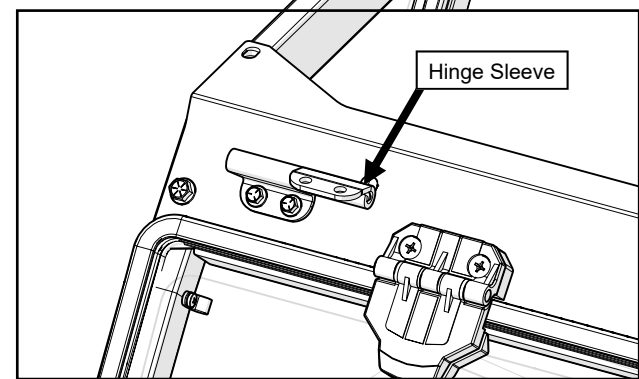

Fig. 2.3b (Right Hinge Sleeve Orientation)

KIT INSTALLATION

STEP 3: (SIDE FRAME PREP)

- 3.1** Remove previously installed top screw and nut in the left rear leg assembly and install a latch striker pin, washer, and nut as shown in Figure 3.1.

Hardware Used

5/16-18 Shoulder Bolt	<u>Qty</u>
5/16" Washer	1
5/16-18 Hex Nut	1

Tools required

3/16" Allen Wrench
1/2" Wrench and Socket

- 3.2** Remove previously installed second-to-top screw and nut in the left rear leg assembly and install a ball stud as shown in Figure 3.1.

Hardware Used

Ball Stud	<u>Qty</u>
5/16-18 Hex Nut	1

Tools required

1/2" Wrench and Socket

- 3.3** Repeat steps 3.1 and 3.2 on the right side of vehicle.

- 3.4** Fasten the top flange of the windshield support to the side frame as shown in Figure 3.4.

Hardware Used

5/16-18 x 3/4" lg. Button Head Screw	<u>Qty</u>
	2

Tools required

3/16" Allen Wrench

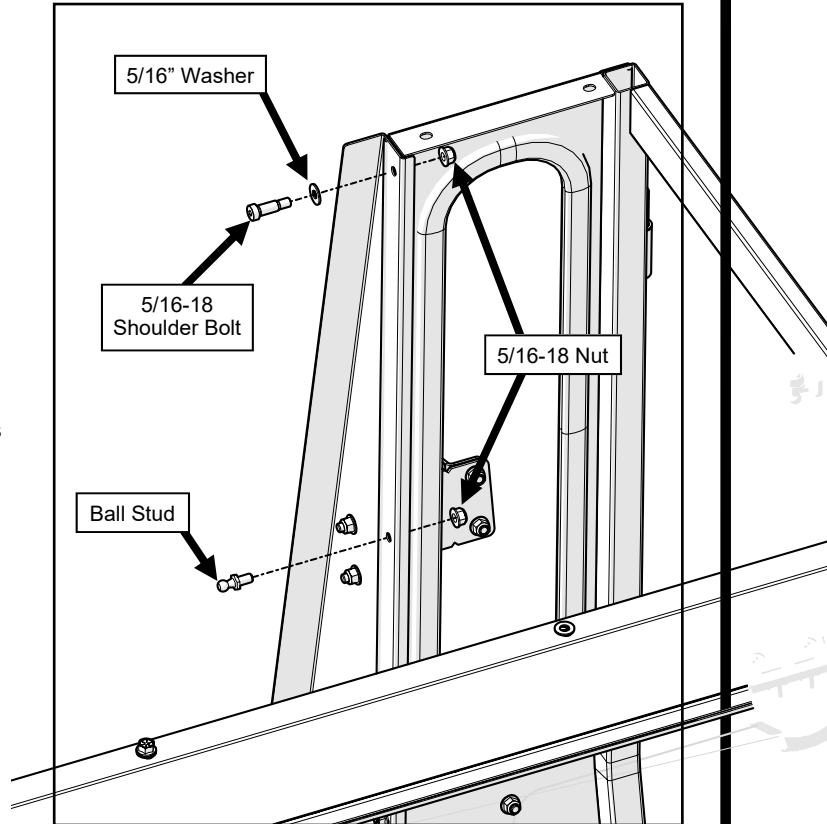
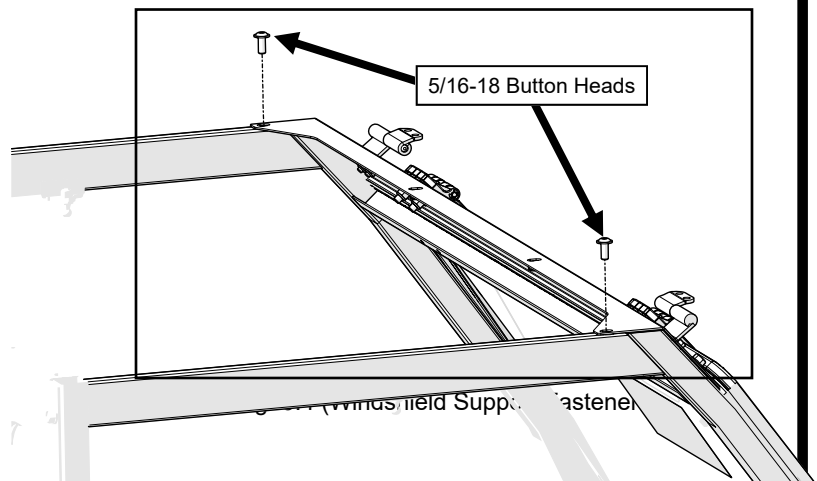

Fig. 3.1 (Install Striker Pin and Ball Stud)



KIT INSTALLATION

STEP 4: (ROOF)

- 4.1 With assistance, set the roof on top of the cab.
- 4.2 Once the roof is resting on the side frames, push the roof forward so the inside of the roof's rear flange is tight up against the outboard surface of the rear legs, then center roof side to side. See Figure 4.2.
- 4.3 Loosely fasten the hinge sleeves to the roof as shown in Figure 4.3.

Hardware Used

	Qty
1/4-20 X 3/4" Hex Head Screw	4
1/4" Nylon Sealing Washer	4
1/4-20 Lock Nut	4

Tools required

7/16" Wrench or Socket
3/8" Wrench or Socket

- 4.4 Measure the width of the rear legs (outside to outside). Adjust the width if needed to 24-7/8". Measure opening corner to corner for squareness and clamp the rear flange of the roof to each of the rear legs. See Figure 4.4.

Tools required

(2) Quick Grip Clamps
Tape Measure

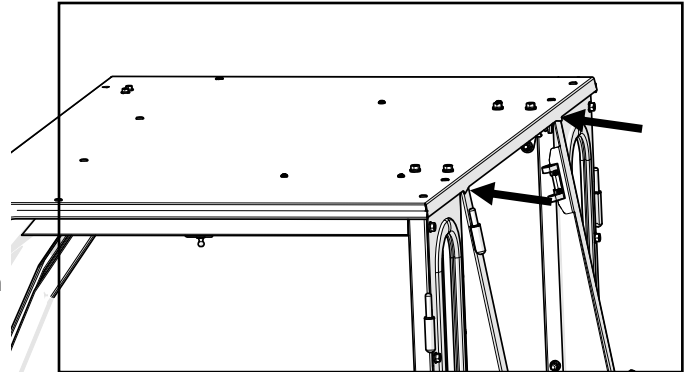

Fig. 4.2 (Positioning Roof against Rear Legs)

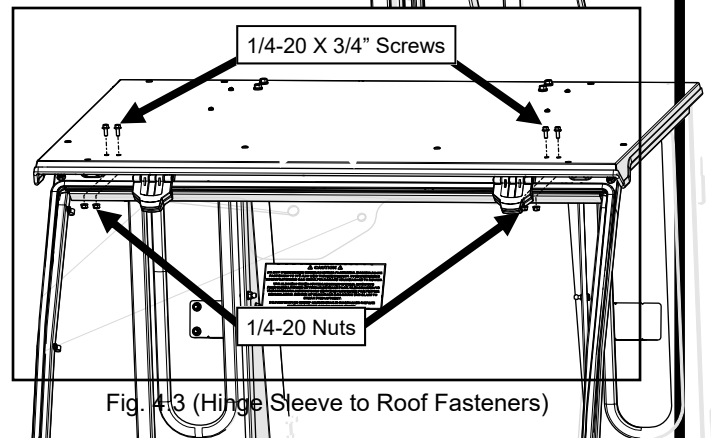

Fig. 4.3 (Hinge Sleeve to Roof Fasteners)

STEP 5: (COMPLETE INSTALL)

- 5.1 Continue with the cab installation picking back up at step 11 of the cab manual.
- 5.2 Tighten the roof hinge fasteners. See torque tables on pages 11 and 12 of this manual.

Tools required

7/16" Wrench and Socket
3/8" Wrench and Socket
Torque Wrench

- 5.3 Have an assistant open and hold the roof up. See Figure 5.3. Attach a gas strut to the ball studs on the side frame and roof. Make sure the quick release end is on the roof to ensure the strut seal stays lubricated.

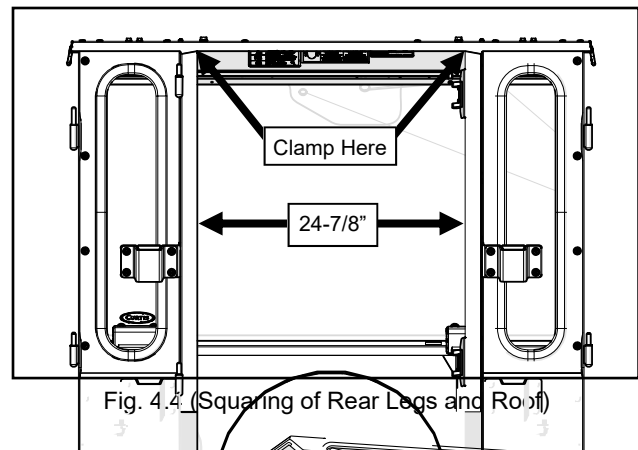

Fig. 4.4 (Squaring of Rear Legs and Roof)

STEP 6: (FINISHING TOUCHES)

- 6.1 Due to the nature of the packaging materials used for shipping this product, the components of the cab system may have dust on their surfaces upon removal from the packaging. It is recommended that after completion of the cab installation, the cab and vehicle are washed thoroughly to eliminate any dust or contaminants. See the Care and Maintenance section on page 9 of this manual for critical information on cleaning the cab.

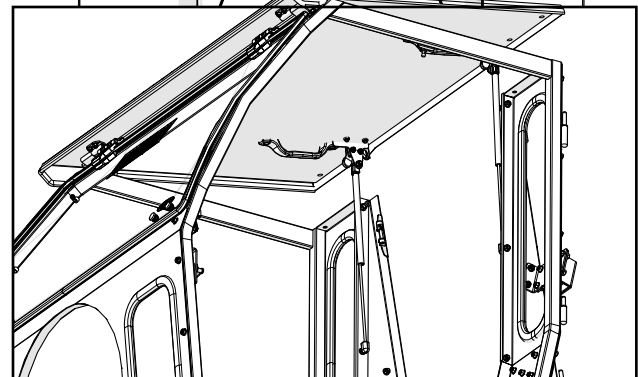

Fig. 5.3 (Gas Strut Orientation)

KIT FEATURES & OPERATION

POP-UP ROOF

Your SA Series enclosure is now equipped with a pop-up roof which enables the operation of the backhoe along with adding additional ventilation. Prior to popping up the roof, open both of the rear window latches placing the rear window in the venting position. To open the roof, simply grasp the handles and then activate the roof latches with your thumbs. The roof will raise automatically on the gas struts. To close, simply pull down on both roof handles until the latches are engaged on the frame-mounted striker pins. Once the roof is closed, the rear window may be closed if desired.

Note: Two soft audible clicks should be heard from each latch indicating that the roof is fully closed.

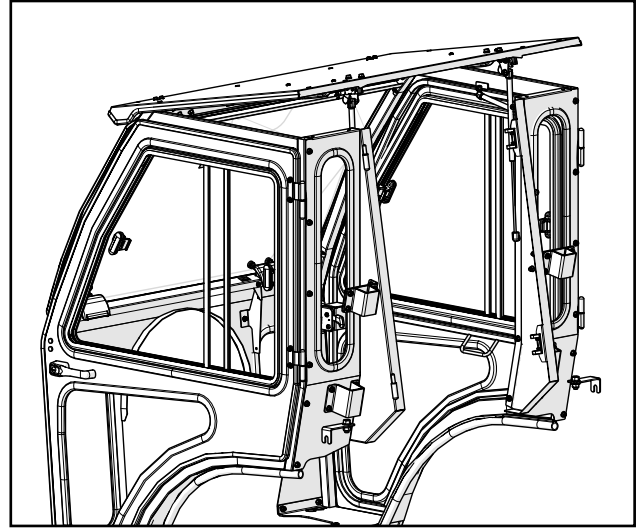

Pop-Up Roof

CARE AND MAINTENANCE

- Re-apply lubrication (preferably grease) periodically as needed to the hinge pins and latch assemblies.
- Check and tighten hardware after 40 hours of operation. Periodically inspect and tighten hardware for the remainder of the unit's life.
- Wash the painted surfaces of the this kit with commercial automotive cleaning products.

SERVICE PARTS

PART NUMBER	DESCRIPTION
9SV-HRR1	ROOF HINGE KIT #1 (INCL. 1 SET OF L & R W/SLEEVE)
9SV-GH	GRAB HANDLE KIT (SET OF 2)
9SV-RFL	ROOF LATCH KIT (INCL. L & R)
9SV-GS02A	BALL STUDS, 10MM (BAG OF 10)
9SV-GS10Q	GAS SPRINGS, 20" EXT, QUICK DISCONNECT ENDS (SET OF 2)
8SV-SM-02078	ROOF LATCH MOUNT SET (L&R)

Tightening of Non-Structural Bolts

For light or medium duty fastening, Curtis recommends using a general industry standard of tightening until snug and then giving an additional one quarter turn of the tool as deemed reasonable for the application (i.e.: at the installer's discretion).

If torque values are required, the examples listed below are intended as a reasonable reference for use in the majority of non-structural fastener applications such as: small diameter fasteners; bolts passing thru tubing, glass, plastic, nylon or rubber washers, threaded inserts, etc.

If more than one application below applies, use the lower torque value.



FASTENER SIZE:	FASTENER TYPE:	WASHER MATERIAL:	APPLICATION:	TORQUE (INCH-POUNDS) (±5)
#10	Machine Screws	-	in Nylon P-Clamps	20
#10	Machine Screws	-	Strobe Light (plastic base)	35
M5	Set Screws	-	Wiper Arm	20
1/4"	Cap Nut	-	Windshield Wiper	20
1/4"	Bolts	-	Tubing (5/8" to 3/4" wide)	132
1/4"	Bolts	Rubber	-	60
1/4"	Bolts	Nylon / Plastic	-	72
1/4"	Bolts	-	Factory Installed Threaded Inserts	132
5/16"	Bolts	-	Tubing (1" or wider)	60
5/16"	Flat Head Bolts	-	Plastic Windshield Hinge	79
5/16"	Bolts	Rubber	-	120
5/16"	Bolts	Nylon / Plastic	-	150
5/16"	Ball Studs	-	-	150
5/16"	Bolts	-	Factory Installed Threaded Inserts	240
3/8"	Bolts	-	Tubing	120
M12	Door Striker Pins	-	-	120

Torque Specs. for Structural Bolts

This page is for use primarily when dealing with high-strength vehicle fasteners such as ROPS hardware that hold the structure together for safety. This page can also be used for other solid metal-to-metal joints. **Do not** use these high torque values on any of the following applications involving: tubing, plastic, nylon or rubber washers, threaded inserts, etc.. See previous page regarding less critical fasteners.

The values below apply to fasteners that are dry or lubricated with normal engine oil. They do not apply if special graphited or moly disulphide greases or other extreme pressure lubricants are used. This applies to both UNF and UNC threads. Remember to always use the same grade or property class when replacing bolts.

IMPORTANT: on all PLATED GRADE 8 bolts, reduce torque 15% from listed bolt torque specification.

SAE Grade No.		2				5				8*				
Bolt head identification mark as per grade. NOTE: Manufacturing Marks Will Vary														
		TORQUE		TORQUE		TORQUE		TORQUE		TORQUE		TORQUE		
Bolt Size	Inches	Millimeters	Pounds Feet		Newton-Meters		Pounds Feet		Newton-Meters		Pounds Feet		Newton-Meters	
			Min.	Max.	Min.	Max.	Min.	Max.	Min.	Max.	Min.	Max.	Min.	Max.
1/4	6.35		5	6	7	8	9	11	12	15	12	15	16	20
5/16	7.94		10	12	14	16	17	20.5	23	28	24	29	33	39
3/8	9.53		20	23	27	31	35	42	48	57	45	54	61	73
7/16	11.11		30	35	41	47	54	64	73	87	70	84	95	114
1/2	12.70		45	52	61	70	80	96	109	130	110	132	149	179
9/16	14.29		65	75	88	102	110	132	149	179	160	192	217	260
5/8	15.88		95	105	129	142	150	180	203	244	220	264	298	358
3/4	19.05		150	185	203	251	270	324	366	439	380	456	515	618
7/8	22.23		160	200	217	271	400	480	542	651	600	720	814	976
1	25.40		250	300	339	406	580	696	787	944	900	1080	1220	1464
1-1/8	25.58		-	-	-	-	800	880	1085	1193	1280	1440	1736	1953
1-1/4	31.75		-	-	-	-	1120	1240	1519	1681	1820	2000	2468	2712
1-3/8	34.93		-	-	-	-	1460	1680	1980	2278	2380	2720	3227	3688
1-1/2	38.10		-	-	-	-	1940	2200	2631	2983	3160	3560	4285	4827

*Thick Nuts must be used with Grade 8 bolts

METRIC BOLT TORQUE SPECIFICATIONS



Size of Screw	Property Class	Course Thread			Fine Thread		
		Pitch (mm)	Pounds Feet	Newton-Meters	Pitch (mm)	Pounds Feet	Newton-Meters
M6	5.6	1.0	3.6-5.8	4.9-7.9	-	-	-
	8.8		5.8-9.4	7.9-12.7		-	-
	10.9		7.2-10	9.8-13.6		-	-
M8	5.6	1.25	7.2-14	9.8-19	1.0	12-17	16.3-23
	8.8		17-22	23-29.8		19-27	25.7-36.6
	10.9		20-26	27.1-35.2		22-31	29.8-42
M10	5.6	1.5	20-25	27.1-33.9	1.25	20-29	27.1-39.3
	8.8		34-40	46.1-54.2		35-47	47.4-63.7
	10.9		38-46	51.5-62.3		40-52	54.2-70.5
M12	5.6	1.75	28-34	37.9-46.1	1.25	31-41	42-55.6
	8.8		51-59	69.1-79.9		55-68	75.9-92.1
	10.9		57-66	77.2-89.4		62-75	84-101.6
M14	5.6	2.0	49-56	66.4-75.9	1.5	52-64	70.5-86.7
	8.8		81-93	109.8-126		90-106	122-143.6
	10.9		96-109	130.1-147.7		107-124	145-168
M16	5.6	2.0	67-77	90.8-104.3	1.5	69-83	93.6-112.5
	8.8		116-130	157.2-176.2		120-138	162.6-187
	10.9		129-145	174.8-196.5		140-158	189.7-214.1
M18	5.6	2.0	88-100	119.2-136	1.5	100-117	136-158.5
	8.8		150-168	203.3-227.6		177-199	239.8-269.6
	10.9		175-194	237.1-262.9		202-231	273.7-313
M20	5.6	2.5	108-130	146.3-176.2	1.5	132-150	178.9-203.3
	8.8		186-205	252-277.8		206-242	279.1-327.9
	10.9		213-249	288.6-337.4		246-289	333.3-391.6