



POLARIS®

INSTALLATION INSTRUCTIONS POLARIS MODULAR REAR PANEL KIT (p/n 2874888)

IMPORTANT: THIS ACCESSORY WEIGHS 60 POUNDS. PLEASE ADJUST THE VEHICLE PAYLOAD ACCORDINGLY.

The contents of this envelope are the property of the owner. Be sure to leave with the owner when installation is complete.

⚠ WARNING *Exposure to Carbon Monoxide can Cause illness, serious injury or death. Never operate vehicle if suspicious of Carbon Monoxide. Inspect exhaust system for leaks monthly. Leaks can result from loose connections, corrosion, cracks or other damage to the exhaust manifold. If leaks are found, repair or replace exhaust system. Do not use vehicle until repair or replacement is complete.*

⚠ NOTICE
Curtis Cabs, blades and general accessories add additional weight to the base vehicle. All Curtis accessory weights are listed in product brochures. Deduct the accessories total weight from the vehicles rated capacity and never exceed the vehicles rated capacity including driver and passenger.

TOOLS REQUIRED:



3/16" ALLEN WRENCH



OPEN END WRENCHES
(7/16", AND 1/2")



3/8" RATCHET



SOCKETS W/ 3/8" DRIVE
(7/16" AND 1/2")



PHILIPS HEAD
SCREWDRIVER

1. INSTALL REAR PANEL ASSEMBLY

CAUTION: use care to avoid potential pinch points during installation!

- 1.1 Install an 18" long piece of self-adhesive rubber cushion onto each of the two middle tubes at the rear of the vehicle. Install at the outside of the bend (starting just below the middle cross tube) as shown in fig. 1.1. (NOTE: white lines on tube in photo represent placement of both rubber cushions.)
- 1.2 Mount hinge pins to outside of rear panel with the pins on the front side of the bolts (as shown in Fig. 1.2). (NOTE: locknuts to be on the outside.)
- 1.3 Lift the dump bed to full upright position. With assistance, bring the rear panel assembly to one side of the vehicle. Slowly and carefully place the rear panel assembly halfway behind the rear tubular frame. With one person on each side of the vehicle, lift and place it so the top internal bent flange hooks over the top of the rear tubular frame, and the rear side legs are outside the rear vertical tubular frames. Swing bottom forward to seat.

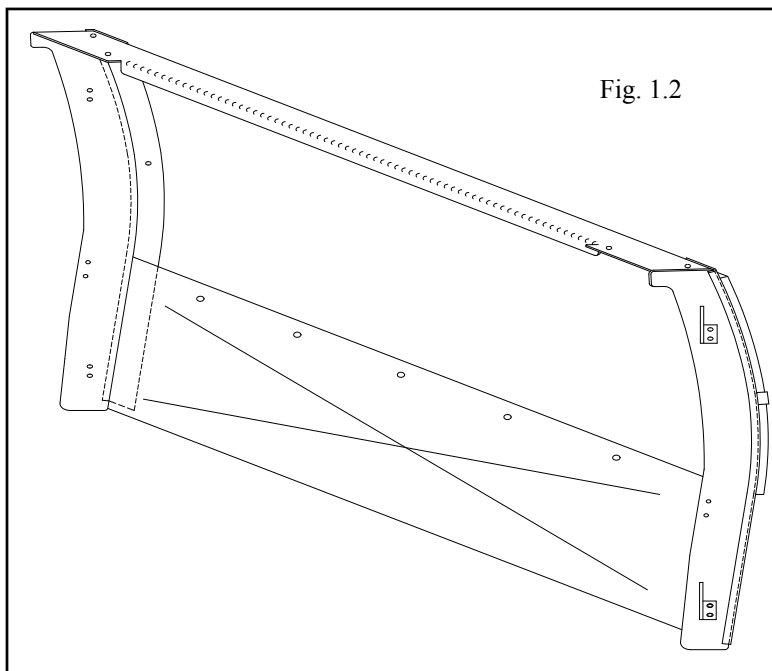

Fig. 1.2



Fig. 1.1

POLARIS MODULAR CAB PARTS LIST
REAR PANEL KIT

<u>REAR PANEL ASSEMBLY</u>	<u>QTY.</u>	<u>P/N</u>
	1	2874888

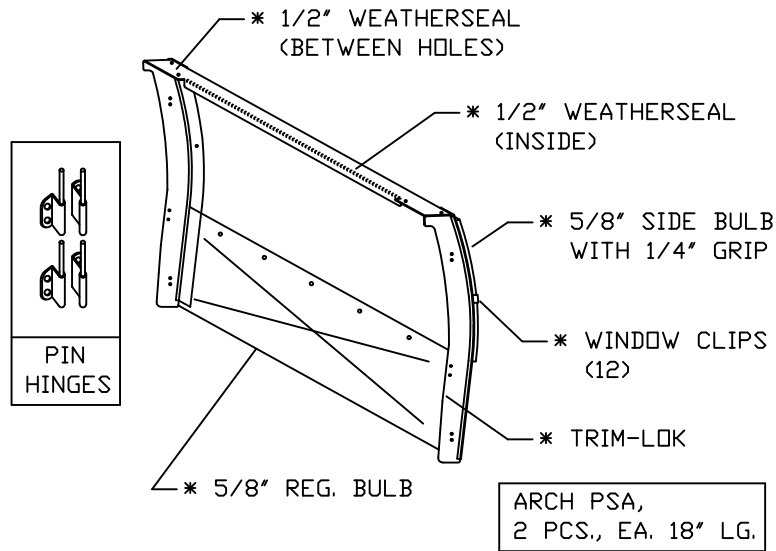

UPPER MOUNTS

<u>QTY.</u>	<u>P/N</u>
2	2874888-2

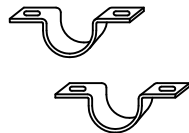



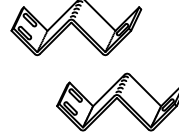

LOWER MOUNTS

<u>QTY.</u>	<u>P/N</u>
2	2874888-3



RUBBER TYPES:

<p>TRIM LOCK</p>  <p>9PR01</p>	<p>5/8" REG. BULB</p>  <p>9PR02</p>	<p>5/8" SIDE BULB W/1/4" GRIP</p>  <p>9PR23</p>	<p>ARCH PSA</p>  <p>9PR09</p>	<p>1/2" WEATHER SEAL</p>  <p>9PR20</p>
---	--	--	---	---

CABS/BLADES/SPREADERS/ACCESSORIES

POLARIS MODULAR CAB PARTS LIST

REAR PANEL KIT

ADDITIONAL SERVICE PARTS

<u>QTY.</u>	<u>P/N</u>	<u>DESCRIPTION</u>
1	2874888-1	REAR PANEL (LEXAN)
12	9WC01	WINDOW CLIPS
2	9PH006A	PIN HINGES (LEFT)
2	9PH005A	PIN HINGES (RIGHT)
2	2874888-2	UPPER MOUNTS
2	2874888-3	LOWER MOUNTS
1	287488-HWK	HINGE HARDWARE (FOR UPPER AND LOWER MOUNTS)
1	287488-HK	HARDWARE BAG #2 (FOR PIN HINGES)

HARDWARE BAG CONTAINS:

- (06) 5/16-18 x 1" LONG BUTTON HEAD SCREWS
- (08) 5/16-18 x 1 1/4" LONG BUTTON HEAD SCREWS
- (10) 3/8" NYLON WASHERS
- (20) 5/16" FLAT STEEL WASHERS
- (10) 5/16-18 LOCKNUTS
- (10) 5/16" PLASTIC NUT COVERS

HINGE HARDWARE CONTAINS:

- (8) 1/4-20 x 5/8" LONG HEX. HEAD BOLTS
- (8) 1/4" FLAT STEEL WASHERS
- (8) 1/4-20 LOCKNUTS