



**Kubota LX Series  
Cab with Heater (p/n: 1KLXPC and 1KLXCA)  
fits tractor models: LX2610SUHSD, LX2610HSD, and  
LX3310HSD.  
Adaptor kit (sold separately) allows cab to fit with backhoe.**

*While this cab kit was designed to fit on the vehicle(s) listed above, manufacturing tolerances and vehicle assembly may affect cab fitment. It is the responsibility of the cab installer to check all vehicle pedals and levers for full functionality and, as required, adjust the cab fitment to prevent any interference of the cab components with the travel of pedals or levers.*



1KLXPC (cab with vinyl hinged doors)



1KLXCA (cab with steel doors)

Available Options:

1. Front LED Work Lights (P/N: 9LEDW4)
2. Rear LED Work Lights (P/N: 9LEDW3)
3. Strobe Light (P/N: 9LEDS2)
4. Dome Light (P/N: 9LEDD14)
5. Side View Mirrors (P/N: 9PM5)
6. Rear View Mirror (P/N: 9PM3)
7. Rear Wiper (P/N: 9PWK8512F9-11A)
8. Adaptor kit for Backhoe (P/N: 1KLXPCBK) Contact Curtis for details

Approximate Installation Time *
Experienced Dealer Technician – 3.5 Hours
Average Dealer Technician – 4.5 Hours
Do-It-Yourself – 5.5 Hours

(\*Including the heater installation)

Approximate Product Specifications
Floorboard to Roof Height: 59.125 inches
Weight: PC Cab 226 lbs., CA Cab 259 lbs.
Cab Width: 44.75 inches

The contents of this envelope are the property of the owner. Leave with the owner when installation is complete.

# TABLE OF CONTENTS

WARNINGS, TIPS, & REQUIRED TOOLS.....	3
CAB INSTALLATION.....	4-26
CAB FEATURES & OPERATION.....	27
CARE AND MAINTENANCE.....	28
SERVICE PARTS .....	29-31
OPTIONAL ACCESSORIES .....	32
TORQUE CHARTS.....	33-34



# WARNINGS, TIPS, & REQUIRED TOOLS

Curtis cabs feature an assembly of parts designed for your vehicle which require adjustment and alignment of components to accommodate vehicle variations and provide proper weather protection. For accurate installation, proper operation, and years of satisfaction, please read and understand the installation and owner's manual fully prior to installing the cab.

From all of us at Curtis, we thank you for choosing our product.

 <b>NOTICE</b>
<p>Curtis Cabs, blades and general accessories add additional weight to the base vehicle. All Curtis accessory weights are listed in product brochures. Deduct the accessory's total weight from the vehicle's rated capacity and never exceed the vehicle's rated capacity including driver and passenger.</p>

<p><b>WARNING</b> Exposure to Carbon Monoxide can Cause illness, serious injury or death. Never operate vehicle if suspicious of Carbon Monoxide. Inspect exhaust system for leaks monthly. Leaks can result from loose connections, corrosion, cracks or other damage to the exhaust manifold. If leaks are found, repair or replace exhaust system. Do not use vehicle until repair or replacement is complete.</p>
---

<b>WARNING</b>	
Serious Injury or Death	
	This cab enclosure does not provide protection from rollover or other accidents.
	This cab enclosure does not provide protection from flying objects including golf balls.
	This cab enclosure does not provide protection from lightning. When lightning threatens take cover and do not operate vehicle.

**California Health and Safety Proposition 65 Warning:** This product may contain chemicals known to the state of California to cause cancer and birth defects or other reproductive harm.

## GENERAL INFORMATION BEFORE YOU START

### HELPFUL HINTS:

- Refer to parts diagram found in the service parts section of this manual to help identify parts during the assembly process.
- To assist with the cab installation, leave all fasteners loose for later adjustment unless otherwise specified.
- Read and understand all instructions before beginning.
- Apply a silicone sealant to seal any minor gaps that may occur due to vehicle variations.
- Use caution to avoid damaging the factory installed threaded inserts or weld nuts. Begin the thread engagement by hand to avoid or correct potential cross threading.
- Make sure the areas where the supplied self-adhesive hook Velcro and seals will be applied are clean, dry, and at room temperature for best adhesion.
- Before installing parts with factory installed rubber, make sure the rubber is fully installed onto the parts for proper fit and sealing.
- Plastic washers have been supplied to provide a weather seal under the heads of some exterior bolts. The plastic washer should be installed under each bolt head directly against the outside cab surface. Care should be taken not to over tighten the fasteners and damage the plastic washer.

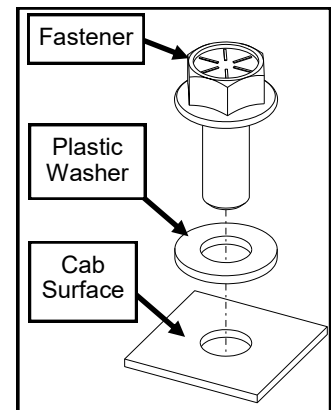

### TOOLS REQUIRED:

- Set of Standard and Metric Sockets including deep sockets (3/8" Drive)
- 3/8" Drive Ratchet with extension
- Torque Wrench
- Set of Standard and Metric Open-End Wrenches
- Set of Standard and Metric Allen Wrenches
- #2 and #3 Phillips Head Screwdrivers
- Drill/Driver
- #2 and #3 Phillips Head Bit
- Utility Knife
- Pair of Scissors
- Shears
- Grease
- Silicone Sealant
- Teflon Tape
- Tape Measure

# CAB INSTALLATION

## STEP 1: (VEHICLE PREP)

- 1.1 Disconnect the negative battery cable.
- 1.2 If equipped, remove and set aside the SMV sign.
- 1.3 Pull up the edges of the floor mat to reveal the rubber plugs that hold it down. See Figure 1.3.
- 1.4 Punch a 5/8" hole in the floor mat to remove the rubber plug. See Figure 1.4.
- 1.5 Repeat step 1.4 for the rubber plugs marked in Figures 1.5a and 1.5b.

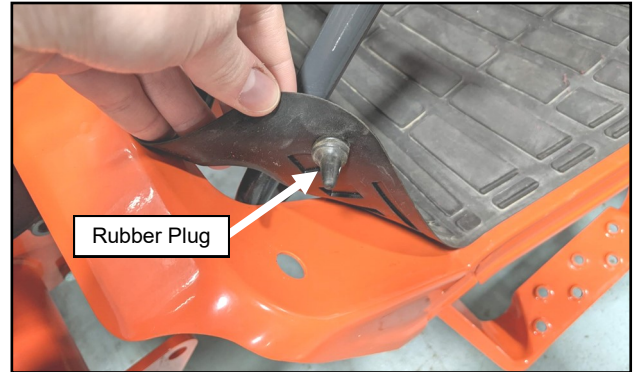
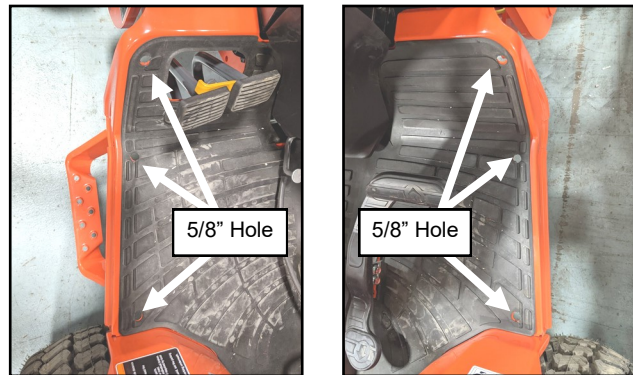

Fig. 1.3 (Pull Up Floor Mat)



Fig. 1.4 (Punch Hole to Remove Plug)



Figs. 1.5a and 1.5b (Punch Holes to Remove Plugs)



# CAB INSTALLATION

## STEP 1: (VEHICLE PREP, CONT'D)

- 1.6 Disconnect the rear flasher wires. Remove the rear cross panel holding the toolbox and rear flashers, or remove the flasher brackets and flashers, depending on what is installed. Save the flashers for reuse at a later step. See Figures 1.6a and b.
- 1.7 Remove the grab handles, left lever console, and cup holder, if installed. See Figure 1.7. Use some of the supplied orange decals to cover the grab handle mounting holes. After the cab is installed, the rest of the decals may be used to cover any remaining holes.
- 1.8 Apply the supplied bulb rubber to the top of the left floorboard. Run one continuous strip all the way along the edge of the rubber floor mat. See Figure 1.8.
- 1.9 Repeat step 1.8 for the right side floorboard.



Fig. 1.6a (Remove Rear Flashers)



Fig. 1.6b (Remove Rear Flashers)



Fig. 1.7 (Remove Left Lever Console)

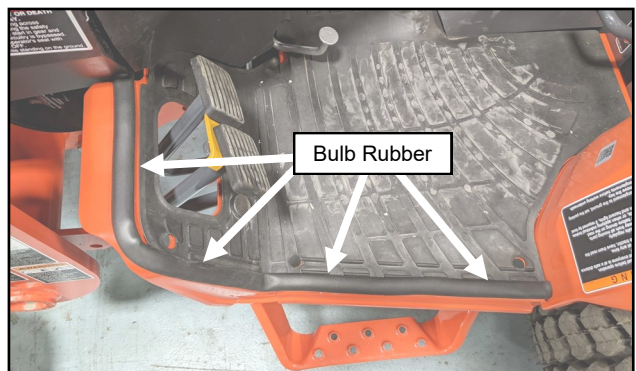

Fig. 1.8 (Apply Bulb Rubber to Floor Board)

# CAB INSTALLATION

## STEP 2: (ROPS BRACKETS)

- 2.1 If required, use a knife or scissors to cut the foam from the ROPS bracket mounting holes. See Figure 2.1.
- 2.2 Attach the left ROPS bracket to the ROPS. See Figure 2.2. Leave hardware loose.

<u>Hardware Used</u>	<u>Qty</u>
5/16-18 X 2-3/4" Hex Head Screw	2
5/16" Fender Washer	4
5/16-18 Hex Nut	2

Tools required  
1/2" wrench and socket

- 2.3 Attach the right ROPS bracket to the ROPS. If required, sandwich the optional toolbox mount between the right ROPS bracket and the fender washers. See Figure 2.3. Leave hardware loose.

<u>Hardware Used</u>	<u>Qty</u>
5/16-18 X 2-3/4" Hex Head Screw	2
5/16" Fender Washer	4
5/16-18 Hex Nut	2

Tools required  
1/2" wrench and socket

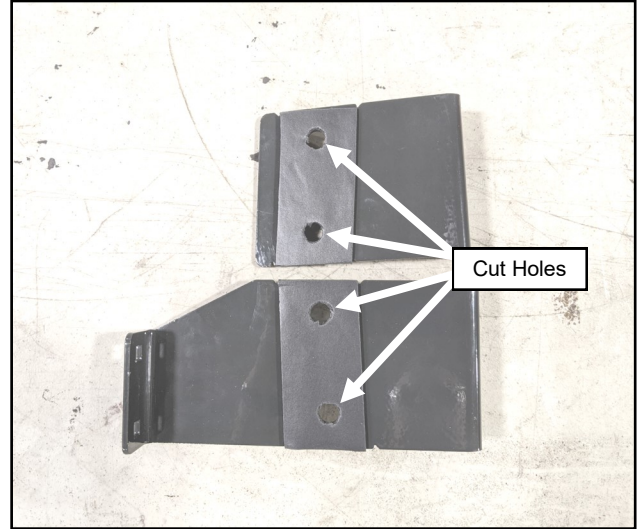

Fig. 2.1 (Cut Out Foam From ROPS Mounting Holes)



Fig. 2.2 (Install Left ROPS Bracket)

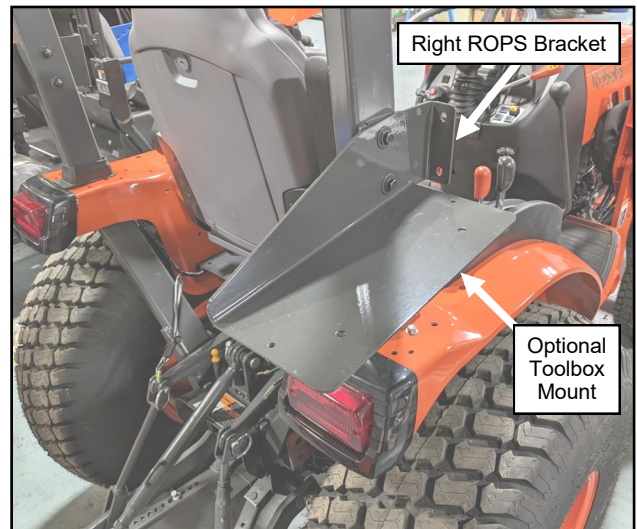

Fig. 2.3 (Install Right ROPS Bracket)

# CAB INSTALLATION

## STEP 3: (ASSEMBLE SIDE FRAMES AND REAR LEGS)

- 3.1 Attach the left rear leg to the left side frame. See Figure 3.1. Align the top of the rear leg to the top of the side frame and tighten hardware.

**Hardware Used**

5/16-18 X 3/4 Hex Head Screw

**Qty**

5

**Tools required**

1/2" wrench or socket

- 3.2 Attach bulb rubber to the side frame and rear leg assembly in one continuous strip. See Figure 3.2.
- 3.3 Repeat steps 3.1 and 3.2 for the right side frame and right rear leg.

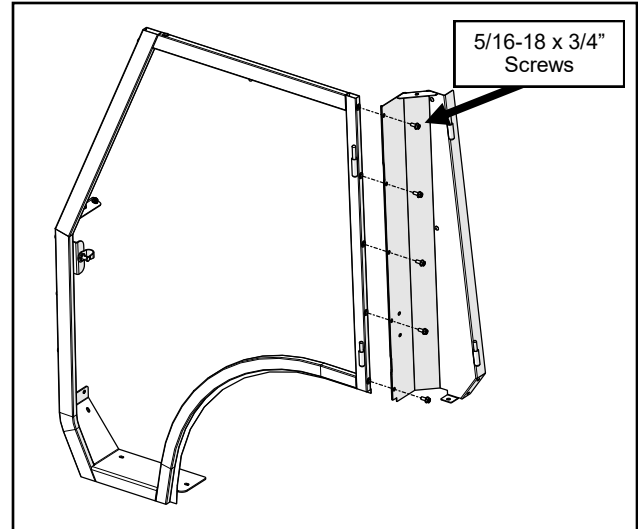

Fig. 3.1 (Assemble The Left Side Frame and Rear Leg)

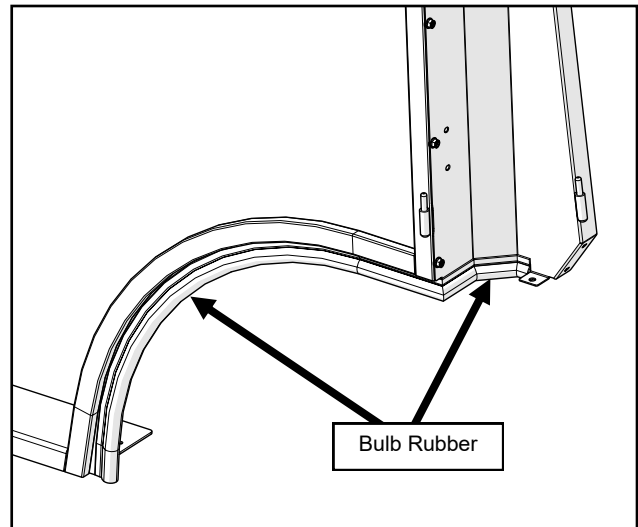

Fig. 3.2 (Attach Bulb Rubber)



# CAB INSTALLATION

## STEP 4: (SIDE FRAMES)

- 4.1 With assistance, set the left side frame in place and loosely secure to the left ROPS bracket. See Figure 4.1.

<u>Hardware Used</u>	<u>Qty</u>
5/16-18 X 3/4 Hex Head Screw	2
5/16-18 Hex Nut	2

Tools required  
1/2" wrench or socket

- 4.2 Secure the left side frame to the floor pan through the hole from the rubber plug removed earlier. See Figure 4.2.

<u>Hardware Used</u>	<u>Qty</u>
5/16-18 X 3/4 Button Head Screw	3
5/16-18 Hex Nut	3

Tools required  
3/16" Allen Wrench  
1/2" wrench or socket

- 4.3 Secure the bottom tab on the rear leg to the fender. See Figure 4.3.

<u>Hardware Used</u>	<u>Qty</u>
5/16-18 X 3/4 Hex Head Screw	1
5/16-18 Hex Nut	1

Tools required  
1/2" wrench or socket

- 4.4 Repeat steps 4.1-4.3 for the right side frame assembly.



Fig. 4.1 (Install Left Side Frame)

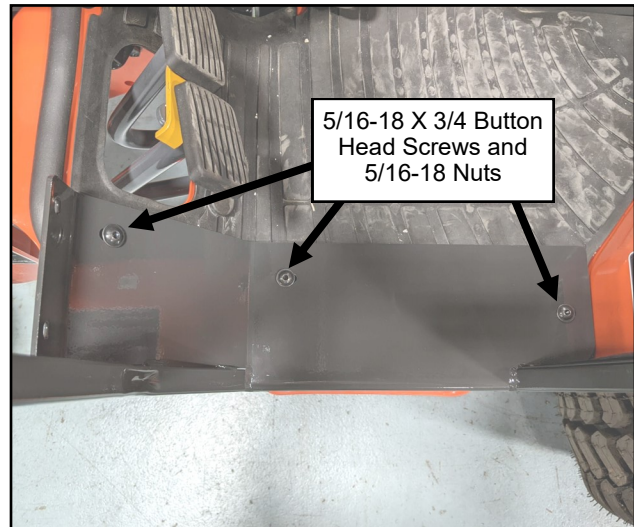

Fig. 4.2 (Install Left Side Frame)



Fig. 4.3 (Install Left Side Frame)

# CAB INSTALLATION

## STEP 5: (WINDSHIELD SUPPORT)

- 5.1 With assistance, hold the windshield support in place and attach with a screw to the front of each side frame. See Figure 5.1. Do not screw in the top at this point.

<u>Hardware Used</u>	<u>Qty</u>
5/16-18 X 3/4 Hex Head Screw	2

Tools required  
1/2" wrench or socket

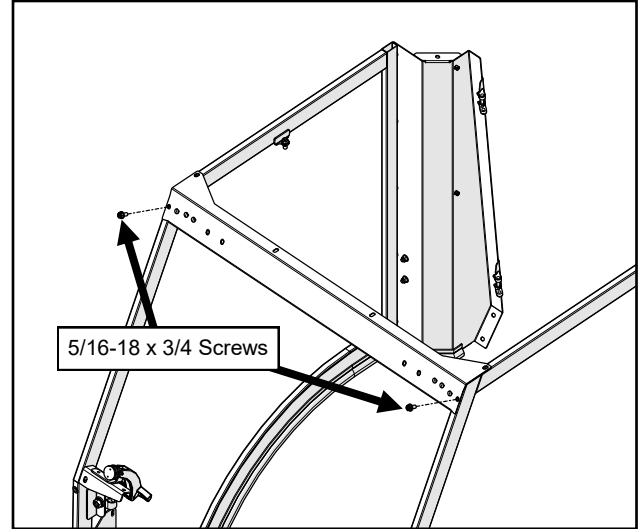

Fig. 5.1 (Install Windshield Support)

## STEP 6: (COWL)

- 6.1 With assistance, carefully slide the cowl in place and loosely secure with fasteners. See Figure 6.1.

<u>Hardware Used</u>	<u>Qty</u>
5/16-18 X 3/4 Hex Head Screw	14
5/16-18 Hex Nut	8

Tools required  
1/2" wrench and socket

- 6.2 For the left side of the hood and cowl, pull the cowl seal out on top of the hood in the center, then transition it to behind the hood at the corner. See Figure 6.2.

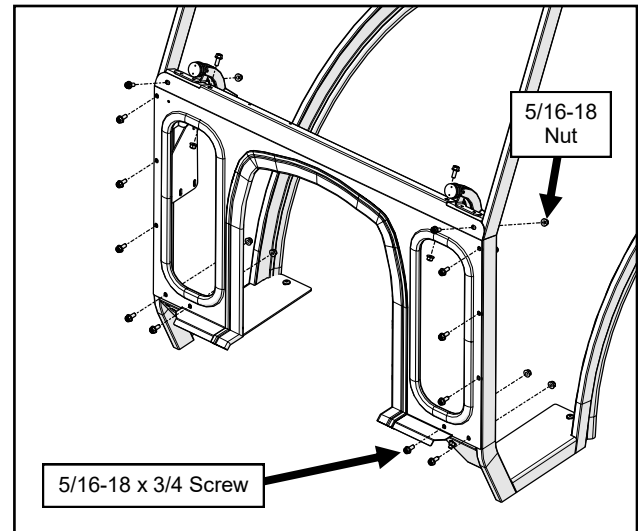

Fig. 6.1 (Install Cowl)

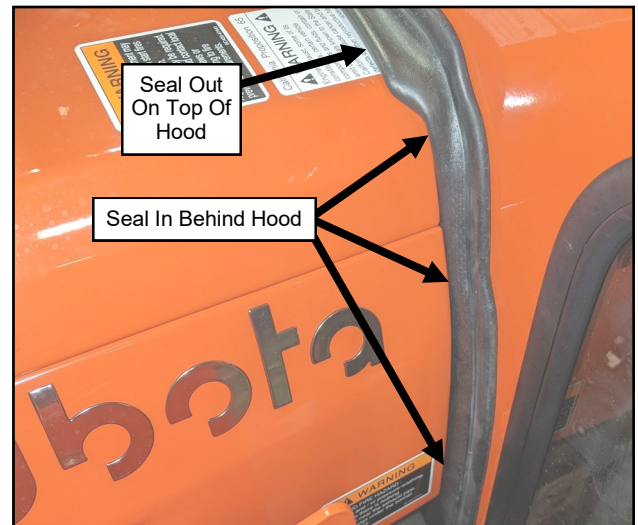

Fig. 6.2 (Left Side Of Hood And Cowl)



# CAB INSTALLATION

## STEP 6: (COWL CONT'D)

- 6.3 Pull the cowl seal out over the left side cover and keep it outside all the way to the front edge. See Figure 6.3.
- 6.4 On the right side, pull the cowl seal out on top of the hood in the center, then transition it to behind the hood at the corner. See Figure 6.4.
- 6.5 Pull the cowl seal out over the right side cover and keep it outside all the way to the front edge. See Figure 6.5.

**NOTE: The engine side covers will be removed at a later step for the heater and wiring harness installation. Ensure the cowl seal is correct after the side covers go back on.**

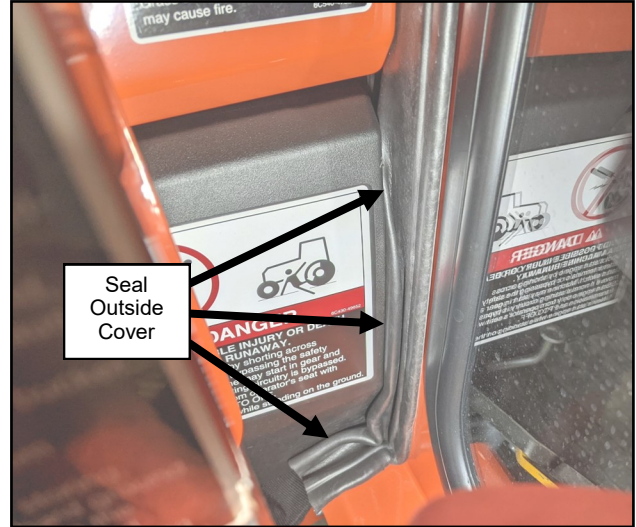

Fig. 6.3 (Left Side Of Cowl)

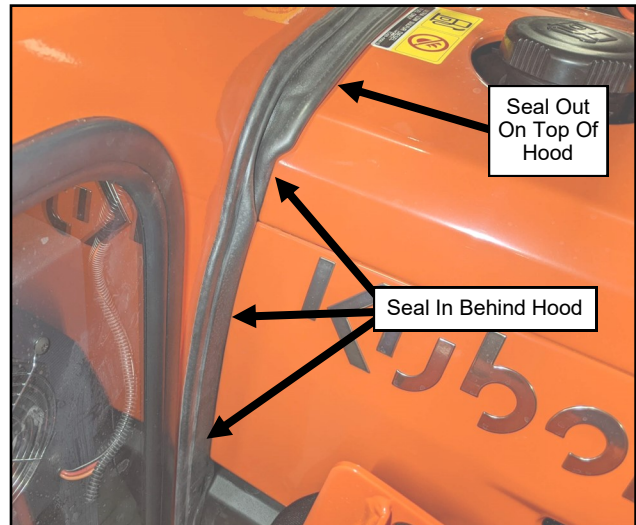

Fig. 6.4 (Right Side Of Hood And Cowl)



Fig. 6.5 (Right Side Of Cowl)

# CAB INSTALLATION

## STEP 6: (COWL CONT'D)

- 6.6 Open the hood to check the seal. See Figures 6.6a and b. The seal should stay in roughly the same position. Close the hood and check that the seal is still as it should be.



Fig. 6.6a (Left Side Of Hood)



Fig. 6.6b (Right Side Of Hood)

## STEP 7: (LOWER REAR PANEL)

- 7.1 With assistance, hold the lower rear panel in place and loosely secure with fasteners. See Figure 7.1.

<u>Hardware Used</u>	<u>Qty</u>
5/16-18 X 3/4 Hex Head Screw	4
5/16-18 Hex Nut	4

Tools required  
1/2" wrench and socket

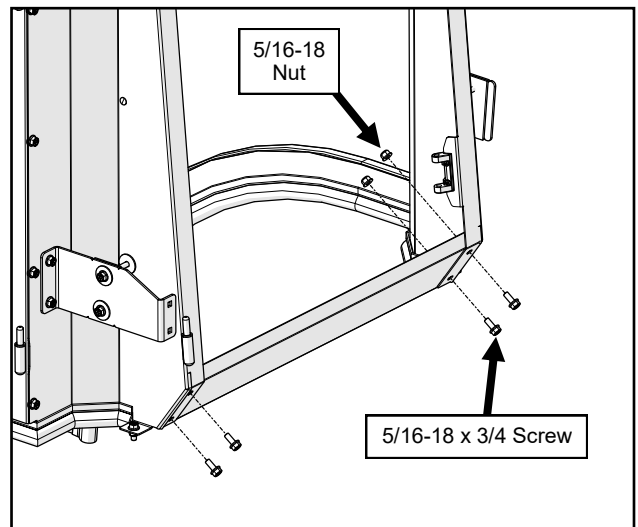

Fig. 7.1 (Install Lower Rear Panel)

# CAB INSTALLATION

## STEP 8: (WINDSHIELD)

- 8.1 Check the windshield support for squareness to the side frames and tighten the two screws to 12.5 ft.-lbs.
- 8.2 With assistance, set the windshield up to the side frames and secure it to the windshield support using the hinge spacers and hardware. See Figure 8.2. Leave hardware loose.

### Hardware Used

	Qty
5/16-18 x 1.5" Flat Head Screw	4
5/16-18 Hex Nut	4

### Tools required

#3 Phillips screw driver  
 1/2" wrench or socket.

- 8.3 Secure the windshield latches to the side frames with the latches open, and tighten latch hardware. See Figure 11.3.

### Hardware Used

	Qty
1/4-20 x 5/8" Hex Head Screw	4
1/4-20 Hex Nut	4

### Tools required

3/8" wrench/socket  
 7/16" wrench/socket

- 8.4 Close the windshield while lifting up on the bottom edge. Tighten hinge hardware. **Caution: The windshield hinges are plastic components. Do not overtighten the flat head screws. Torque to 7 ft.-lbs. max.**

### Tools required

Torque Wrench

- 8.5 Ensure the windshield latches function properly and the windshield pivots open.
- 8.6 Remove the over-tightening caution decal from the top of the windshield.

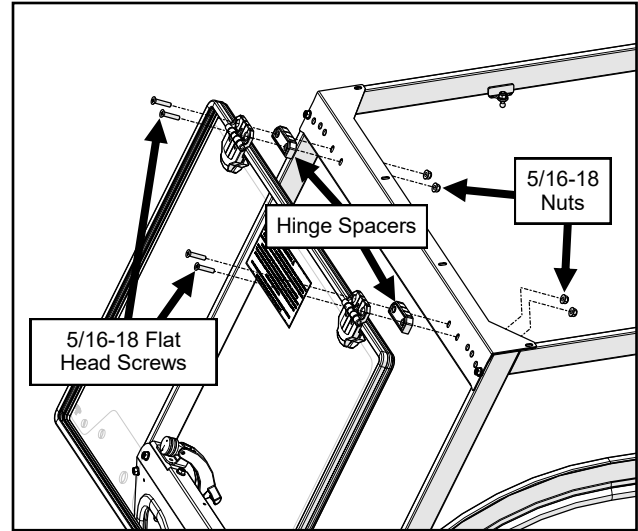

Fig. 8.2 (Attach Windshield)

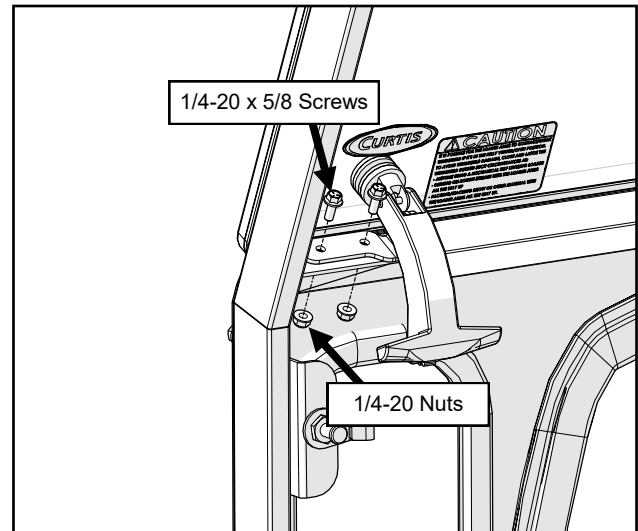

Fig. 8.3 (Secure Windshield Latches)

## STEP 9: (WINDSHIELD WIPER MOTOR)

- 9.1 Mount the wiper motor to the windshield. See Figure 9.1.

**NOTE: Do not install the wiper arm and blade at this time. Once all the wiring is complete and power is restored, it can be turned on and off to ensure that the wiper arm will be parked in the correct position once it is attached at a later step.**

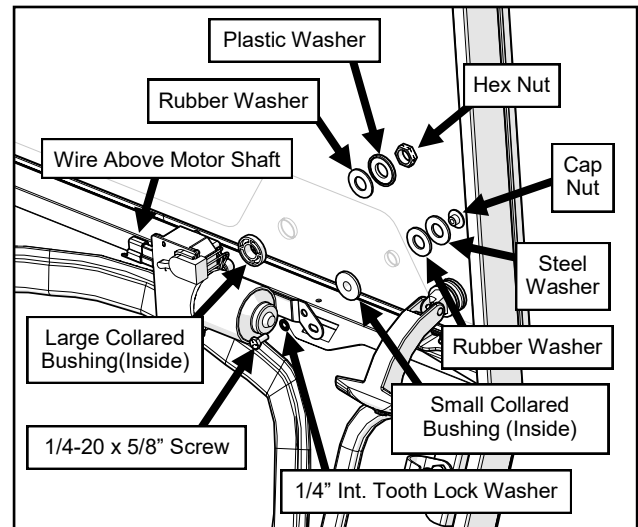

Fig. 9.1 (Windshield Wiper Motor)

# CAB INSTALLATION

## STEP 10: (ROOF)

**NOTE:** If installing a Backhoe Compatibility Kit, refer to the Backhoe Compatibility Kit Installation Instructions for the roof installation and then proceed to step 11 of these installation instructions.

- 10.1 With assistance, set the roof on top of the cab. Loosely secure with sealing washers on the (6) screws through the top of the roof. See Figure 10.1.

### Hardware Used

	<u>Qty</u>
5/16-18 x 3/4" Hex Head Screw	6
5/16" Sealing Washer	6
5/16-18 Hex Nut	4

### Tools required

1/2" Wrenches and/or Sockets

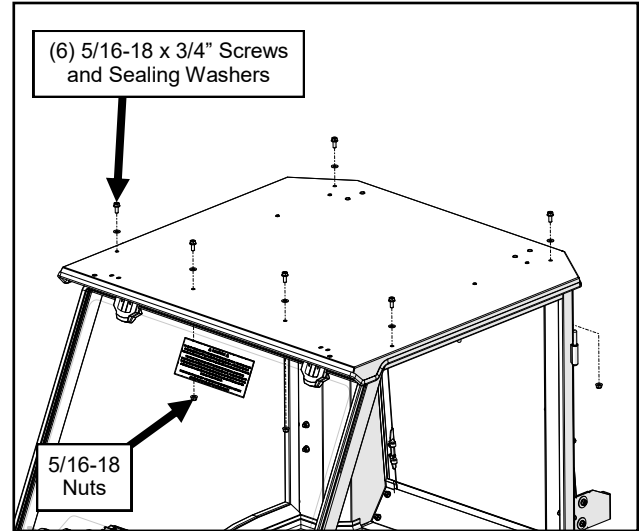

Fig. 10.1 (Install Roof)

## STEP 11: (REAR WINDOW OR CURTAIN)

- 11.1 Measure the back of the rear legs, inside to inside, and adjust the width to 24-7/8". Measure corner to corner for squareness, and **tighten the (8) sets** of screws and nuts to lock in this width. See figure 11.1

### For Curtis Advantage Cab (cab with steel doors):

- 11.2 Grease the hinge pins for the rear window, and slide on greased brass washers (one washer per pin). See Figure 11.2.
- 11.3 Hang the rear window on the hinges.
- 11.4 Connect the window latches to the right rear leg by depressing the tabs on the latch and inserting into the receivers mounted on the rear leg. Close and check the alignment of the window. If off, check measurements and re-align the rear legs. Tighten the hinge hardware to 7 ft.-lbs. Verify smooth operation of the latches.

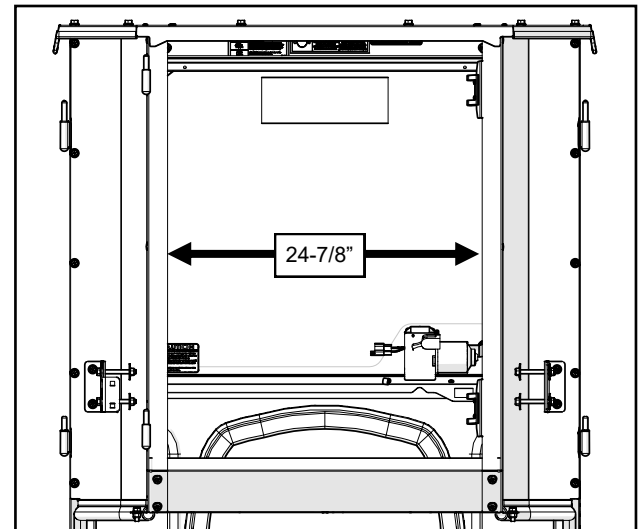

Fig. 11.1 (Measure Rear Legs Left to Right)

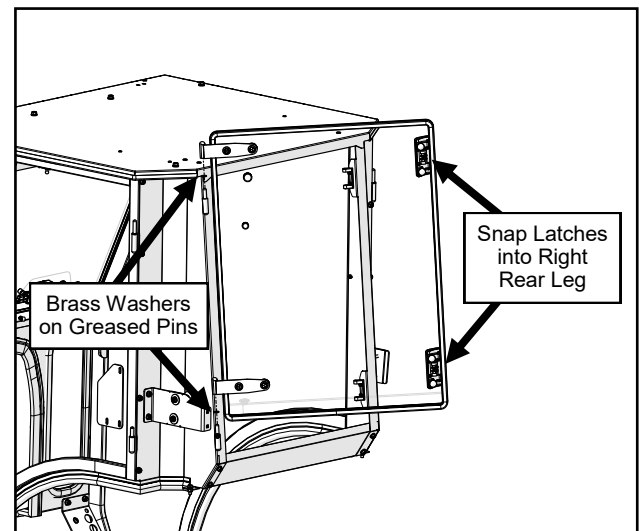

Fig. 11.2 (Hang Rear Window)

# CAB INSTALLATION

## STEP 11: (REAR WINDOW OR CURTAIN, CONT'D)

For Plus Cab (cab with vinyl hinged doors):

- 11.5 Pre-install the supplied Velcro to the rear curtain. Leave the release tape on until the filler is in place. The Velcro for the top and bottom of the filler could also be pre-installed onto the inside of the roof and the outside of the lower rear panel instead.
- 11.6 Starting with the top edge, attach the rear curtain to the roof. See Figure 11.6.
- 11.7 Before attaching the sides, pull the curtain down tight and attach to the outside of the lower rear panel. See Figure 11.7.
- 11.8 Secure the sides to the inside of the rear legs.



Fig. 11.6 (Attach Rear Curtain)

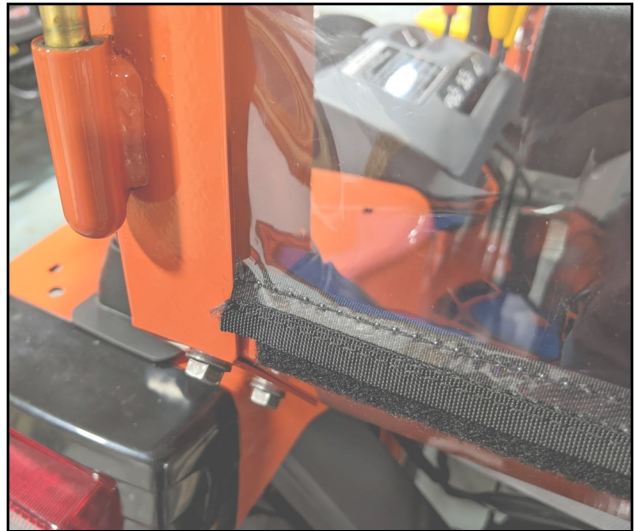

Fig. 11.7 (Attach Rear Curtain)

## STEP 12: (TIGHTEN HARDWARE)

- 12.1 Tighten all hardware at this time, using the torque values given below.

Each side frame can be pushed inward at the back to close any gaps along the fender contour before tightening hardware.

For 5/16" bolts that thread into factory installed threaded inserts in the side frames without plastic washers, use 20 ft.-lbs.

For 5/16" bolts that use plastic washers, use only 12.5 ft.-lbs.

For the remaining 5/16" bolts (the vast majority on the cab) that thread into hex nuts, use 28 ft.-lbs.

For all other bolt sizes, reference the torque tables at the end of the manual.



# CAB INSTALLATION

## STEP 13: (CAB WIRING)

13.1 Attach the main power wire harness to the windshield wiper connector, and secure to the cowl using P-clips and hardware. Make sure there is enough slack to fully open the windshield and that the harness does not get pinched when the windshield closes. See Figure 13.1.

<u>Hardware Used</u>	<u>Qty</u>
#10-32 x 1/2" Pan Head Screw	2
#10-32 Hex Nut	2

Tools required  
 #2 Phillips Screw Driver  
 3/8" Wrench or Socket.

13.2 Snap in the heater switch into the rectangular cutout in the cowl and connect the harness. See Figure 13.2.

13.3 Secure the harness to the cowl with one more P-clip, and route the rest straight down through the 1/2" hole in the floorboard. See Figure 13.3

The rest of the connections will be finished after the heater installation.

<u>Hardware Used</u>	<u>Qty</u>
#10-32 x 1/2" Pan Head Screw	1
#10-32 Hex Nut	1

Tools required  
 #2 Phillips Screw Driver  
 3/8" Wrench or Socket.

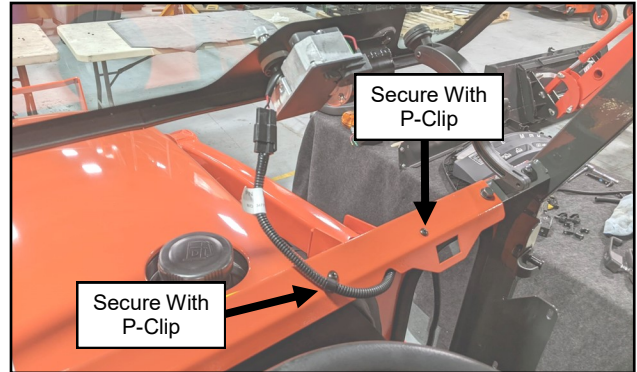

Fig. 13.1 (Attach Main Harness To Wiper Connector)



Fig. 13.2 (Install Heater Switch)



Fig. 13.3 (Harness Runs Down Side Frame)

# CAB INSTALLATION

## STEP 14: (INSTALL HEATER)

14.1 Remove 3 of the case screws on the right side of the heater and reuse them to install the heater to the side frame mounting plate. See Figure 14.1.

### Tools required

#2 Phillips Screw Driver

- 14.2 Connect the heater wires to the wiring harness and cover with the supplied wiring loom. See Figure 14.2.
- 14.3 Install the 2 supplied plastic snap bushings in the right cab floorboard from the inside. See Figure 14.3.
- 14.4 Cover the exposed edge of the vehicle floorboard with some of the supplied Trim-Lok. See Figure 14.3



Fig. 14.1 (Install Heater)



Fig. 14.2 (Connect Heater Wires)

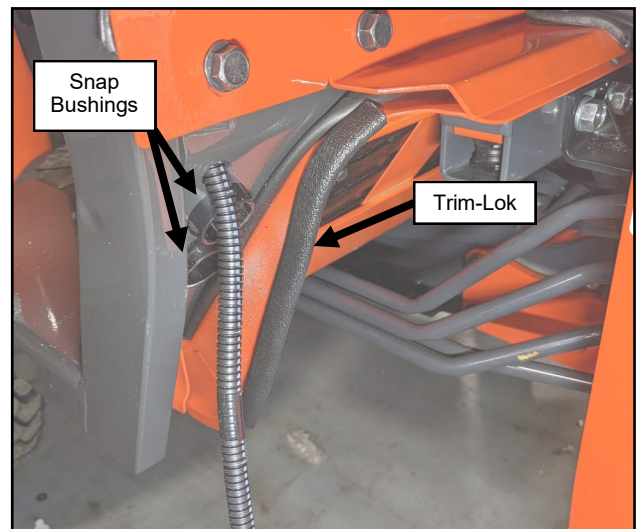

Fig. 14.3 (Snap Bushings and Trim-Lok)



# CAB INSTALLATION

## STEP 15: (HEATER PLUMBING)

- 15.1 Remove the side engine covers and drain the coolant (There is a drain plug on the radiator on the right side).
- 15.2 For easier access, unbolt the exhaust pipe at the bottom, loosen the clamp at the top, and swing the pipe up and out of the way.
- 15.3 Using the supplied T fitting as a guide, mark the lower radiator hose for the necessary cuts. See Figure 15.3. Make sure there will be enough hose between the lower radiator and the T fitting, as well as enough hose between the T fitting and the bend in the hose.
- 15.4 Confirm the coolant has completely drained from the other side and reconnect the drain plug. Relocate your drain pan under the lower radiator hose and cut the hose at one of the marks.
- 15.5 Cut the lower radiator hose at the second mark to remove a short section.
- 15.6 Install the supplied tee fitting between the sections of lower radiator hose using the two large hose clamps, leaving the clamp loose for now. Orient the tee so that it points across the engine bay. See Figure 15.6.
- 15.7 Inspect the lower radiator hose to confirm it is not pushed up against any sharp edges and further trim to length if necessary. Orient the Tee fitting per figure 15.6 and tighten the clamps.
- 15.8 Swing down the exhaust pipe and re-attach and tighten.
- 15.9 Attach one end of the 5/8" hose to the tee with a small hose clamp and route the hose across the engine bay under the radiator. See Figure 15.9.
- 15.10 Route the 5/8" hose along the right side of the engine and through the lower snap bushing in the floorboard. Use the natural curve in the hose to orient it and prevent kinking. See Figure 15.10.

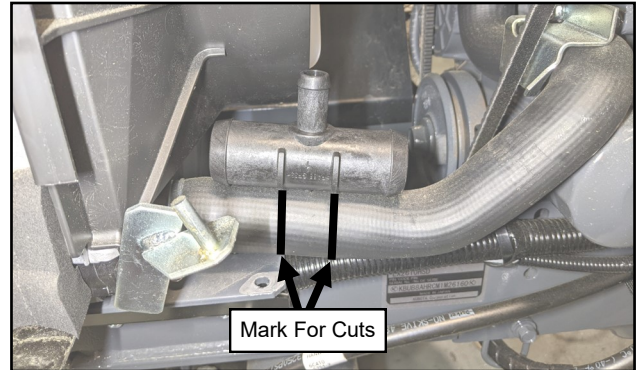

Fig. 15.3 (Mark The Lower Radiator Hose)

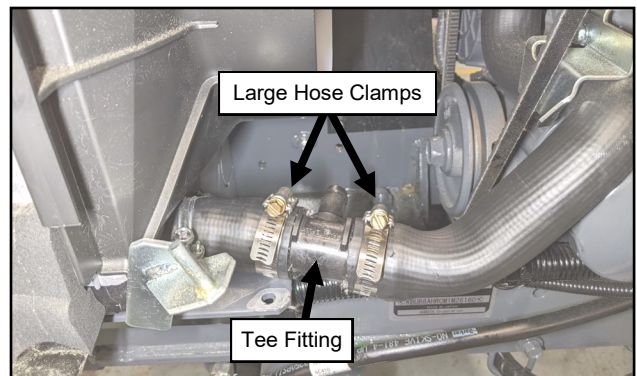

Fig. 15.6 (Install Tee Fitting)

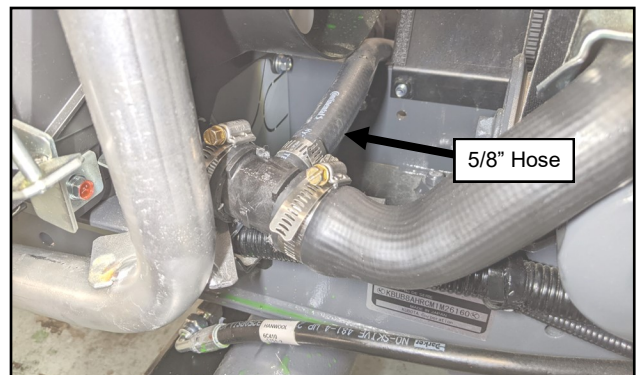

Fig. 15.9 (Attach 5/8" Hose)

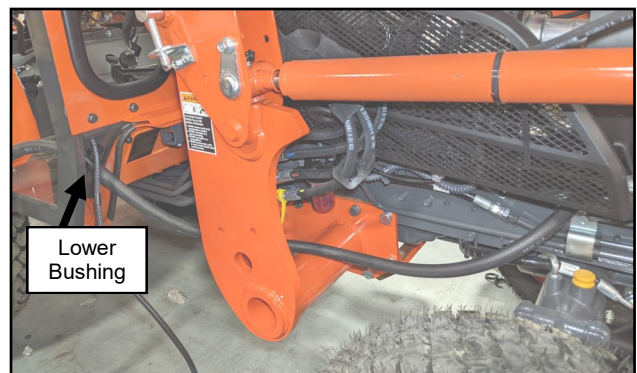

Fig. 15.10 (Route Hose Into Cab)

# CAB INSTALLATION

## STEP 15: (HEATER PLUMBING CONT'D)

- 15.11** Remove the plug from the thermostat housing. Save the brass washer for reuse. See Figure 15.11.
- 15.12** Reuse the brass washer and thread in the hose nipple. See Figure 15.12.
- 15.13** From inside the cab, route the end of the 5/8" hose through the top bushing in the floorboard and along the lower hose toward the engine. Again, use the natural curve of the hose to take corners and prevent kinking. See Figure 15.13.
- 15.14** Continue routing the heater hose along the side of the engine and then up toward the hose nipple. See Figure 15.14.

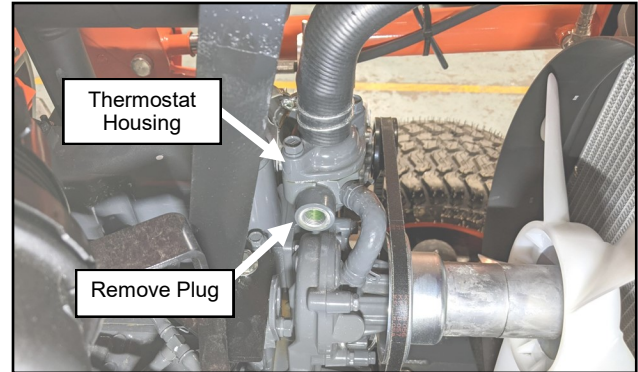

Fig. 15.11 (Remove Plug From Thermostat Housing)

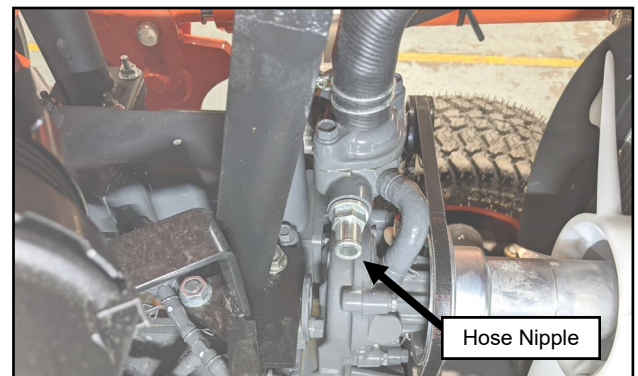

Fig. 15.12 (Install Hose Nipple)

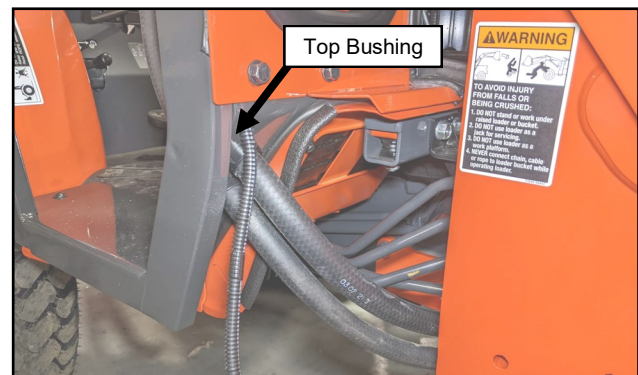

Fig. 15.13 (Route Heater Hose)

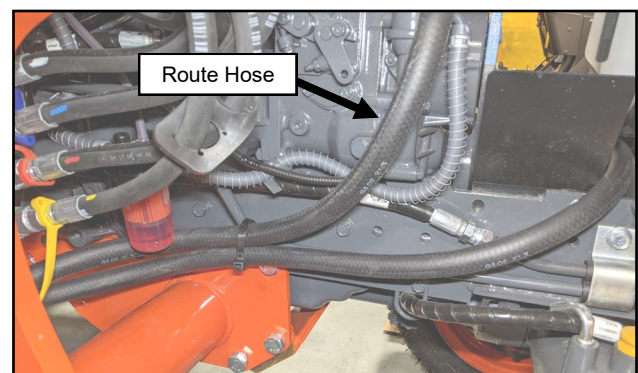

Fig. 15.14 (Route Heater Hose)



# CAB INSTALLATION

## STEP 15: (HEATER PLUMBING CONT'D)

- 15.15** Connect the heater hose to the hose nipple with a small hose clamp. See Figure 15.15.
- 15.16** At installer's preference, select a location to splice the supplied shut-off valve into the supply line coming from the nipple in the thermostat housing. See Figure 15.16. Ensure the engine side cover does not interfere with valve operation.
- 15.17** Inside the cab, cut the hose to length and connect to the heater with small hose clamps. See Figure 15.17.
- 15.18** Use the supplied Trim-Lok to cover any exposed edges of metal that might cut and damage the heater hose. See Figure 15.18.

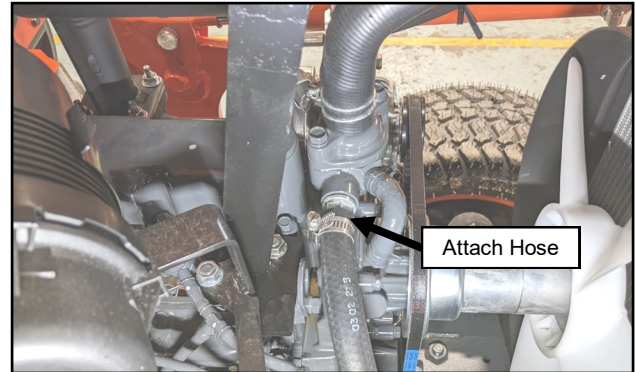

Fig. 15.15 (Attach Hose to Hose Nipple)

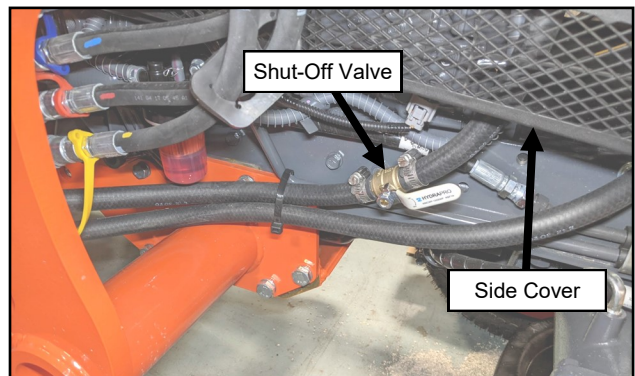

Fig. 15.16 (Heater Shut-Off Valve)

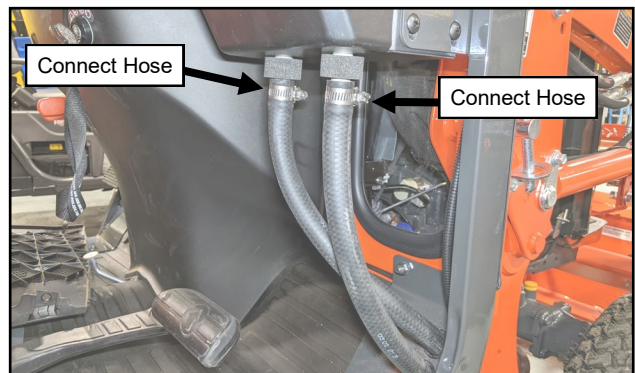

Fig. 15.17 (Connect Hose to Heater)

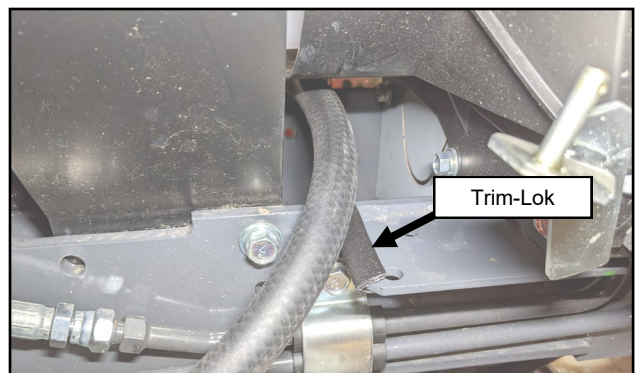

Fig. 15.18 (Add Trim-Lok)



# CAB INSTALLATION

## STEP 16: (FINISH WIRING)

- 16.1** Route the wiring harness behind the engine to the left side of the engine. Use a supplied cable tie to secure the wiring harness to the hydraulic line bracket or suitable alternative. See Figure 16.1.
- 16.2** From the left side, secure the wiring harness to the vehicle wiring harness. See Figure 16.2.
- 16.3** Route the wiring harness around the left side of the engine and around the starter behind the starter wire. See Figure 16.3. Connect the ground terminal to the vehicle bracket shown.

### Hardware Used

M6x1.0 x 12mm Phillips Screw

### Qty

1

### Tools required

#2 Phillips screw driver

- 16.4** Connect the supplied fuse harness ring terminal to the positive post on the starter. See Figure 16.3.
- 16.5** Connect the red wire from the cab power harness to the other side of the fuse harness. Coil up excess harness and wire tie in place.
- 16.6** Refill coolant, connect battery, check system operation.
- 16.7** Re-install the engine side covers. Ensure that the cowl seal is oriented correctly as shown in step 6.

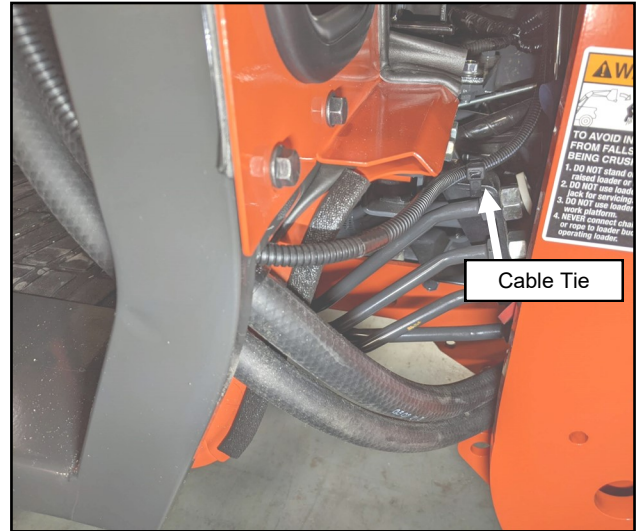

Fig. 16.1 (Secure Wiring Harness)

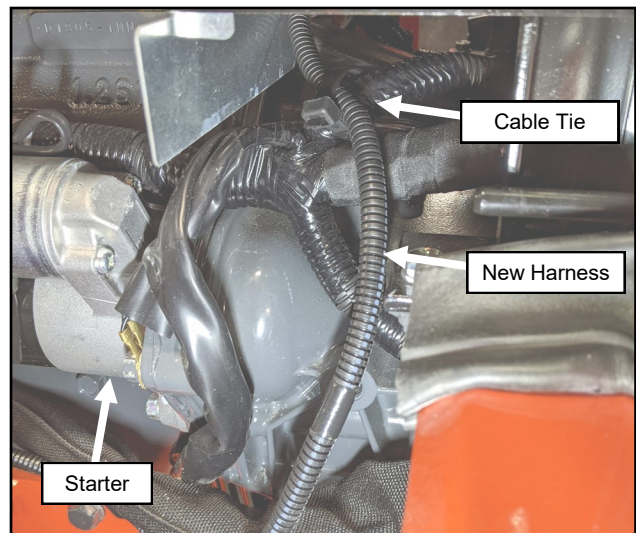

Fig. 16.2 (Secure Wiring Harness)

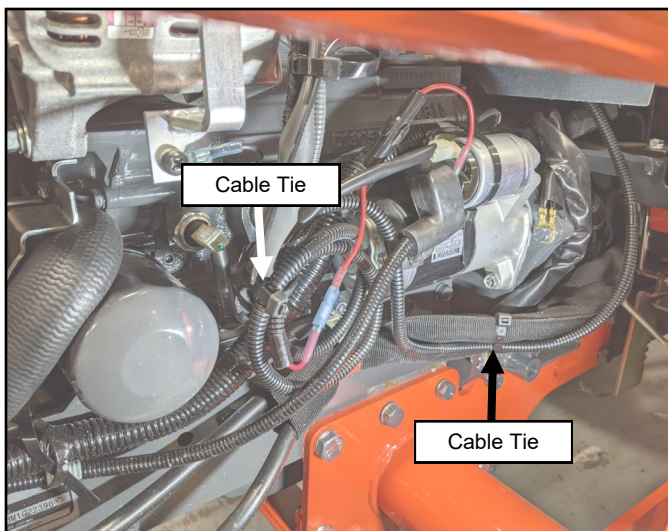

Fig. 16.4 (Secure Excess Wiring)

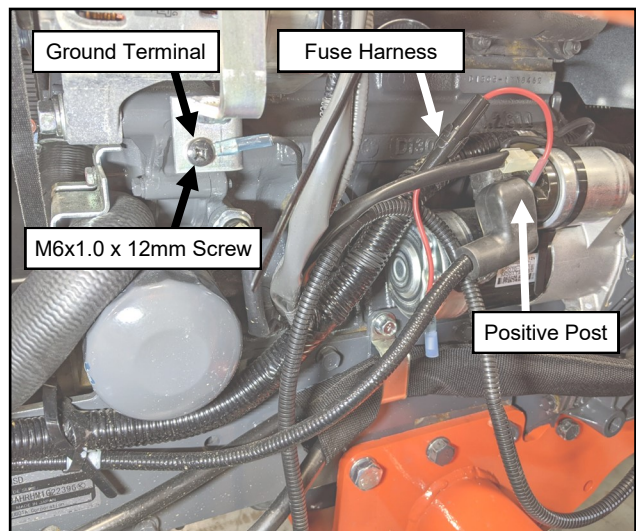

Fig. 16.3 (Connect Ground Terminal and Fuse Harness)

# CAB INSTALLATION

## STEP 17: (WIPER ARM AND BLADE)

- 17.1 Turn on the wiper motor briefly, then turn back off. This will make sure the motor shaft is in the correct parked position.
- 17.2 Pre-assemble the wiper arm and wiper blade.
- 17.3 Install the wiper arm onto the wiper motor so that the wiper is horizontal. See Figure 17.3. Tighten the Allen Screws.

### Tools required

2.5mm Allen Wrench

- 17.4 Adjust the length of the wiper arm as long as possible while still clearing the outer cap nut for the windshield latches. Turn on the wiper to check proper operation and to make sure the blade does not contact the windshield hinge at the top.

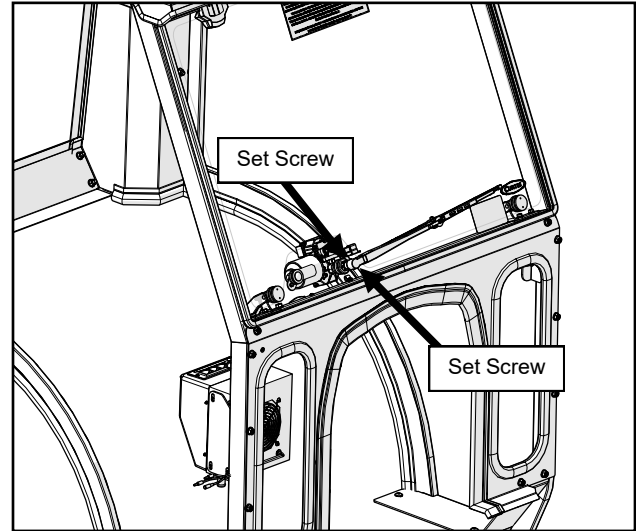

Fig. 17.3 (Wiper Arm and Blade)

## STEP 18: (TOP LINK HOLDER)

- 18.1 If desired, install the top link bracket to the bottom of the lower rear panel. See Figure 18.1. Note: The flat edge of the bracket is mounted to the lower rear panel and the round edge is for the hook.

### Hardware Used

Hardware Used	Qty
5/16-18 x 3/4" Hex Head Screw	1
5/16-18 Hex Nut	1

### Tools required

1/2" Wrenches and/or Sockets

- 18.2 Install the top link hook to the top link bracket. See Figure 18.2. Note: Orientation of the hook opening is personal preference.

### Hardware Used

Hardware Used	Qty
5/16-18 x 1" Hex Head Screw	1
5/16" Fender Washer	1
5/16" ID Spacer	1
5/16-18 Hex Nut	1

### Tools required

1/2" Wrenches and/or Sockets

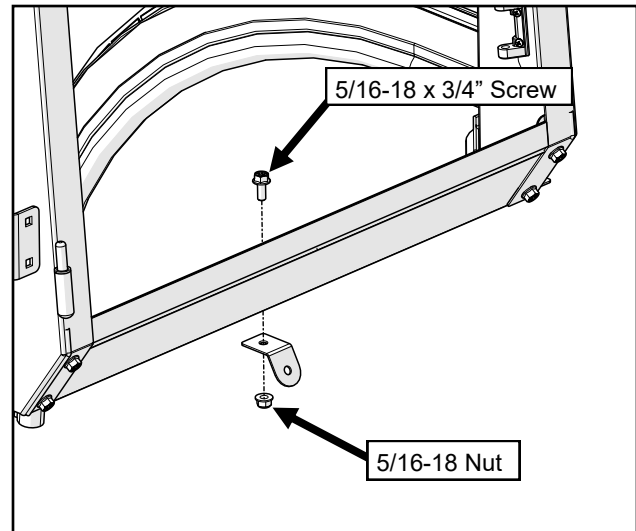

Fig. 18.1 (Install Top Link Bracket)

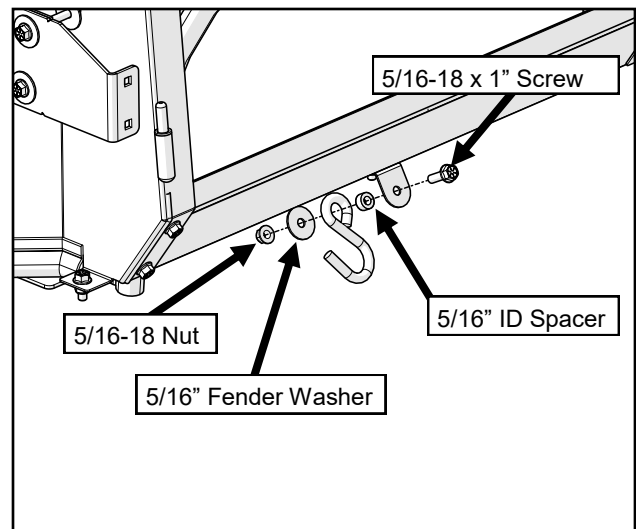

Fig. 18.2 (Install Top Link Hook)

# CAB INSTALLATION

## STEP 19: (UNDER SEAT FILLER)

**NOTE:** Open and/or remove the rear window/curtain for easier access.

- 19.1 If installing the underseat filler with the TLB seat, cut two 4" long slits as shown in Figure 19.1. The flaps will then go up the side of the seat rather than underneath.
- 19.2 Pre-install the supplied Velcro to the under seat filler. Leave the release tape on until the filler is in place.
- 19.3 Tip the seat forward and set the filler in place starting with the slits for the control levers on the left side. See Figure 19.3. Do not stick Velcro yet.
- 19.4 Work the filler down to the bottom of the control levers and underneath the seat belt. See Figure 19.4. Align the front of the filler around the seat switch wire. Do not stick Velcro yet.
- 19.5 Align the rear edge of the filler to the top edge of the Lower Rear Panel. See Figure 19.5. Center the filler side to side on the Lower Rear Panel and secure the Velcro to the panel.
- 19.6 Work the filler down underneath the right side seat belt and around the right side control levers. See Figure 19.6. Do not stick Velcro yet.

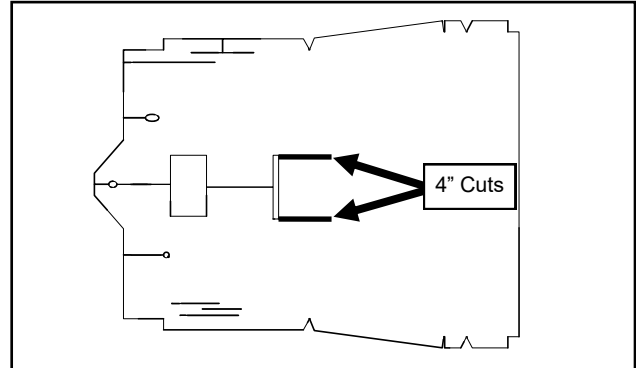

Fig. 19.1 (TLB Seat Alteration)

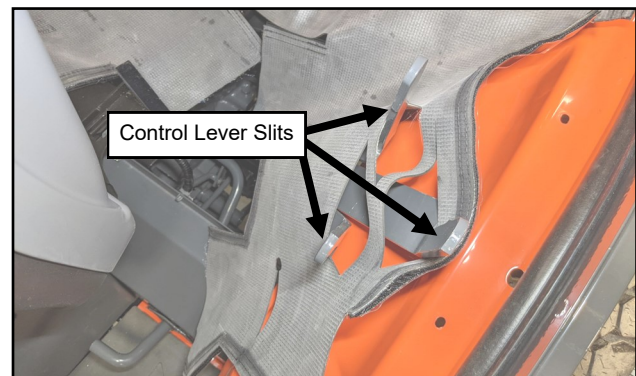

Fig. 19.3 (Set Filler In Place)

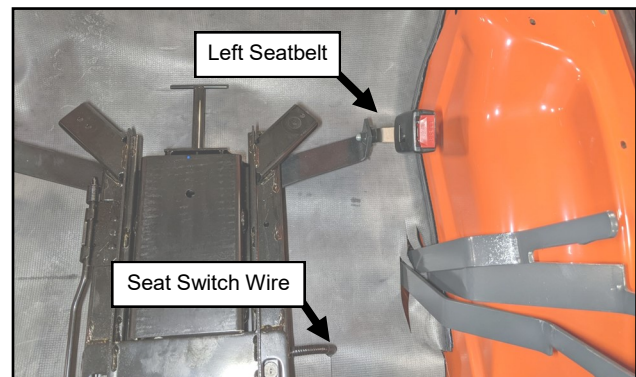

Fig. 19.4 (Position Left Side)

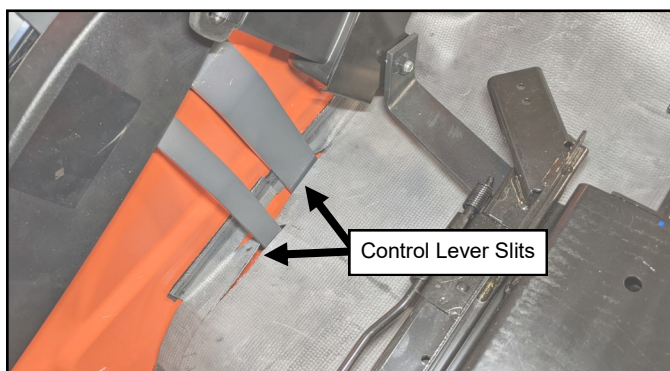

Fig. 19.6 (Position Right Side)

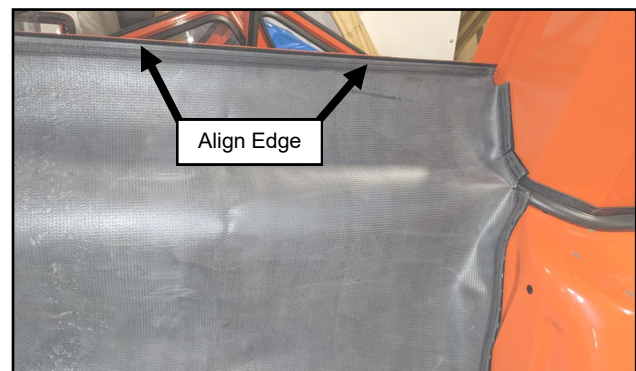

Fig. 19.5 (Secure Filler to Lower Rear Panel)



# CAB INSTALLATION

## STEP 19: (UNDER SEAT FILLER CONT'D)

- 19.7** Position and secure the filler under the seat. See Figure 19.7.
- 19.8** Position and secure the front of the filler. See Figures 19.8a and b. Be sure to minimize gaps.
- NOTE:** If the seat wire runs under the front of the seat, disconnect it and re-run it over the front of the seat. This will allow it to come up through the hole in the underseat filler and keep it away from the loader controls.
- 19.9** Secure any remaining strips of Velcro.
- 19.10** Reattach the left Lever Console and Lever Grips. See Figures 19.10a and b.

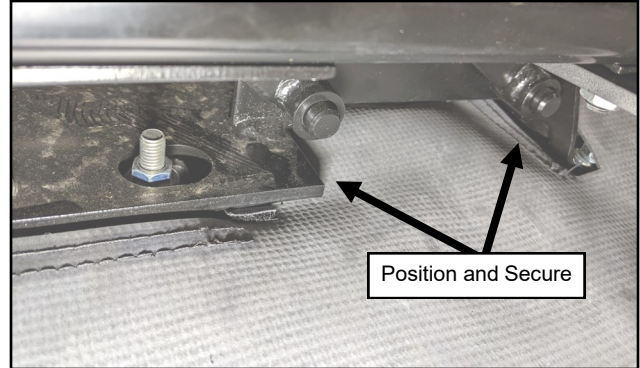

Fig. 19.7 (Secure Filler Under Seat)

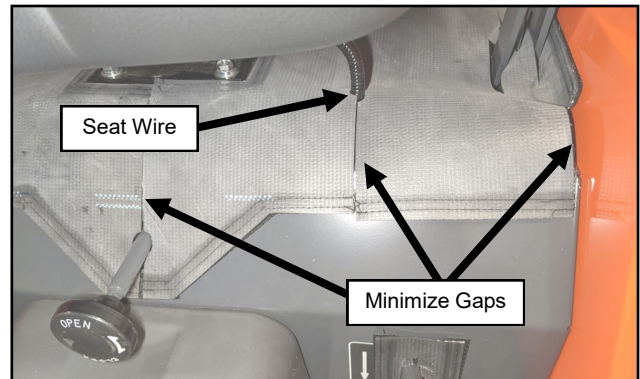

Fig. 19.8a (Secure Front of Filler)

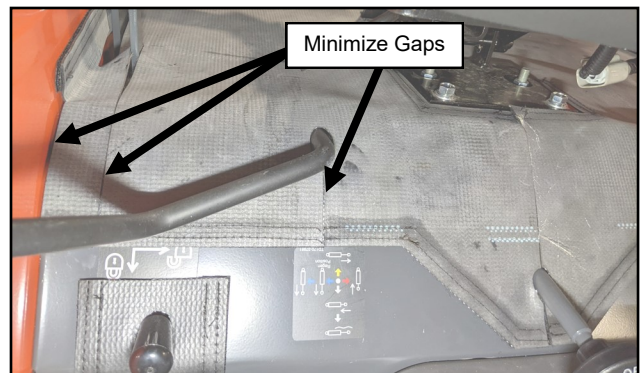

Fig. 19.8b (Secure Front of Filler)



Fig. 19.10b (Reinstall Left Lever Grips)



Fig. 19.10a (Reinstall Left Lever Console)

# CAB INSTALLATION

## STEP 20: (REAR FLASHERS)

**20.1** Attach a rear flasher bracket to the left rear fender as shown using an existing hole in the fender. See Figure 20.1. Tighten hardware.

### Hardware Used

Hardware Used	Qty
5/16-18 x 3/4" Hex Head Screw	1
5/16-18 Hex Nut	1

### Tools required

1/2" Wrenches and/or Sockets

**20.2** Slide the flasher/wires through the top hole in the flasher relocation bracket and tighten the nut. See Figure 20.2.

**20.3** Connect a jumper harness to the vehicle harness and the flasher. See Figure 20.3.

**20.4** Cover any exposed wires and secure to the ROPS with the provided wiring loom and cable ties. See Figure 20.4.

**20.5** Repeat steps 20.1-20.4 for the right side flasher.

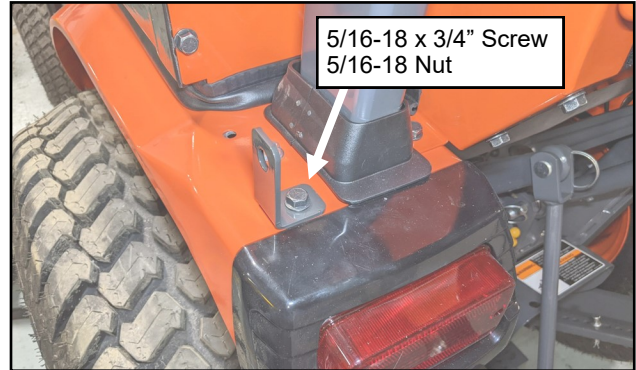

Fig. 20.1 (Attach Flasher Bracket)



Fig. 20.2 (Attach Flasher)



Fig. 20.3 (Connect Jumper Harness)



Fig. 20.4 (Cover With Loom)



# CAB INSTALLATION

## STEP 21: (SMV Bracket)

21.1 Install the SMV bracket that was removed from the rear cross, if equipped.

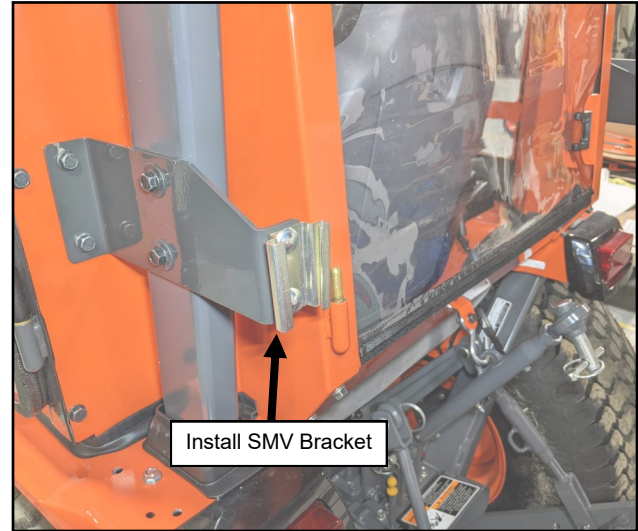

Fig. 21.1 (Install SMV Bracket)

## STEP 22: (ACCESSORIES)

22.1 Install any optional accessories at this time.

22.2 Install the toolbox onto the toolbox mount, if required.

<u>Hardware Used</u>	<u>Qty</u>
5/16-18 X 3/4 Button Head Screw	2
5/16-18 Hex Nut	2

Tools required  
 3/16" Allen Wrench  
 1/2" wrench or socket

### 22.3 Optional Rear Wiper Note:

For easier wiper motor harness disconnection, cut the main wiring harness connector off a few inches from the end and create a jumper harness with it using bullet connectors. **Do not cut the connector off the wiper motor.**

Strip all the wires, crimp a male bullet connector onto the ground (black) wire of the main wire harness and a female bullet connector on the positive (red) wire.

Reverse the male and female bullet connectors on the new jumper wire harness so that the male bullet connector is on the positive (red) wire and the female bullet connector is on the ground (black) wire.



Fig. 22.2 (Install Toolbox)

# CAB INSTALLATION

## STEP 23: (DOORS)

**23.1** Install the supplied brass washers (one washer per pin) onto the hinge pins on the left side and then apply grease to the pins.

**23.2** Loosen the door hinges to allow for adjustment later. Hang the left door on the hinges. While lifting up and forward on the door handle, line up the door latch with the striker pin and carefully attempt to latch. You should be able to hear 2 clicks as you slowly engage the latch on the pin. If the latch is too far forward or back to latch on the pin, adjust as shown. See Figures 23.2a through c. Then retighten and latch.

**23.3** Stand back and examine the alignment of the door with the roof and the A-pillar. You can adjust this by moving the striker pin up or down as shown to help with alignment. *TIP: In the final step, the front of the door will drop a small amount the first time you open it. Set the front of the door a little bit higher so it aligns properly.* Adjust as necessary until you are happy with the alignment. Have an assistant sit inside the cab and once more carefully close the door like you did in step 23.2. Work with the assistant and tighten the hinge bracket bolts.

**23.4** Open the door and check for smooth operation of the latch. As noted in step 23.3, the door will likely drop a little bit at the front and the striker pin will need to be adjusted down accordingly. Also make sure the door seal is making contact along the perimeter of the door and the latch clicks twice when closing. If necessary, adjust the striker in or out to achieve this.

**23.5** With the door open, attach a gas strut to the ball studs on the side frame and door. Make sure the quick release end is on the side frame so that the gas strut stays with the door if removed for ventilation.

**23.6** If installing a side mirror, do so now. Otherwise, install (2) supplied rubber grommets into the mirror holes.

**23.7** Repeat steps 23.1 through 23.6 for the right door.

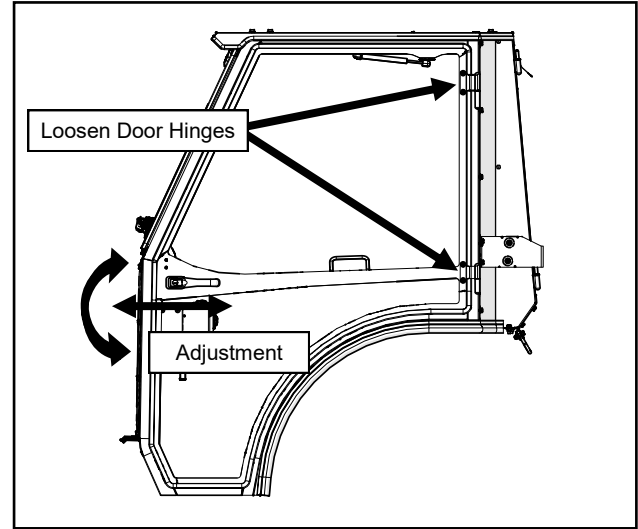

Fig. 23.2a (Door Hinge Adjustment)

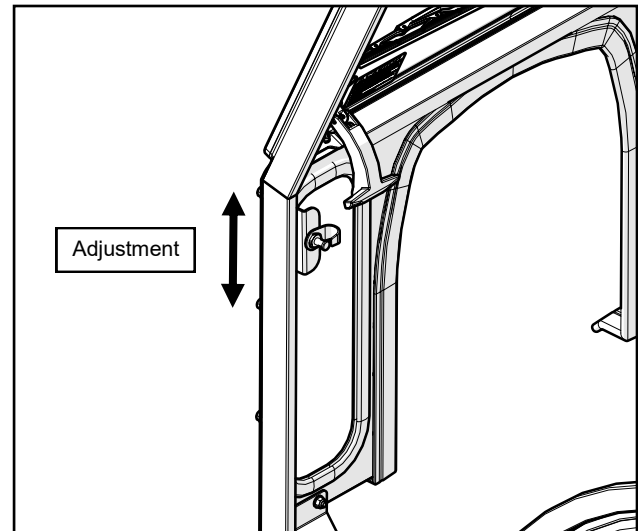

Fig. 23.2b (Striker Pin Adjustment)

## STEP 24: (FINISHING TOUCHES)

**24.1** Due to the nature of the packaging materials used for shipping this product, the components of the cab system may have dust on their surfaces upon removal from the packaging. It is recommended that after completion of the cab installation, the cab and vehicle are washed thoroughly to eliminate any dust or contaminants. See the Care and Maintenance section at the back of this manual for critical information on cleaning the cab.

**24.2** If equipped, re-install the SMV sign.

**24.3** Cover any remaining interior holes with the supplied orange decals.

**24.4** If no side mirrors were installed in Curtis Advantage doors, fill the mirror holes with the supplied rubber hole plugs.

**24.5** Using the supplied plastic hole plugs, fill any remaining holes in the windshield support and rear legs.

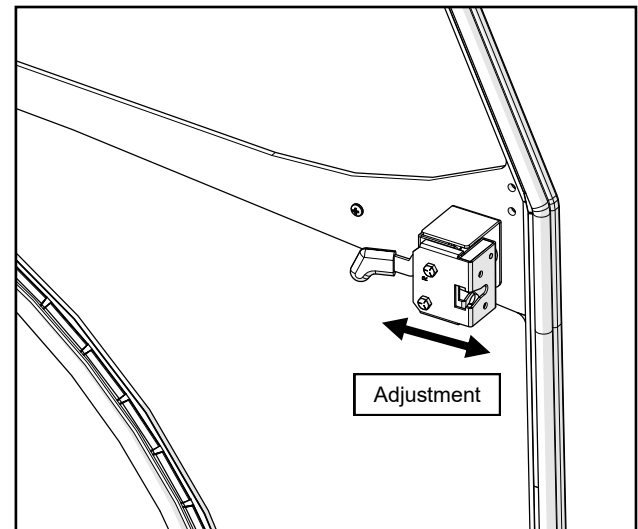
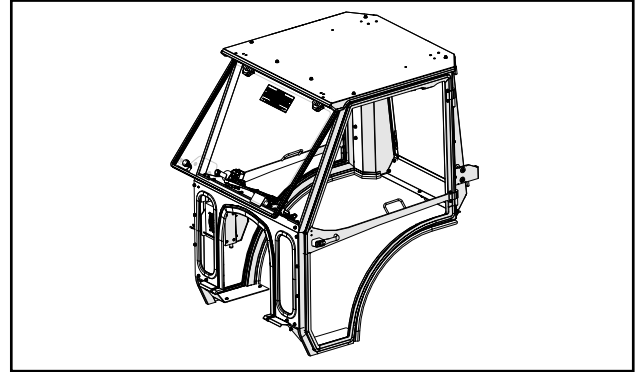

Fig. 23.2c (Door Latch Adjustment)

# CAB FEATURES & OPERATION

## POP-OUT WINDSHIELD

Your LX Series cab comes equipped with a pop-out windshield for ventilation. To open the windshield, simply lift up on both of the pop-out latches and rotate until the latches rest in the over-center position.



Pop-Out Windshield

## LIFT-OFF DOORS

For added ventilation, the doors on the LX Series cab lift off in seconds without tools.

To lift off:

1. Disconnect the gas strut from the side frame by sliding the quick release lever and pulling the strut down.
2. Rotate the doors 90° to the cab and lift. Also, remove the hinge washers and store in a plastic bag.

*Store the doors in a safe location to prevent damage.*

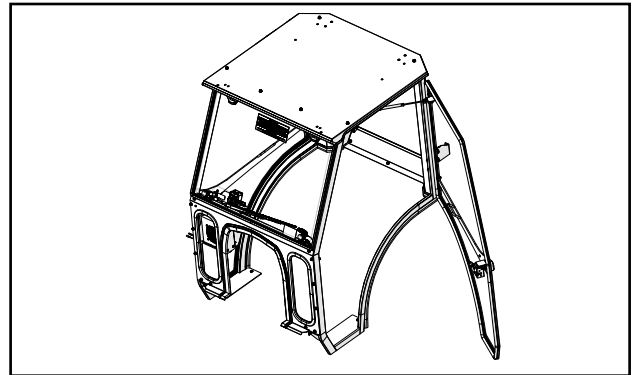

Lift-Off Doors

## REMOVABLE REAR WINDOW OR CURTAIN

The rear window or curtain can also be removed for added ventilation.

To remove the rear curtain:

1. Peel the hook and loop apart around the bottom and side edges and roll the curtain up to the top.
2. Use the sewn-in hook and loop straps to secure the rolled up curtain in place. The curtain can be left attached while rolled up, or it can be removed completely for storage.

To remove the rear window:

1. Open both window latches and disconnect from right rear leg with tabs on latch. Open the window taking care not to let the window open into the ROPS or damage may occur.
2. From outside of the cab, lift up on the rear window and slide off the hinges. Remove the hinge washers and store in a plastic bag.

*Store the rear window in a safe location to prevent damage.*

To reinstall the rear window, reinstall the hinge washers, align the hinges with the pins and drop into place. Re-attach the latches to the rear leg.

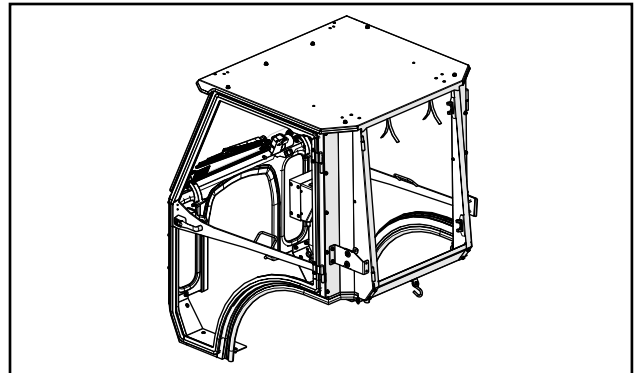

Removable Rear Curtain

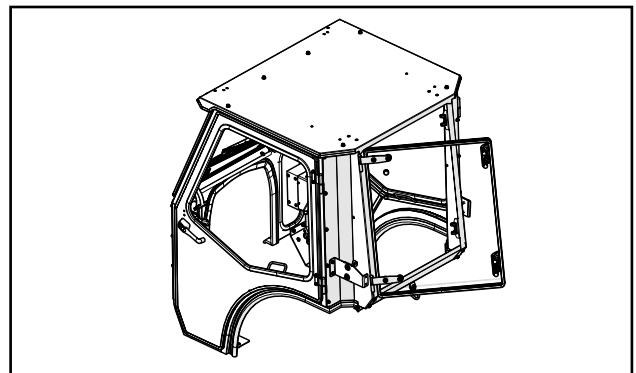

Removable Rear Window



## CARE AND MAINTENANCE

- Re-apply lubrication (preferably grease) periodically as needed to the door striker pins, door latch assemblies, and the door hinges.
- Check and tighten hardware after 40 hours of operation. Periodically inspect and tighten hardware for the remainder of the unit's life.
- Wash the painted surfaces of the cab with commercial automotive cleaning products.
- Clean glass windows with glass cleaner. *Note: Some windows on the cab are acrylic. DO NOT* clean acrylic windows with harsh chemicals. It will damage the plastic. Mild soap and water should be used on all acrylic windows.
- Vinyl components should be washed with a mild solution of warm soapy water.

# KUBOTA LX SERIES CAB SERVICE PARTS

ROOF ASSEMBLY  
P/N: 8SV-101-00065

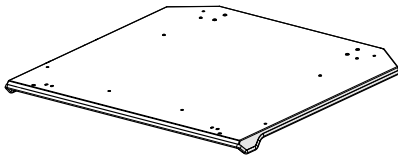

WINDSHIELD ASSEMBLY  
P/N: 8SV-102-00035

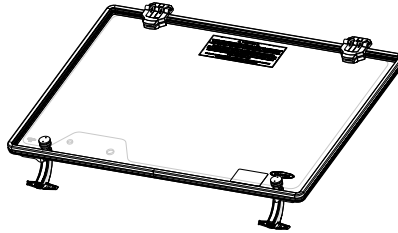

WINDSHIELD SUPPORT  
P/N: 8SV-103-00029

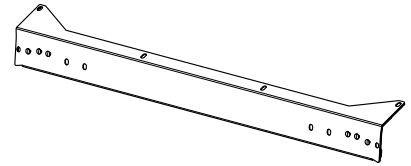

COWL ASSEMBLY  
P/N: 8SV-105-00034

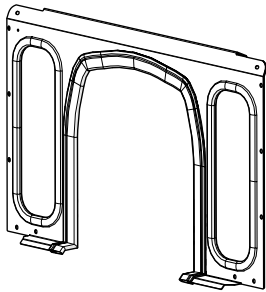

GLASS REAR PANEL LIFT OFF  
P/N: 8SV-106-00021

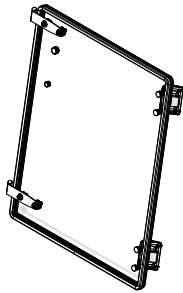

UPPER REAR CURTAIN  
P/N: 8SV-112-00056



LOWER REAR PANEL  
P/N: 8SV-106-00044

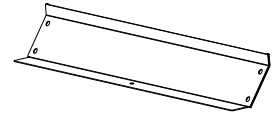

VINYL DOOR, LEFT  
P/N: 8SV-107-00055-L

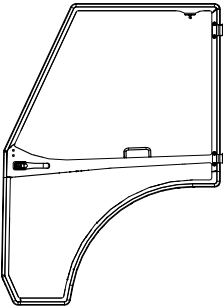

VINYL DOOR, RIGHT  
P/N: 8SV-107-00055-R

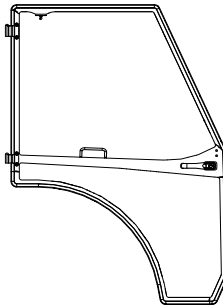

STEEL DOOR, LEFT  
P/N: 8SV-107-00056-L

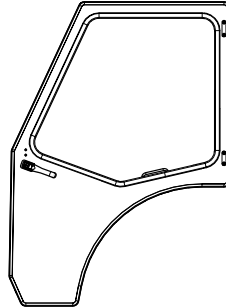

STEEL DOOR, RIGHT  
P/N: 8SV-107-00056-R

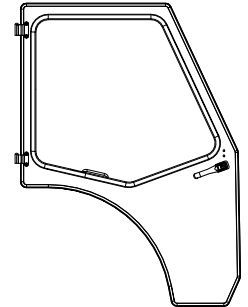

REAR LEGS, LEFT & RIGHT  
P/N: 8SV-108-00027-L & R

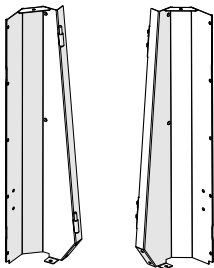

LEFT

RIGHT

SIDE FRAME ASSEMBLY,  
LEFT P/N: 8SV-109-00026-L

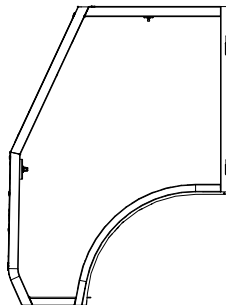

SIDE FRAME ASSEMBLY,  
RIGHT P/N: 8SV-109-00026-R

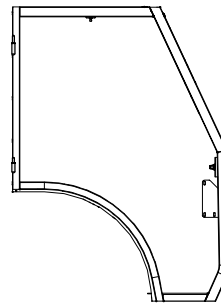

UNDERSEAT FILLER  
P/N: 8SV-111-00041

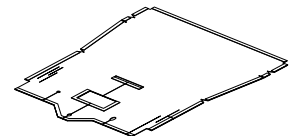

# KUBOTA LX SERIES CAB SERVICE PARTS

VINYL DOOR SKIN, LEFT  
P/N: 8SV-112-00080-L

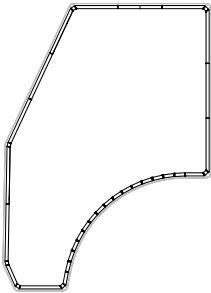

VINYL DOOR SKIN, RIGHT  
P/N: 8SV-112-00080-R

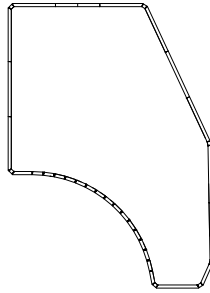

COWL WINDOW  
P/N: 8SV-P-00158



DOOR WINDOW  
P/N: 8SV-P-00170

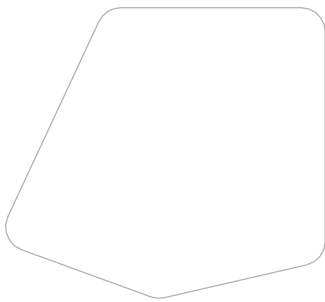

GLASS HINGE SLEEVE WITH  
MOUNTING HARDWARE  
P/N: 8SV-PL-00021

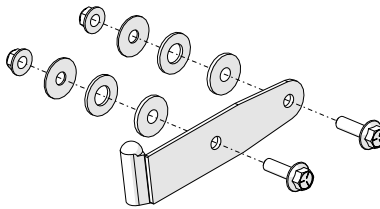

ROPS BRACKET ASSEMBLY SET  
P/N: 8SV-110-00108

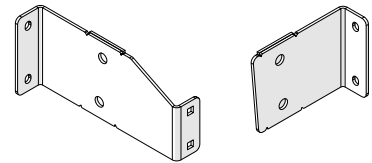

FLASHER RELOCATION BRACKET  
P/N: 8SV-SM-02270

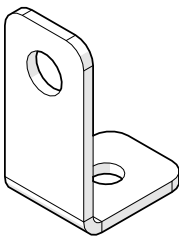

TOOLBOX BRACKET  
P/N: 8SV-SM-02295

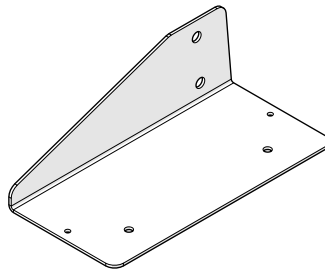



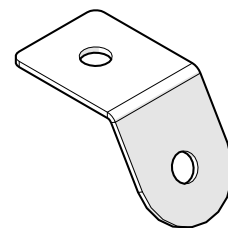



TOP LINK BRACKET  
P/N: 8SV-SM-02303



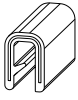

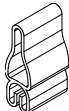
## ADDITIONAL SERVICE PARTS

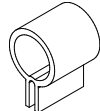
PART NUMBER	DESCRIPTION
9SV-DP11	DOME PLUG 1/2" (BAG OF 10)
9SV-DP10	DOME PLUG 3/8" (BAG OF 10)
9SV-HWSS	WINDSHIELD HINGE KIT WITH SHORT SPACER
9BLK01-S	WINDSHIELD HINGE BLOCK SPACER, SHORT STYLE, 5/8" THICK
9PWM110	WIPER MOTOR, 110 DEGREE
9PWB20-FB	WIPER BLADE, 20", FLEX
9PWA14-16	WIPER ARM, ADJUSTABLE LENGTH (11" - 16")
9PWK-HB	GLASS MOUNTING KIT FOR WIPER SYSTEMS
9SV-DSTRH	DOOR STRIKER KIT-INCLUDES CASE HARDENED STRIKER BOLT
9SV-IHRL	INSIDE HANDLE ROTARY LATCH KIT (INCL. L & R)
9SV-OHRL	OUTSIDE HANDLE ROTARY LATCH KIT (SET OF 2)
9SV-9PHW010-W	HINGE WASHER, KIT (SET OF 4) OD .635, ID .41, THK .08
9PI01	POLY INSERT 1", 14-20 GA BLK MATTE, INSERT FINIS .94/.95 (QTY.: 1)
9PI02	POLY INSERT 3/4", 14-20 GA BLK MATTE FINISH, INSERT FINIS 0.69 (QTY.: 1)
9SV-WL1	WINDSHIELD LATCH KIT 1, POPS OPEN W/S FOR VENTING ONLY
9SV-GS02Q	GAS SPRINGS, 12-3/8 EXT, QUICK DISCONNECT ENDS (SET OF 2)
9SV-9HR04	THICK PANEL SNAP BUSHINGS, .937ID X 1.093 OD (SET OF 2)
9SV-9HR-00036	TEE FITTING, 1-3/8" x 1-3/8" x 5/8" (QTY.: ONE)
9HR-BX2660	HEATER NIPPLE, M16.4 X 1.33 (QTY.: ONE)
9SV-9HR0048	ROCKER SWITCH (HI-OFF-LOW) (QTY.: ONE)
9SV-9HR00601.0	HOSE CLAMPS #10 (1") (QTY.: 6)
9SV-9HR00601.5	HOSE CLAMPS #16 (1.5") (QTY.: 2)
9SV-HRH61-20	HEATER HOSE (5/8" I.D.)-20 FT
9SV-9HR-00025	IN-LINE MANUAL SHUT OFF VALVE, 3/4", NSF 14 (QTY.: ONE)
9SV-9HR-L	REPLACEMENT LOUVER-15,000 & 20,000 BTU HEATER (QTY.: ONE, WITH 2 SCREWS)
8SV-9PH20WG	TUCK-AWAY HEATER WITH WIRED GROUND
9PH20-2	FAN 120 x 120 x 38 12VDC 12W 3200 RPM
9SV-WH-00072	WIRING HARNESS, POWER
8SV-WH-GF	WIRE HARNESS, GLASS FUSE (QTY.: ONE)
WH-LTEX-1	LIGHT WIRE EXTENSION KIT (1 EACH)
9DL01H	KEYS, SET OF 2 ON A RING, FOR HANDLE 1096-1, KEY CODE C40
8SV-HKWKG-L	HINGE KIT, TOP & BOT., LEFT
8SV-HKWKG-R	HINGE KIT, TOP & BOT., RIGHT

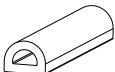
TRIM LOK, STD, 1/16" - 1/8" GRIP	5/8" STD BULB, 1/16" GRIP	1" FLAT BULB, 1/16" GRIP	ARCH PSA RUBBER	WINDOW RUBBER	1" STD BULB, 1/16" GRIP	2" SPONGE RUBBER	3/4" SIDE BULB, 1/4" GRIP	ARCH PSA .2 X .15
								
9SV-PRO1-10	9SV-PRO2-15	9SV-PRO5-10	9SV-PRO9-10	9SV-PR10-10	9SV-PR19-10	9SV-PR35-5	9SV-PR38-15	9SV-PR53-15

# OPTIONAL ACCESSORIES FOR KUBOTA LX SERIES CAB

FRONT LED WORK LIGHTS (P/N: 9LEDW4)

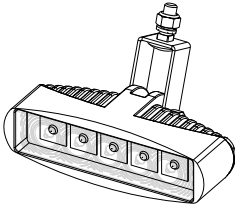

REAR LED WORK LIGHTS (P/N: 9LEDW3)

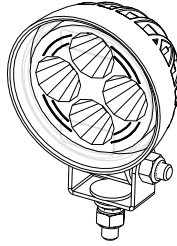

STROBE LIGHT (P/N: 9LEDS2)

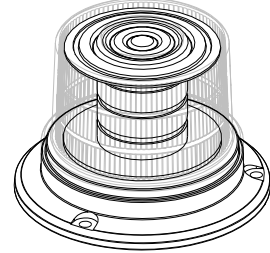

DOME LIGHT (P/N: 9LEDD14)

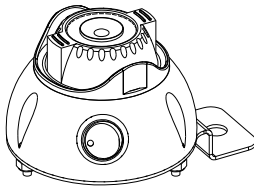

SIDE VIEW MIRRORS (P/N: 9PM5)

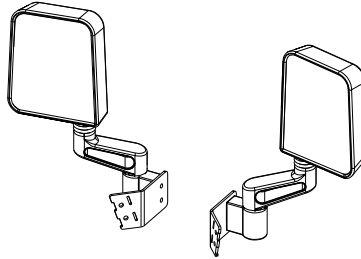

REAR VIEW MIRROR (P/N: 9PM3)

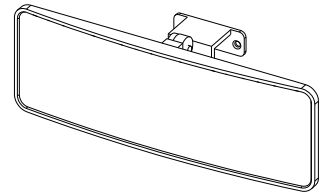

REAR WIPER KIT, 85 DEG W/ 12" FLEX BLADE (P/N: 9PWK8512F9-11A)

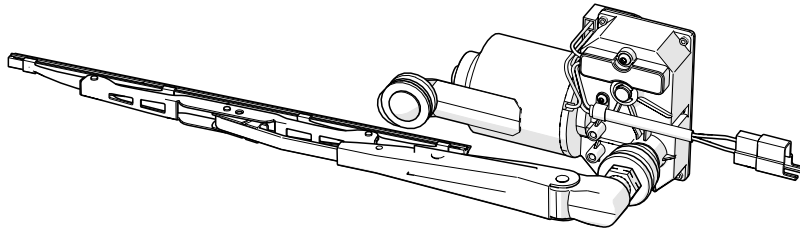

## Tightening of Non-Structural Bolts

For light or medium duty fastening, Curtis recommends using a general industry standard of tightening until snug and then giving an additional one quarter turn of the tool as deemed reasonable for the application (i.e.: at the installer's discretion).

If torque values are required, the examples listed below are intended as a reasonable reference for use in the majority of non-structural fastener applications such as: small diameter fasteners; bolts passing thru tubing, glass, plastic, nylon or rubber washers, threaded inserts, etc.



If more than one application below applies, use the lower torque value.

FASTENER SIZE:	FASTENER TYPE:	WASHER MATERIAL:	APPLICATION:	TORQUE (INCH-POUNDS) (±5)
#10	Machine Screws	-	in Nylon P-Clamps	20
#10	Machine Screws	-	Strobe Light (plastic base)	35
M5	Set Screws	-	Wiper Arm	20
1/4"	Cap Nut	-	Windshield Wiper	20
1/4"	Bolts	-	Tubing (5/8" to 3/4" wide)	132
1/4"	Bolts	Rubber	-	60
1/4"	Bolts	Nylon / Plastic	-	72
1/4"	Bolts	-	Factory Installed Threaded Inserts	132
5/16"	Bolts	-	Tubing (1" or wider)	60
5/16"	Flat Head Bolts	-	Plastic Windshield Hinge	79
5/16"	Bolts	Rubber	-	120
5/16"	Bolts	Nylon / Plastic	-	150
5/16"	Ball Studs	-	-	150
5/16"	Bolts	-	Factory Installed Threaded Inserts	240
3/8"	Bolts	-	Tubing	120
M12	Door Striker Pins	-	-	120

# Torque Specs. for Structural Bolts

This page is for use primarily when dealing with high-strength vehicle fasteners such as ROPS hardware that hold the structure together for safety. This page can also be used for other solid metal-to-metal joints. **Do not** use these high torque values on any of the following applications involving: tubing, plastic, nylon or rubber washers, threaded inserts, etc.. See previous page regarding less critical fasteners.

The values below apply to fasteners that are dry or lubricated with normal engine oil. They do not apply if special graphited or moly disulphide greases or other extreme pressure lubricants are used. This applies to both UNF and UNC threads. Remember to always use the same grade or property class when replacing bolts.

SAE Grade No.		2				5				8*			
Bolt head identification mark as per grade.													
NOTE: Manufacturing Marks Will Vary													
Bolt Size		TORQUE				TORQUE				TORQUE			
		Pounds Feet		Newton-Meters		Pounds Feet		Newton-Meters		Pounds Feet		Newton-Meters	
Inches	Millimeters	Min.	Max.	Min.	Max.	Min.	Max.	Min.	Max.	Min.	Max.	Min.	Max.
1/4	6.35	5	6	7	8	9	11	12	15	12	15	16	20
5/16	7.94	10	12	14	16	17	20.5	23	28	24	29	33	39
3/8	9.53	20	23	27	31	35	42	48	57	45	54	61	73
7/16	11.11	30	35	41	47	54	64	73	87	70	84	95	114
1/2	12.70	45	52	61	70	80	96	109	130	110	132	149	179
9/16	14.29	65	75	88	102	110	132	149	179	160	192	217	260
5/8	15.88	95	105	129	142	150	180	203	244	220	264	298	358
3/4	19.05	150	185	203	251	270	324	366	439	380	456	515	618
7/8	22.23	160	200	217	271	400	480	542	651	600	720	814	976
1	25.40	250	300	339	406	580	696	787	944	900	1080	1220	1464
1-1/8	25.58	-	-	-	-	800	880	1085	1193	1280	1440	1736	1953
1-1/4	31.75	-	-	-	-	1120	1240	1519	1681	1820	2000	2468	2712
1-3/8	34.93	-	-	-	-	1460	1680	1980	2278	2380	2720	3227	3688
1-1/2	38.10	-	-	-	-	1940	2200	2631	2983	3160	3560	4285	4827

\*Thick Nuts must be used with Grade 8 bolts

## METRIC BOLT TORQUE SPECIFICATIONS



Size of Screw	Property Class	Course Thread			Fine Thread		
		Pitch (mm)	Pounds Feet	Newton-Meters	Pitch (mm)	Pounds Feet	Newton-Meters
M6	5.6	1.0	3.6-5.8	4.9-7.9	-	-	-
	8.8		5.8-9.4	7.9-12.7		-	-
	10.9		7.2-10	9.8-13.6		-	-
M8	5.6	1.25	7.2-14	9.8-19	1.0	12-17	16.3-23
	8.8		17-22	23-29.8		19-27	25.7-36.6
	10.9		20-26	27.1-35.2		22-31	29.8-42
M10	5.6	1.5	20-25	27.1-33.9	1.25	20-29	27.1-39.3
	8.8		34-40	46.1-54.2		35-47	47.4-63.7
	10.9		38-46	51.5-62.3		40-52	54.2-70.5
M12	5.6	1.75	28-34	37.9-46.1	1.25	31-41	42-55.6
	8.8		51-59	69.1-79.9		55-68	75.9-92.1
	10.9		57-66	77.2-89.4		62-75	84-101.6
M14	5.6	2.0	49-56	66.4-75.9	1.5	52-64	70.5-86.7
	8.8		81-93	109.8-126		90-106	122-143.6
	10.9		96-109	130.1-147.7		107-124	145-168
M16	5.6	2.0	67-77	90.8-104.3	1.5	69-83	93.6-112.5
	8.8		116-130	157.2-176.2		120-138	162.6-187
	10.9		129-145	174.8-196.5		140-158	189.7-214.1
M18	5.6	2.0	88-100	119.2-136	1.5	100-117	136-158.5
	8.8		150-168	203.3-227.6		177-199	239.8-269.6
	10.9		175-194	237.1-262.9		202-231	273.7-313
M20	5.6	2.5	108-130	146.3-176.2	1.5	132-150	178.9-203.3
	8.8		186-205	252-277.8		206-242	279.1-327.9
	10.9		213-249	288.6-337.4		246-289	333.3-391.6