



FAST-CAST SERIES SPREADERS
Fast-Cast 2000 (p/n:1CS1)
Fast-Cast 300 (p/n:1CS9)
Fast-Cast 400 (p/n:1CS10)



Fast-Cast 300 (p/n:1CS9) Product Information	
Rock Salt, Deicers	4 to 20ft. Spreading Width
Light Duty Gr. Applications	7-10 Amperage Draw
3.0 Cu. ft. / 180lb. Capacity	

Fast-Cast 400 (p/n:1CS10) Product Information	
Fine Material Applications	4 to 20ft. Spreading Width
3.0 Cu. ft. / 180lb Capacity	7-10 Amperage Draw



Fast-Cast 2000 (p/n:1CS1) Product Information	
Rock Salt, Deicers	4 to 40ft. Spreading Width
Free-Flowing Materials	12-15 Amperage Draw
5.0 Cu. ft. / 350lb. Capacity	

The contents of this envelope are the property of the owner. Leave with the owner when installation is complete.

SAFETY INFORMATION

SAFETY DEFINITIONS:

! WARNING

Indicates a potentially hazardous situation that, if not avoided, could result in death or serious personal injury.

! CAUTION: Indicates a potentially hazardous situation that, if not avoided, may result in minor or moderate injury. It may also be used to alert against unsafe practices.

NOTE: Indicates a situation or action that can lead to damage of your spreader and vehicle or other property. Other useful information can also be described.

WARNING/CAUTION LABELS:

Please become familiar with the Warning and Caution labels on the spreader.

NOTE: If the labels are missing or cannot be read, see your sales outlet.

Label Locations for models 1CS9 and 1CS10:

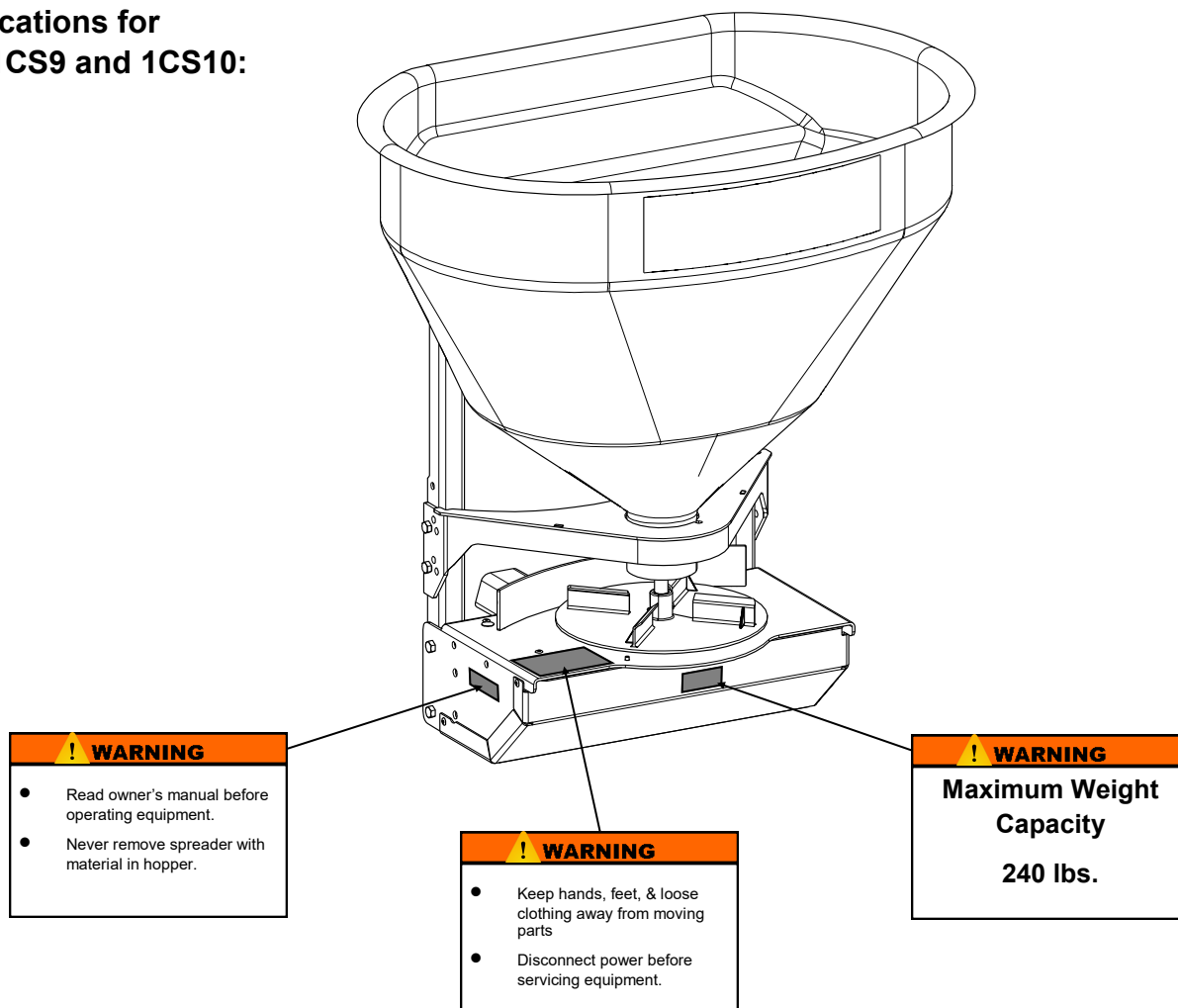

SAFETY INFORMATION

Label Locations for model 1CS1:

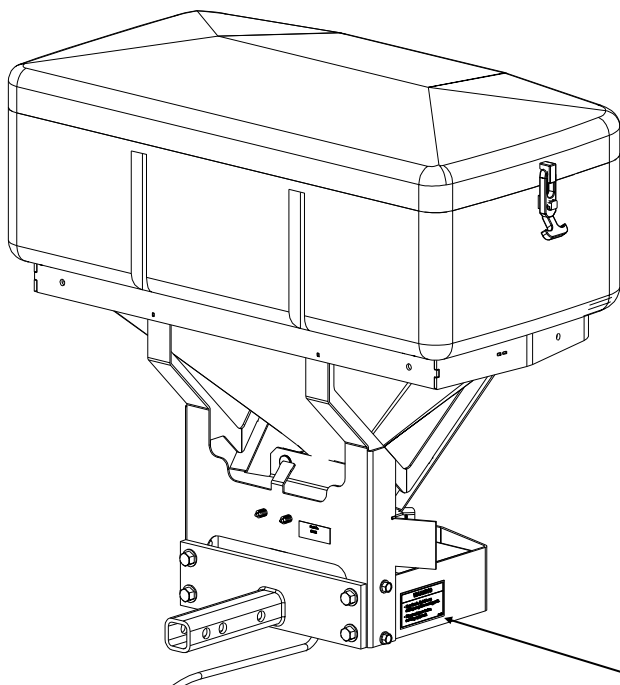

! WARNING

- Keep hands, feet, & loose clothing away from moving parts
- Disconnect power before servicing equipment.

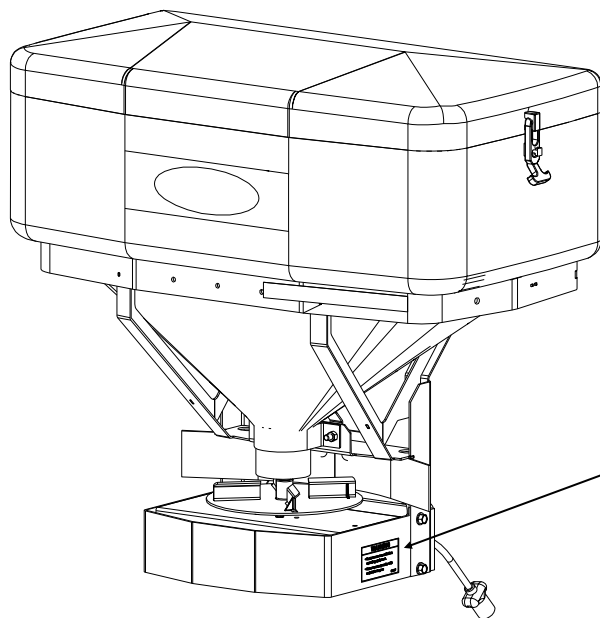

! WARNING

- Read owner's manual before operating equipment.
- Never remove spreader with material in hopper.

SAFETY INFORMATION

SERIAL NUMBER LABELS:

(NO SERIAL NUMBER ON 1CS1)

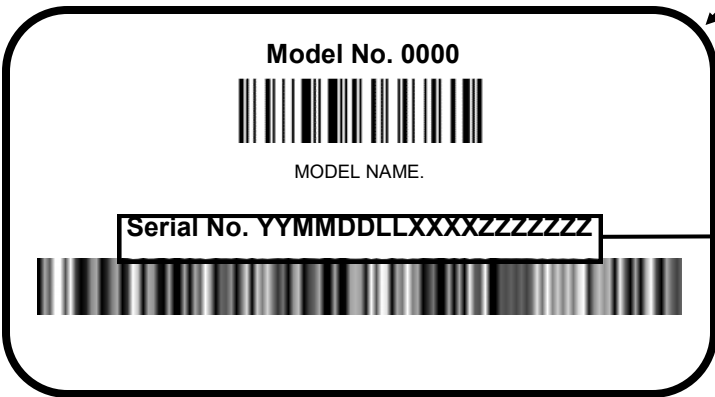
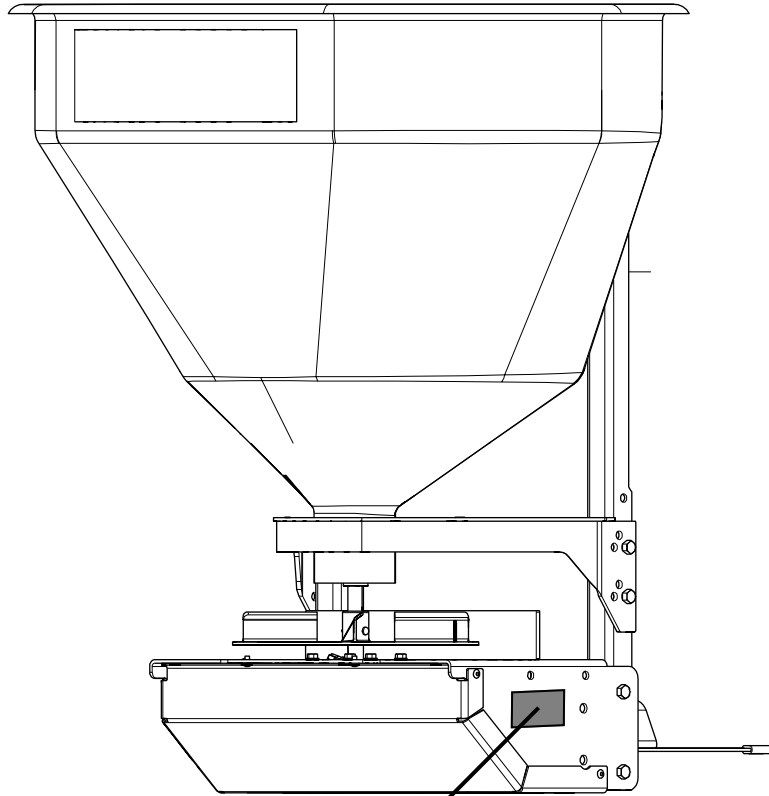

Code	Definition
YY	2-Digit Year
MM	2-Digit Month
DD	2-Digit Day
LL	2-Digit Location Code
XXXX	4-Digit Sequential Number
ZZZZZZ	Assembly Part Number

SAFETY INFORMATION

SAFETY PRECAUTIONS:

Improper installation and operation could cause personal injury and/or equipment and property damage. Read and understand labels and the Owner's Manual before installing, operating, or making adjustments.

WARNING

- Driver to keep bystanders a minimum of 25 feet away from operating spreader.
- Before working with the spreader, secure all loose-fitting clothing and unrestrained hair.
- Before operating the spreader, verify all safety guards are in place.
- Before servicing the spreader wait for auger and spinner to stop.
- Do not climb into or ride on spreader.

WARNING



Overloading could result in an accident or damage. Do not exceed GVWR or GAWR ratings as found on the driver-side door corner post of the vehicle. See Loading Section to determine maximum volumes of spreading material.



CAUTION: If rear directional, CHMSL light or brake stoplights are obstructed by the spreader, the lights shall be relocated, or auxiliary directional or brake stoplights shall be installed



CAUTION:

- Do not operate a spreader in need of maintenance.
- Before operating the spreader, reassemble any parts or hardware removed for cleaning or adjusting.
- Before operating the spreader, remove materials such as cleaning rags, brushes, and hand tools from the spreader.
- While operating the spreader, use auxiliary warning lights, except when prohibited by law.
- Tighten all fasteners according to the Torque Chart. Refer to Torque Chart for the Recommended torque values.



CAUTION: During the hopper spreader installation, we recommend the addition of an OSHA compliant Back-up Alarm. This alarm is required for OSHA governed employers.



CAUTION: DO NOT leave unused material in hopper. Material can freeze or solidify, causing unit to not work properly. Empty and clean after each use.



CAUTION: Disconnect electric and/or hydraulic power and tag out if required before servicing or performing maintenance.

NOTE: Lubricate grease fittings after each use. Use a good quality multipurpose grease

SAFETY INFORMATION

PERSONAL SAFETY:

- Remove ignition key and put the vehicle in park or in gear to prevent others from starting the vehicle during installation or service.
- Wear only snug-fitting clothing while working on your vehicle or spreader.
- Do not wear jewelry or a necktie, and secure long hair.
- Wear safety goggles to protect your eyes from battery acid, gasoline, dirt and dust.
- Avoid touching hot surfaces such as the engine, radiator hoses and exhaust pipes.
- Always have a fire extinguisher rated BC handy for flammable liquids and electrical fires.

FIRE AND EXPLOSION:



WARNING

Gasoline is highly flammable and gasoline vapor is explosive. Never smoke while working on vehicle. Keep all open flames away from gasoline tank and lines. Wipe up any spilled gasoline immediately.

Be careful when using gasoline. Do not use gasoline to clean parts. Store only in approved containers away from sources of heat or flame.

VENTILATION:



WARNING

Vehicle exhaust contains lethal fumes. Breathing these fumes, even in low concentrations, can cause death. Never operate a vehicle in an enclosed area without venting exhaust to the outside.

CELL PHONES:

A driver's first responsibility is the safe operation of the vehicle. The most important thing you can do to prevent a crash is to avoid distractions and pay attention to the road. Wait until it is safe to operate Mobile Communication Equipment such as cell phones, text messaging devices, pagers or two-way radios.

NOISES:

Airborne noise emission during use is below 70dB(A) for the spreader.

VIBRATION:

Operating snowplow vibration does not exceed 2.5 m/s² to the hand-arm or .5 m/s² to the whole body.

BATTERY SAFETY:



CAUTION: Batteries normally produce explosive gases which can cause personal injury. Therefore, do not allow flames, sparks or lit tobacco to come near the battery. When charging or working near a battery, always cover your face and protect your eyes, and also provide ventilation.

- **Batteries contain sulfuric acid which burns skin, eyes, and clothing.**
- **Disconnect the battery before removing or replacing any electrical components.**

LOADING

CERTIFICATION:

! WARNING

New untitled vehicle installation of a spreader requires National Highway Traffic Safety Administration altered vehicle certification labeling. Installer to verify that struck load of snow or ice control material does not exceed GVWR or GAWR rating label and complies with FMVSS.

TORQUE CHART:

! CAUTION: Read instructions before assembling. Fasteners should be finger tight until instructed to tighten according to torque chart. Use standard methods and practices when attaching spreader including proper personal protective safety equipment.

Torque chart can be found on the very last page of this manual.

APPROXIMATE MATERIAL WEIGHTS:

! WARNING

Overloading could result in an accident or damage. DO not exceed GVWR or GAWR as found on the driver-side corner post of vehicle.

! WARNING

Do not overload vehicle. Use chart below to calculate weight of material. Weights of material are an average of dry material.

! CAUTION: Never use wet materials or materials with foreign debris with any of these spreaders. These units are designed to handle dry, clean, and free flowing material.

! CAUTION: Read and adhere to manufacturer's ice-control material package labeling including Material Safety Data Sheet requirements.

Material	Density (lb/ft ³)
Rock Salt (Dry)	80-90

Weight of spreader and mount must be added to struck material weight to determine total spreader weight. Do not exceed maximum material capacity as shown on the safety label (see Safety Information section).

Use only bagged rock salt with the spreader. Other forms of spreading material are not compatible with the tailgate spreader.

NOTE: If spreader and ice control material loading is in doubt, weigh vehicle for compliance with vehicle ratings.

1CS9 AND 1SC10 ASSEMBLY INSTRUCTIONS

1. Assembly Instructions:

The spreader shall be installed according to instructions supplied. Your local outlet is trained to provide this service and service your spreader with factory original parts.

- 1.1 Place the drive assembly on a flat level surface. Attach the receiver mount to the drive assembly as shown in figure 1.1 using four 1/2" x 1-1/2" cap screws. Tighten the fasteners according to torque chart.

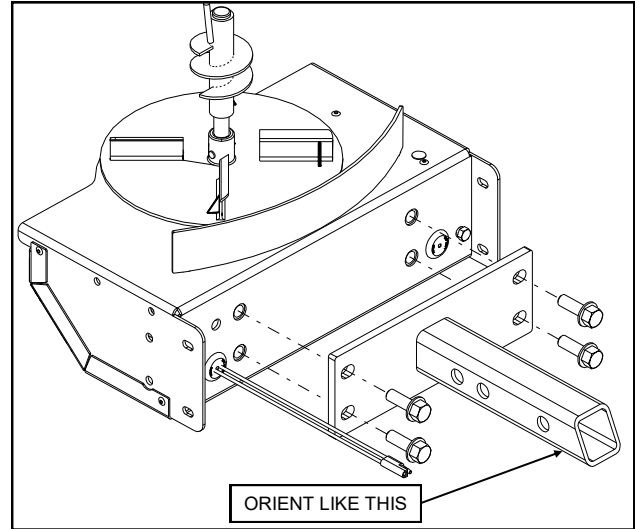

Fig 1.1

- 1.2 Mount the support frame to the drive assembly using the six supplied 5/16" x 1" cap screws and the four supplied 5/16" locknuts. Tighten the fasteners according to the torque chart. As shown in figure 1.2.

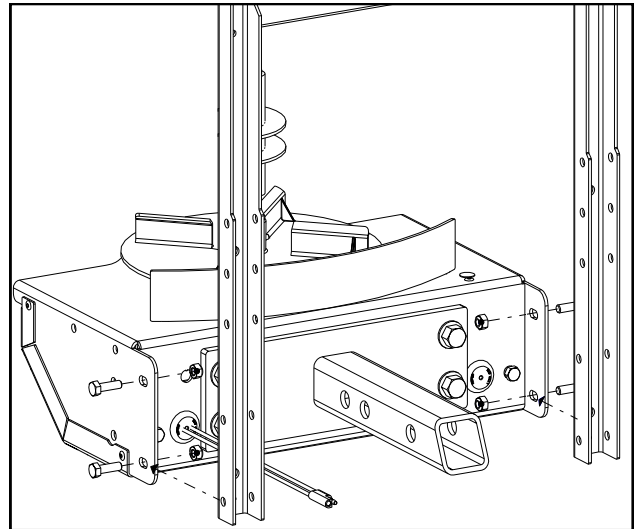

Fig 1.2

- 1.3 Mount the throat support to the support frame at the 2 lower holes by using the four supplied 5/16" x 1" cap screws and 5/16" locknuts. Tighten the fasteners according to the torque chart. As shown in figure 1.3.

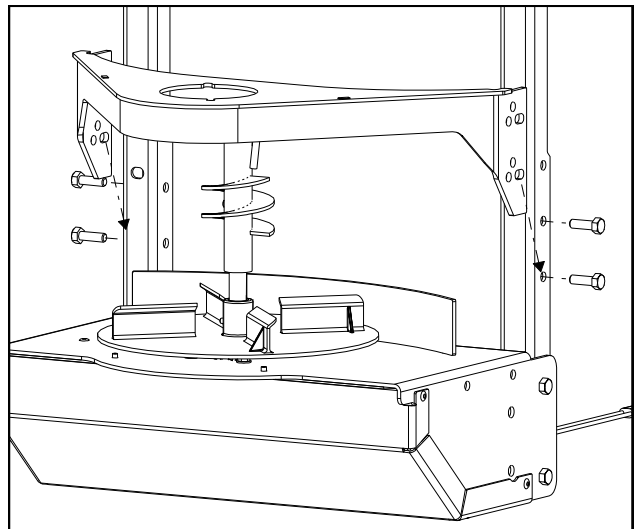

Fig 1.3

1CS9 AND 1SC10 ASSEMBLY INSTRUCTIONS

- 1.4 Drill four holes in the hopper using the support holes as a template. Place the backing plate inside the hopper. As shown in figure 1.4.

NOTE: Before drilling holes, check to be sure that no vehicle wiring or other components could be damaged.

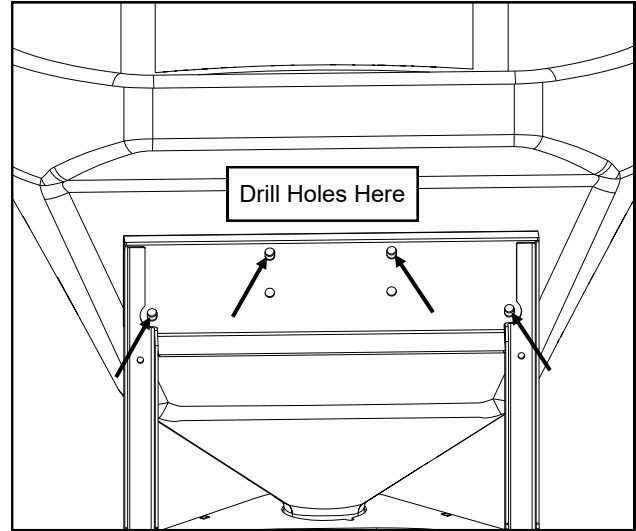

Fig 1.4

- 1.5 Fasten the hopper to the support frame by running the four supplied 5/16" x 1" cap screws through the backing plate, hopper and support frame from the inside of the hopper. Attach using the four supplied 5/16" lock nuts. Tighten the fasteners according to the torque chart. As shown in figure 1.5.

NOTE: Instructions on installing mount and wiring spreader are provided with vehicle specific mount.

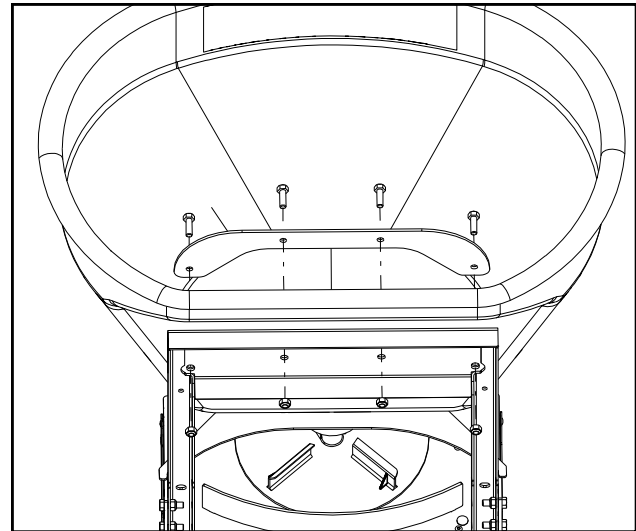

Fig 1.5

WIRING INSTRUCTIONS

- 2.1 The Harness Assembly will be routed from the rear of the vehicle to the front. Route Harness along frame and attach to frame holes and frame supports.

WARNING: It is not recommended to attach to fuel or brake lines for obvious reasons.

Do not route close to exhaust system or engine even though Curtis uses high temperature wiring, the wiring could still melt under extreme heat and short the spreader electrical system, as well as the vehicle electrical system.

- 2.2 Mount Rear Plug on bumper using supplied bolts. Locate towards the center of the bumper to reduce the amount of debris the tires will throw to the rear.

IMPORTANT: Apply a small amount of dielectric grease to the plug.

- 2.3 Secure Harness from the rear to the front using heaving duty tie-wraps or frame clips along the frame and lighter duty tie-wraps in all other locations.
- 2.4 Layout Harness portion that connects to the battery along the fire wall and fender well. Do not connect power leads to Battery at this time. Drill a 3/4" hole in the fire wall, or use existing access hole for the control portion of the Harness and route connector and Harness through hole. Be sure to check the area on the other side of the fire wall to be certain that you are not going to drill into the vehicle harness or a Control Module. Generally you can drill on either side of the steering wheel for a good location.
- 2.5 Connect Harness to the back of the Controller and mount to a suitable location.

NOTE: You may want to contact customer before mounting controller, some prefer not to have holes drilled into the dashboard.

Tie-wrap loose Controller Harness and move to the vehicle engine compartment.

- 2.6 Connect power leads to the **Battery: Red(+) Positive, Black(-) Negative**. Always connect to the primary Battery if using a Dual Battery System. Secure loose loom to any other large or medium vehicle harness with medium duty tie-wraps; this will secure wiring Harness.
- 2.7 Install ignition wire to an auxiliary circuit the is hot when the ignition key is turned to ON position. This wire is 60" long and has a female terminal attached to it. This wire will plug into back of Controller. This wire must be installed in order for Controller to operate.
- 2.8 Push the ON/OFF button on the Controller to check for power, when that has been confirmed turn power OFF. The electrical portion of the installation is complete.

NOTE: If adding an inline fuse, use a 35 amp slow blow fuse on Fast-Cast 2000 only.

See page 31 for illustrated parts list of Electrical Wire Harness.

OPERATING THE SPREADER

DRIVING AND SPREADING ON SNOW AND ICE:



CAUTION: Drinking and then driving or spreading is very dangerous. Your reflexes, perceptions, attentiveness and judgement can be affected by even a small amount of alcohol. You can have a serious or even fatal collision if you drive after drinking. Please do not drink then drive or spread ice-control materials

Follow your vehicle owner's manual instructions for driving in snow and ice conditions. Remember, when you drive on snow or ice, your wheels will not get good traction. You cannot accelerate as quickly, turning is more difficult, and you will need longer braking distance. Wet and hard packed snow or ice offer the worst tire traction. It is very easy to lose control. You will have difficulty accelerating. If you do get moving, you may have poor steering and difficult braking, which can cause you to slide out of control.

Here are some tips on driving in these conditions:

- Drive defensively
- Do not drink, then drive or spread ice-control materials.
- Spread or drive only when you have good visibility for operating a vehicle.
- If you cannot see well due to snow or icy conditions, you will need to slow down and keep more space between you and other vehicles.
- Slow down, especially on higher-speed roads. Your headlamps can light up only so much road ahead.
- If you are tired, pull off in a safe place and rest.
- The spreader's size and location reduce driver visibility to the rear of the vehicle. We recommend an OSHA compliant back up alarm for all governed employers.
- Keep your windshield and all glass on your vehicle clean to see around you.
- Dress properly for the weather. Wear layers of clothing: as you get warm, you can take off layers.

WARNING

Never allow children to operate or climb on equipment.

WARNING

Never operate equipment when under the influence of alcohol, drugs, or medications that might alter your judgement and/or reaction time.

WARNING

Never exceed 45 mph (72 km/h) when loaded spreader is attached to vehicle. Braking distances may be increased and handling characteristics may be impaired at speeds above 45 mph (72 km/h).

WARNING

Before starting the spreader, the driver shall verify that all bystanders are a minimum of 25 feet away from operating spreader.

MAINTENANCE

WARNING

Never remove the spreader with material in the hopper.

 **CAUTION:** Disconnect electric power at spreader electrical wiring harness connection and tag out if required before servicing or performing maintenance.

CAUTION:

- When replacing parts, use only original manufacturer's parts. Failure to do so will void warranty.
- The control is a solid state electronic unit and is not serviceable. Any attempt to service will void warranty.
- There are no serviceable parts in the motor/transmission assembly. Any attempt to service will void warranty.
- When pressure washing motor enclosure area, stay at least 36" away from motor enclosures.

LUBRICATION:

To keep your spreader running smoothly, observe the following recommendations.

- Lubricate bearings after 20 hours of use.
- Apply a small amount of light oil to latches as needed.

AFTER EACH USE:

 **CAUTION:** DO NOT leave unused material in hopper . Material can freeze or solidify, causing unit to not work properly. Empty and clean after each use.

- Wash out the hopper and rinse off all external surfaces.
- Apply dielectric grease on all electrical connections to prevent corrosion.

AT THE END OF EACH SEASON OR AFTER EXTENDED STORAGE:

- Wash out the hopper and rinse off all external surfaces.
- Apply dielectric grease on all electrical connections to prevent corrosion.
- Lubricate all grease fittings with good quality multipurpose grease.
- Oil or paint all bare metal surfaces.
- If motor cover is removed for any reason, use silicone sealant to ensure weather proofing of enclosures

STORAGE:

Store the spreader in a clean, dry location and away from direct sunlight.

TROUBLESHOOTING

TAILGATE SPREADER: 1CS1

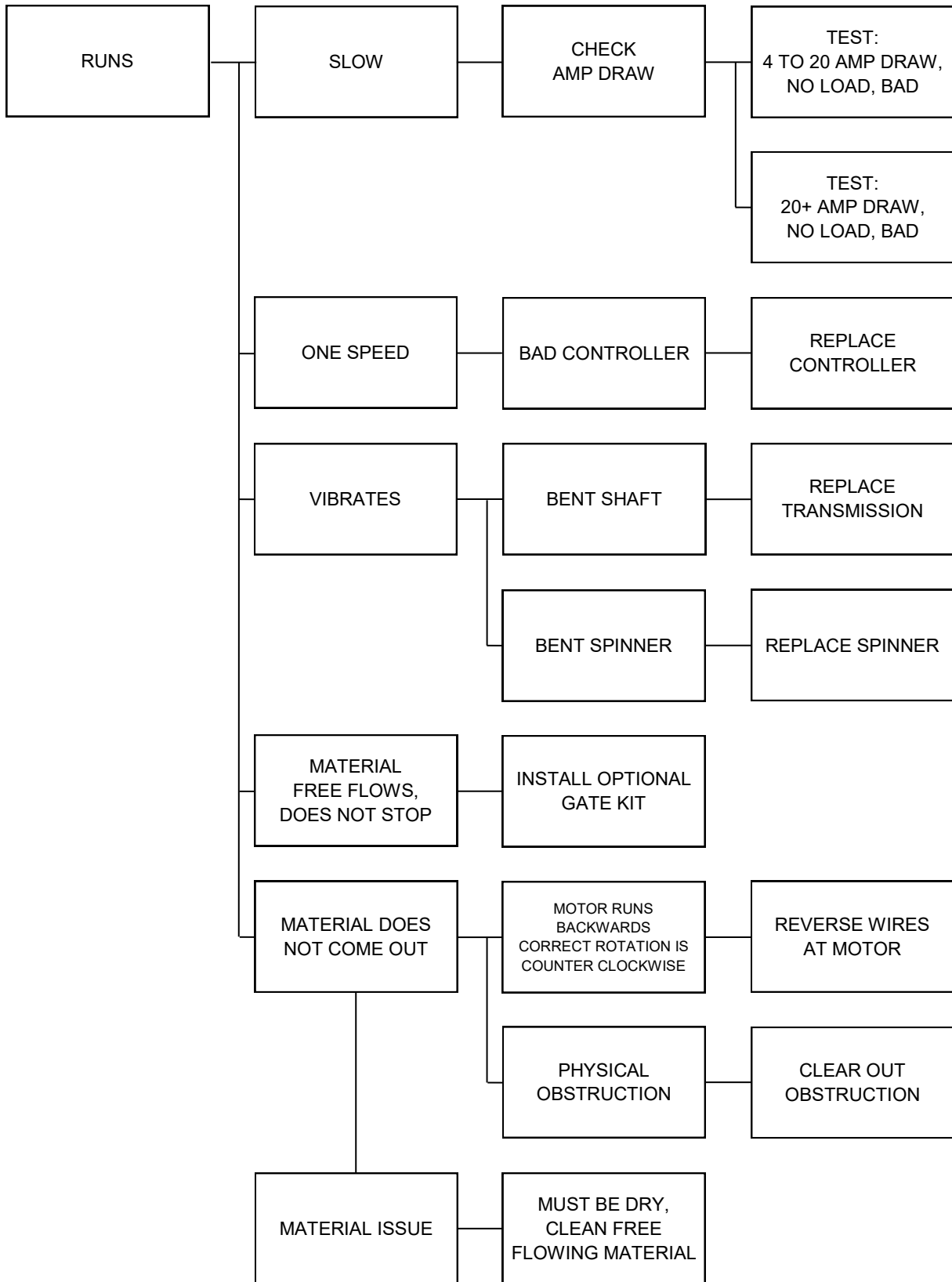

TROUBLESHOOTING

TAILGATE SPREADER: 1CS9 AND 1CS10

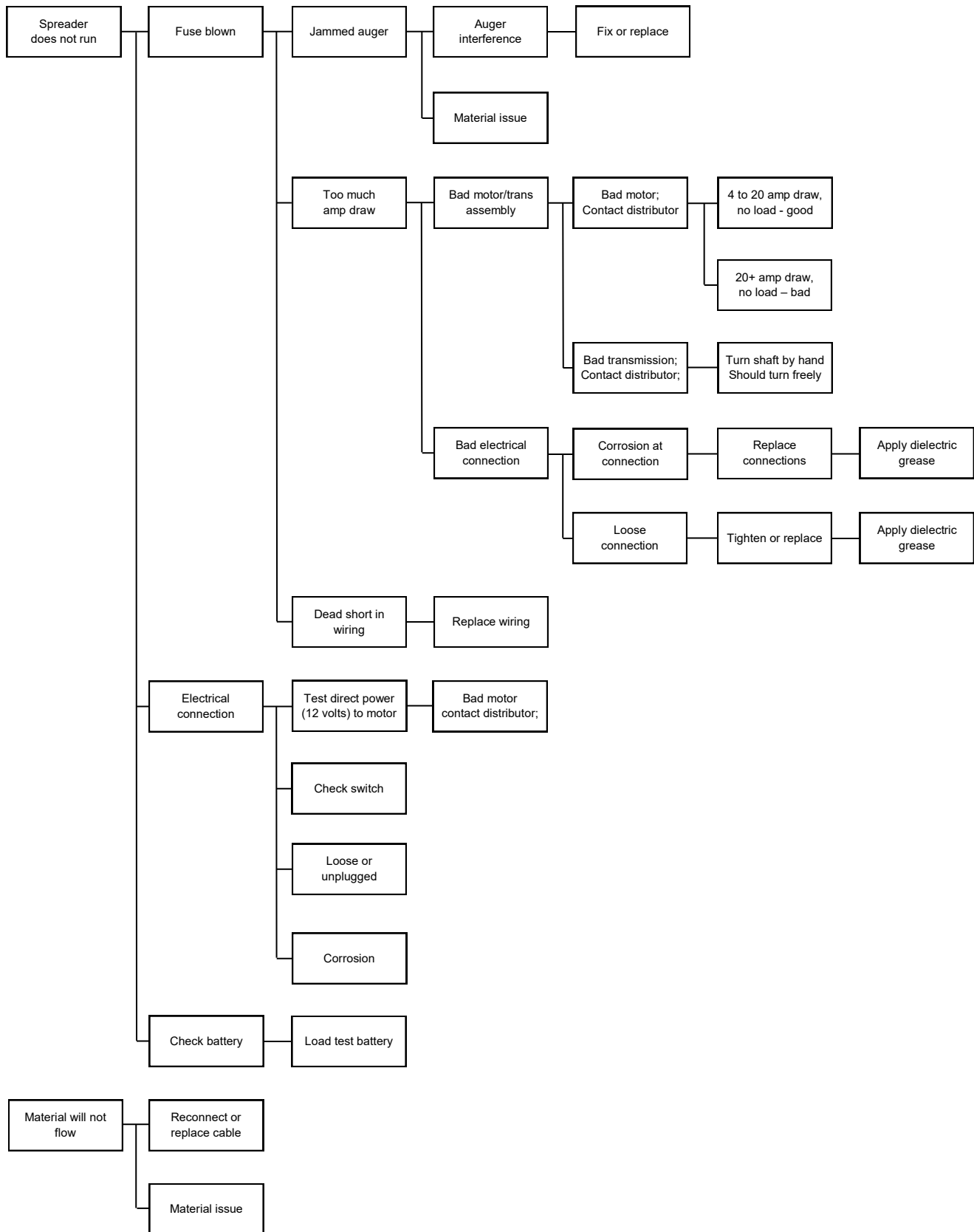

1CS1 - HOPPER COMPONENTS

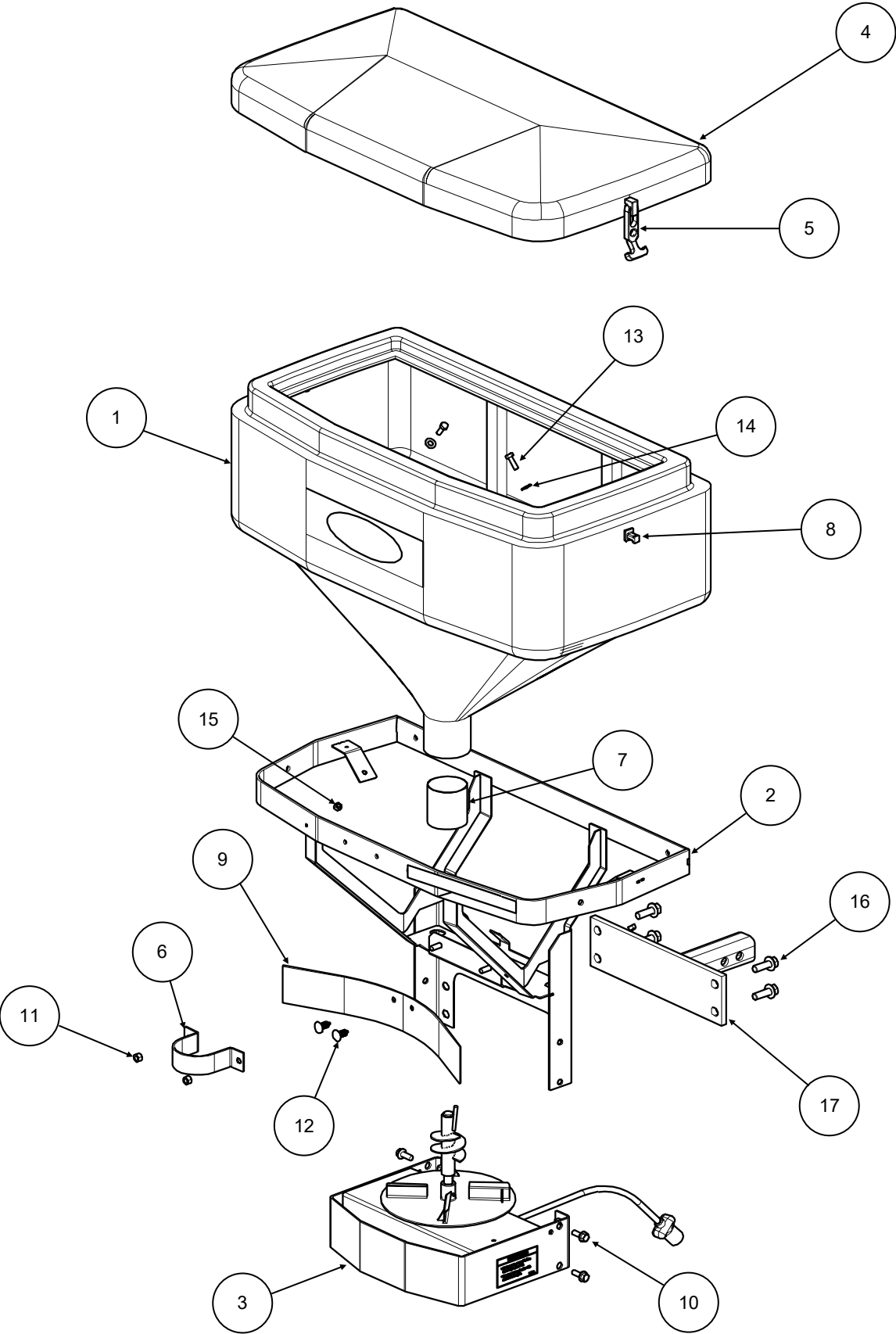

1CS1 - HOPPER COMPONENTS

PARTS LIST:			
ITEM NO.	PART NO.	DESCRIPTION.	QTY.
1	1CS1P3	HOPPER	1
2	1CS1P4	MAIN FRAME	1
3	1CS1P49	DRIVE ASSEMBLY	1
4	1CS1P1	LID WITH LATCHES	1
5	1CS1P2	FLEXIBLE DRAW LATCH	2
6	1CS1P5	THROAT CLAMP	1
7	1CS1P42	STAINLESS THROAT LINER	1
8	1CS1P48	LATCH KEEPER	2
9	1CS1P12	DEFLECTOR 20"	1
10	1CS1P8	3/8"-16 X 1" HEX BOLT	4
NS	O.L.	3/8"-16 LOCK NUT	4
11	1CS1P9	3/8"-16 SERRATED FLANGE NUT	2
12	O.L.	DEFLECTOR PUSH FASTENER	2
13	1CS1P6	5/16"-18 X 1-1/4" PHILLIPS BOLT	2
14	1CS1P47	3/8" S/S WASHER	2
15	1CS1P7	5/16"-18 HEX NUT	4
16	1CS1P10	1/2"-13 X 1-1/2" HEX BOLT	8
17	1SM2P1	2" RECEIVER HITCH	1
NS	1SM1P2	5/8" X 5-1/2" HITCH PIN	1
NS	1SM1P3	2-5/16" HAIR PIN CLIP	1

* O.L. = Obtain Locally

NS = Not Shown

1CS1 - DRIVE ASSEMBLY

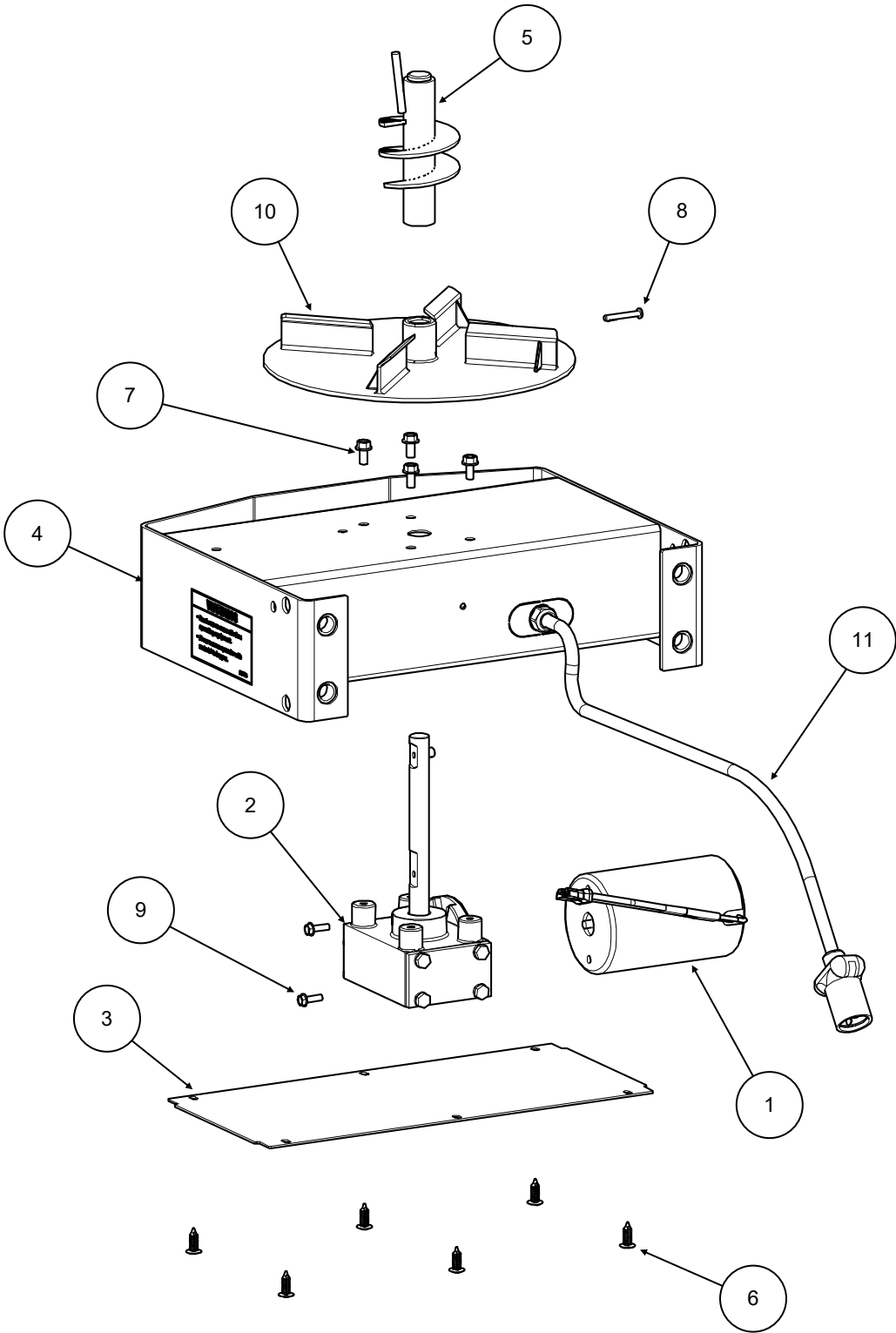

PARTS LIST LOCATED ON FOLLOWING PAGE.

1CS1 - DRIVE ASSEMBLY

PARTS LIST:

ITEM NO.	PART NO.	DESCRIPTION	QTY.
1	1CS1P16	MOTOR 12 VOLT DC	1
2	1CS1P53	TRANSMISSION	1
3	1CS1P17	MOTOR COVER	1
4	1CS1P13	DRIVE ENCLOSURE	1
5	1CS1P19	AUGER	1
6	1CS1P29	3/16" ALUMINUM RIVET	6
7	1CS1P25	1/4"-20 X 3/4" HEX BOLT	4
8	1CS1P24	5/16"-18 X 1/2" HEX BOLT	1
9	1CS1P27	#10-32 X 5/8" CAP SCREW	2
10	1CS1P18A	10" STEEL SPINNER	1
11	1CS1P21	FAST CAST 2000 POWER CABLE	1

1CS9 - HOPPER COMPONENTS

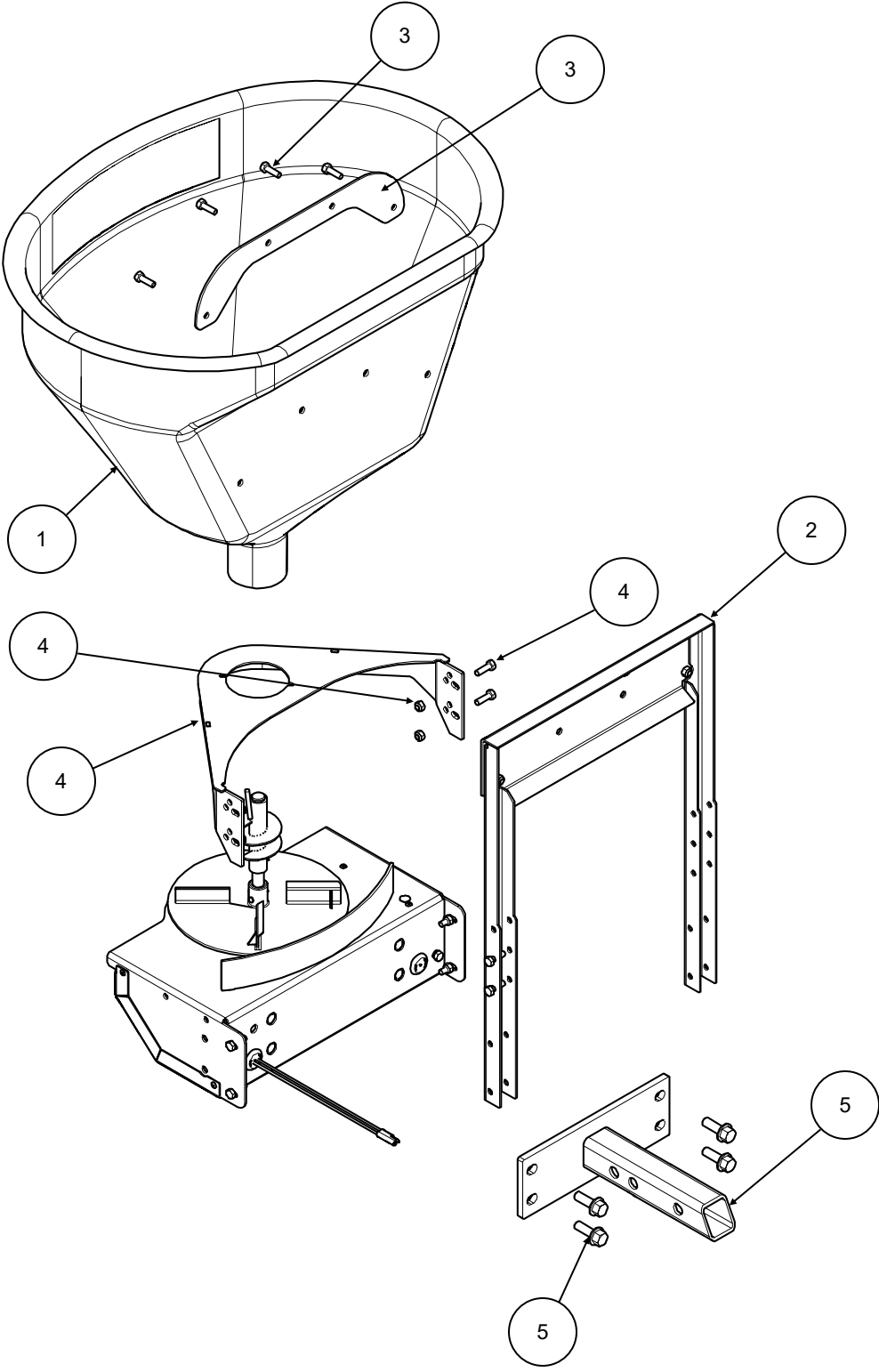

PARTS LIST LOCATED ON FOLLOWING PAGE.

1CS9 - HOPPER COMPONENTS

PARTS LIST:			
ITEM NO.	PART NO.	DESCRIPTION.	QTY.
1	1CS9P1	HOPPER, SR-210, GREY	1
2	1CS9P10	HOPPER FRAME	1
3	1CS9P9	HOPPER SUPPORT KIT	1
4	1CS9P11	SALTER THROAT DECK	1
5	1SM2	RECEIVER KIT	1
NS	1SM1P2	5/8 X 5-1/2 HITCH PIN W/ HAIRPIN COTTER	1
NS	1SM1P3	2-5/16" HAIR PIN CLIP	1
NS	-	FCC COMPLIANCE LABEL KIT	1

* O.L. = Obtain Locally

NS = Not Shown

1CS9 - DRIVE ASSEMBLY

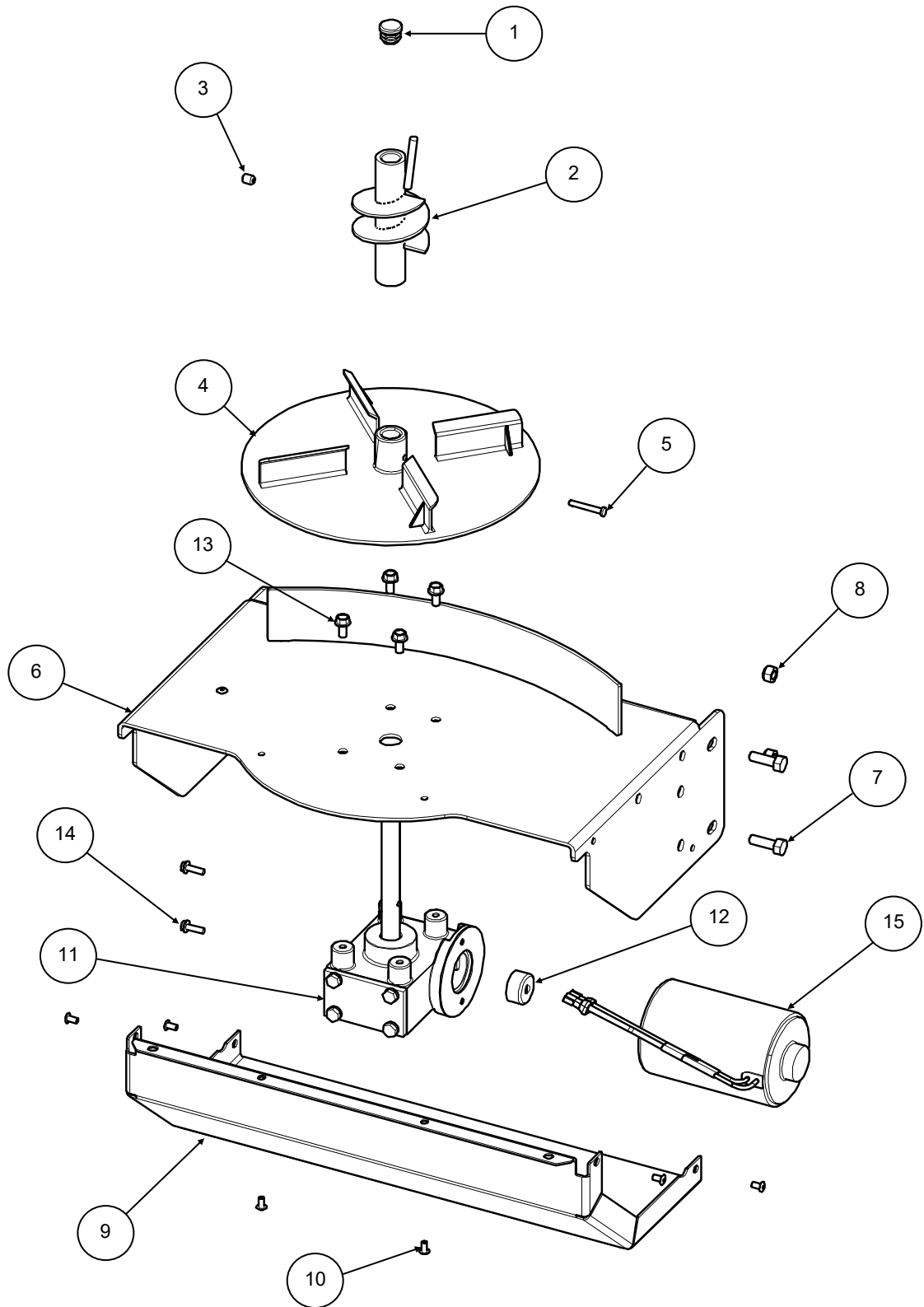

PARTS LIST LOCATED ON FOLLOWING PAGE.

1CS9 - DRIVE ASSEMBLY

PARTS LIST:			
ITEM NO.	PART NO.	DESCRIPTION	QTY.
1	1CS9P8	AUGER CAP	1
2	1CS1P19	AUGER	1
3	1CS1P23	5/16-18 X 3/8 SET SCREW	1
4	1CS1P18	SPINNER, POLY	1
5	O.L.	3/16 X 1-1/4 CLEVIS PIN	1
6	1CS10P8	TRANSMISSION MOUNT	1
7	O.L.	5/16-18 X 1 HEX CAP SCREW SERRATED	6
8	1SM5P1	5/16-18 SERREATED FLANGE NUT	4
9	1CS10P9	TRANSMISSION ENCLOSURE COVER	1
10	1CS10P10	RIVET 3/16 X .354	6
11	1CS9P5	TRANSMISSION 14.5:1	1
12	1CS1P51	MOTOR DRIVE COUPLER	1
13	1CS1P25	1/4-20 X 1/2 SERRATED FLANGE SS BOLT	4
14	1CS1P27	10-32 X 5/8 HEX CAP SCREW SERRATED	2
15	1CS2P10	3 X 3.8 12V DC MOTOR	1
NS	-	LABEL, WARNING—HANDS & FEET	1
NS	-	LABEL, WARNING—MAXIMUM WEIGHT	1
NS	-	LABEL, WARNING—READ MANUAL	

* O.L. = Obtain Locally

NS = Not Shown

1CS10 - HOPPER COMPONENTS

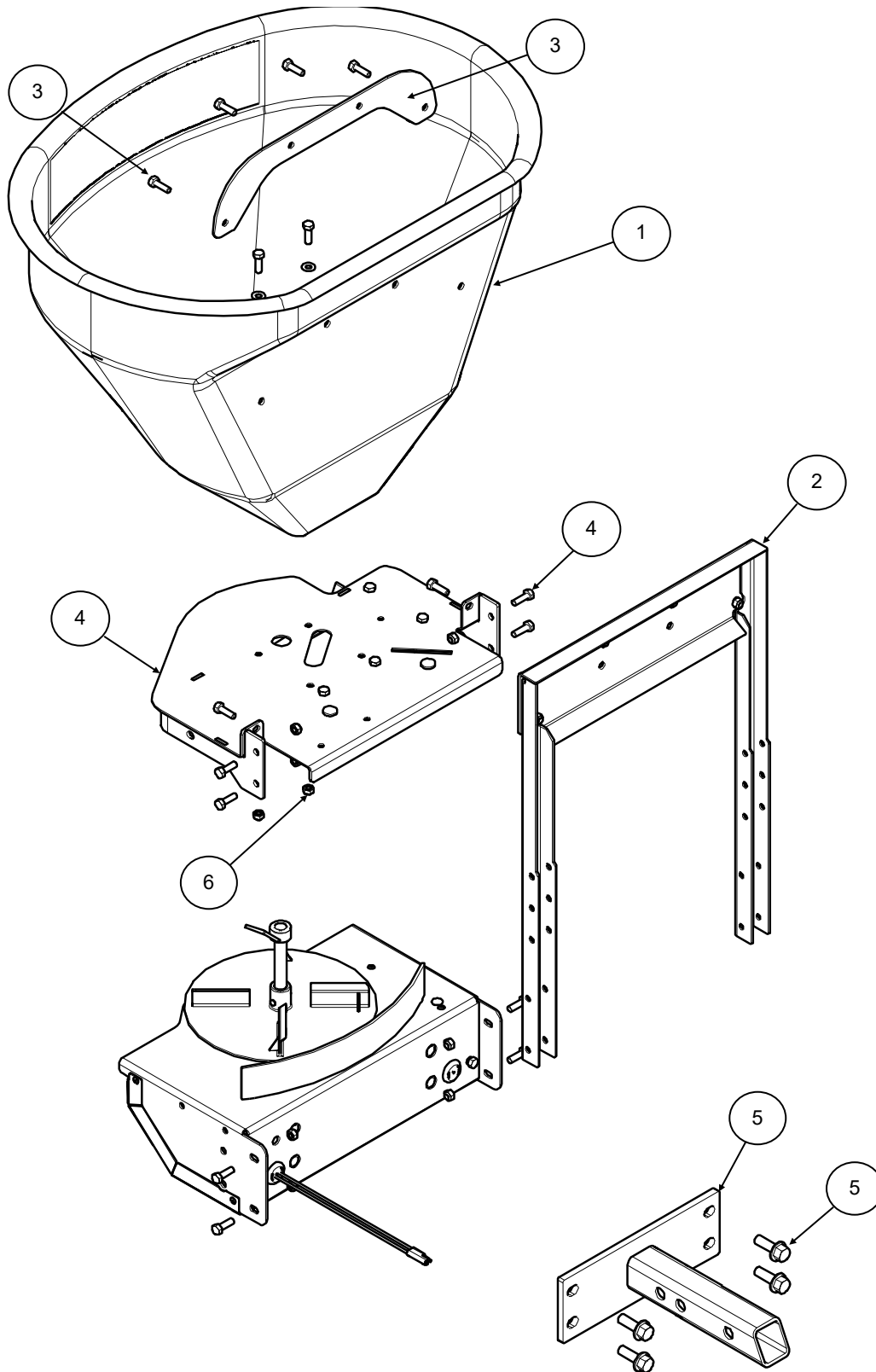

PARTS LIST LOCATED ON FOLLOWING PAGE.

1CS10 - HOPPER COMPONENTS

PARTS LIST:

ITEM NO.	PART NO.	DESCRIPTION.	QTY.
1	1CS9P1	HOPPER, SR-210, GREY	1
2	1CS9P10	HOPPER FRAME	1
3	1CS10P7	HOPPER SUPPORT KIT	1
4	1CS10P11	GATE DECK	1
5	1SM2	RECEIVER KIT	1
NS	1SM1P2	5/8 X 5-1/2 HITCH PIN	1
NS	1SM1P3	2-5/16" HAIR PIN CLIP	1
NS	-	FCC COMPLIANCE LABEL KIT	1

* O.L. = Obtain Locally

NS = Not Shown

1CS10 - DRIVE ASSEMBLY

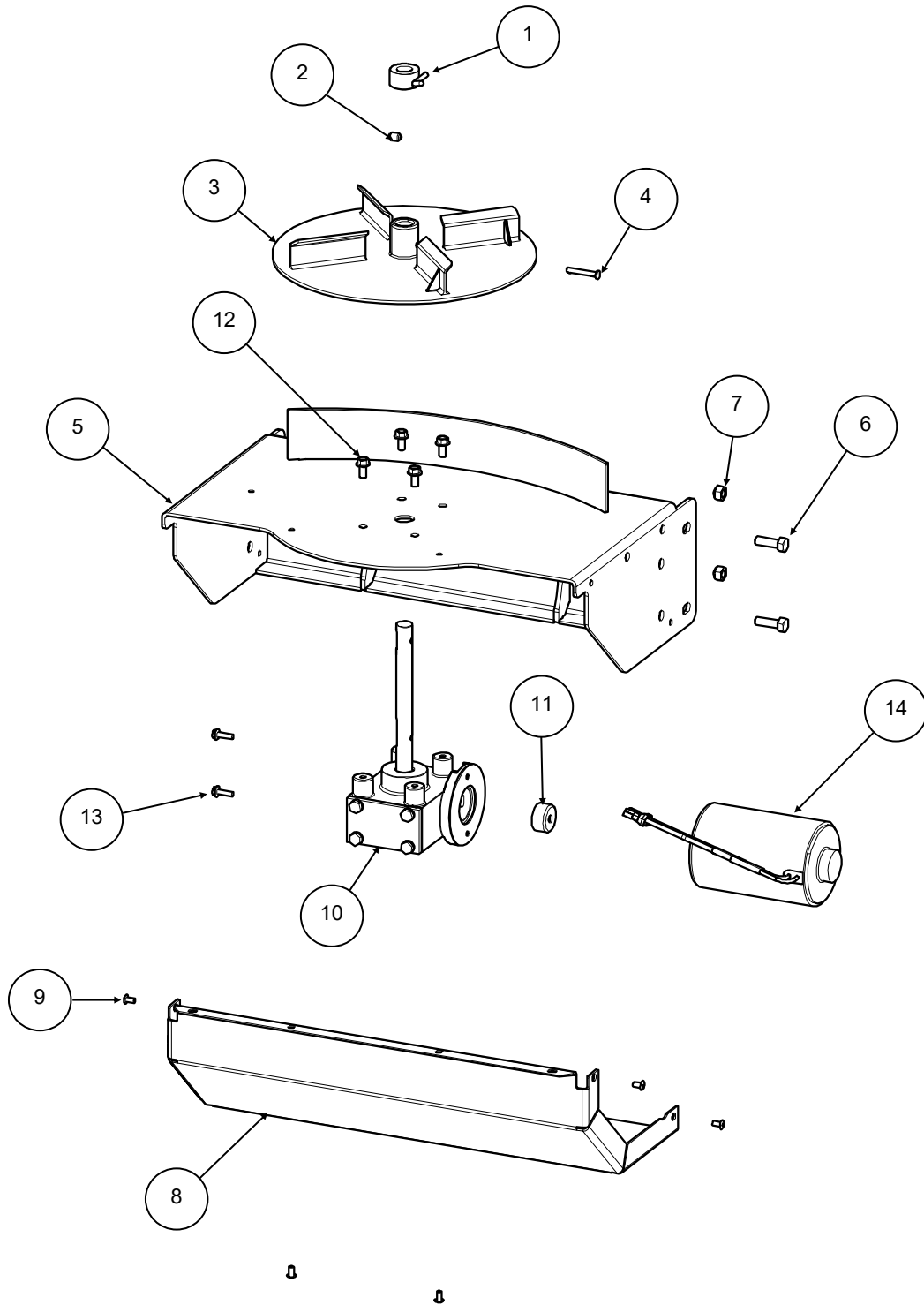

PARTS LIST LOCATED ON FOLLOWING PAGE.

1CS10 - DRIVE ASSEMBLY

PARTS LIST:			
ITEM NO.	PART NO.	DESCRIPTION	QTY.
1	1CS2P7	AGITATOR	1
2	1CSP23	5/16-18 X 3/8 SET SCREW	1
3	1CS1P18	SPINNER, POLY	1
4	O.L.	3/16 X 1-1/4 CLEVIS PIN	1
5	1CS10P8	TRANSMISSION MOUNT	1
6	O.L.	5/16-18 X 1 HEX CAP SCREW SERRATED	6
7	1CS1P7	5/16-18 SERRATED FLANGE NUT	4
8	1CS10P9	TRANSMISSION ENCLOSURE COVER	1
9	1CS10P10	RIVET 3/16 X .354	6
10	1CS9P5	TRANSMISSION 14.5:1	1
11	1CS1P51	MOTOR DRIVE COUPLER	1
12	1CS1P25	1/4-20 X 1/2 SERRATED FLANGE SS BOLT	4
13	1CS1P27	10-32 X 5/8 HEX CAP SCREW SERRATED	2
14	1CS2P10	3 X 3.8 12V DC MOTOR	1
NS	-	LABEL, WARNING — HANDS & FEET	1
NS	-	LABEL WARNING — MAXIMUM WEIGHT	1
NS	-	LABEL, WARNING -READ MANUAL	1

* O.L. = Obtain Locally

NS = Not Shown

1CS10 - GATE ASSEMBLY

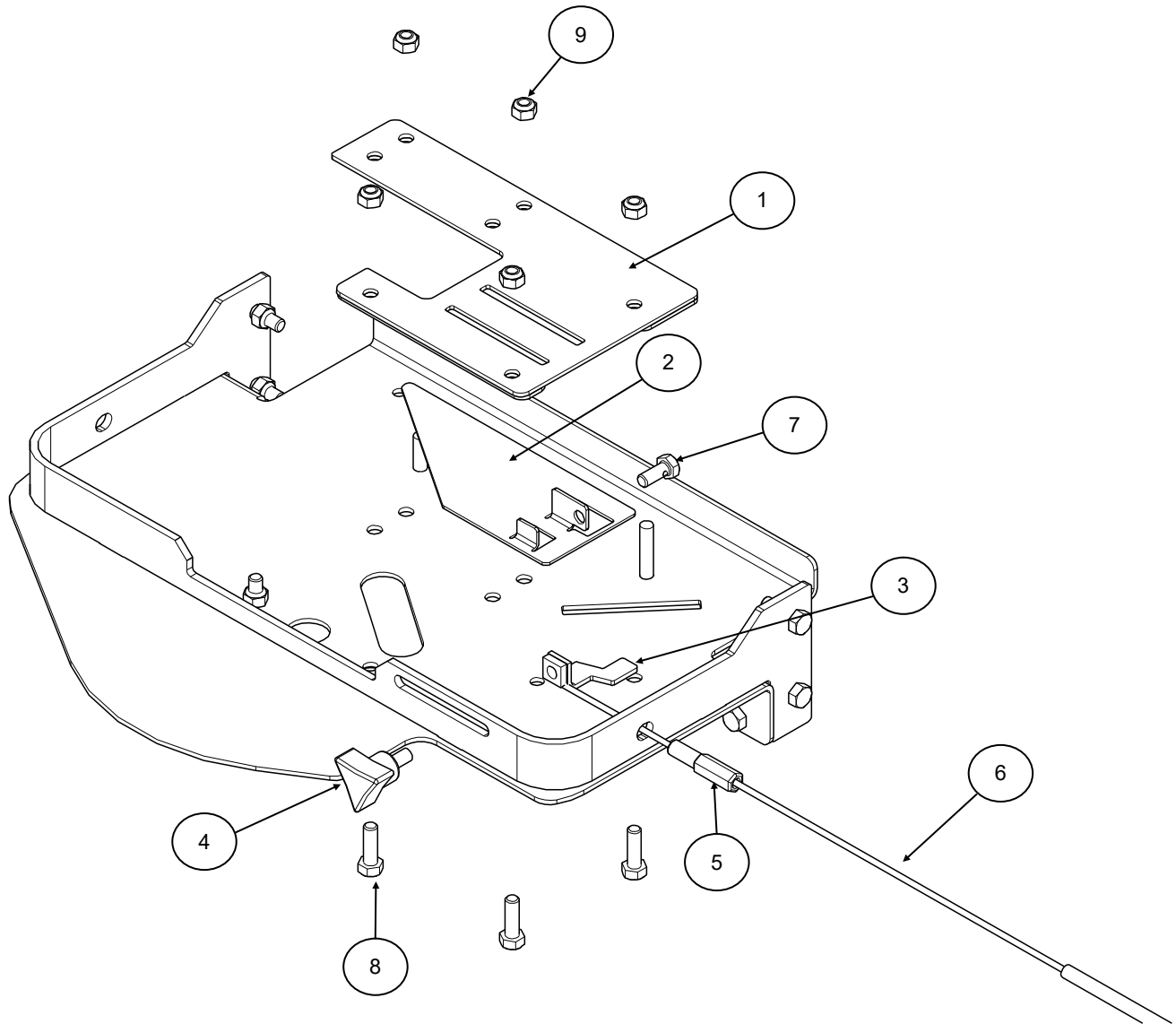

PARTS LIST:

ITEM NO.	PART NO.	DESCRIPTION.	QTY.
1	1CS10P4	FAST-CAST 400 GATE TRACK	1
2	1CS10P3	FAST-CAST 400 GATE SLIDE	1
3	1CS10P5	GATE INDICATOR / STOP	1
4	1CS10P6	GATE KNOB	1
5	1CS2P16	BULKHEAD CABLE FITTING	1
6	1GC1A	T-HANDLE CABLE - 20'	1
7	1CS2P17	5/16-18 X 3/4 BOLT W/ HOLE	1
8	O.L.	5/16-18 x 1 SERRATED CAP SCREW	6
9	1CS1P7	5/16-18 LOCKNUT	6

* O.L. = Obtain Locally

1SM4 Drop Utility Hitch for Fast-Cast 300 and 400 - Illustrated Parts List

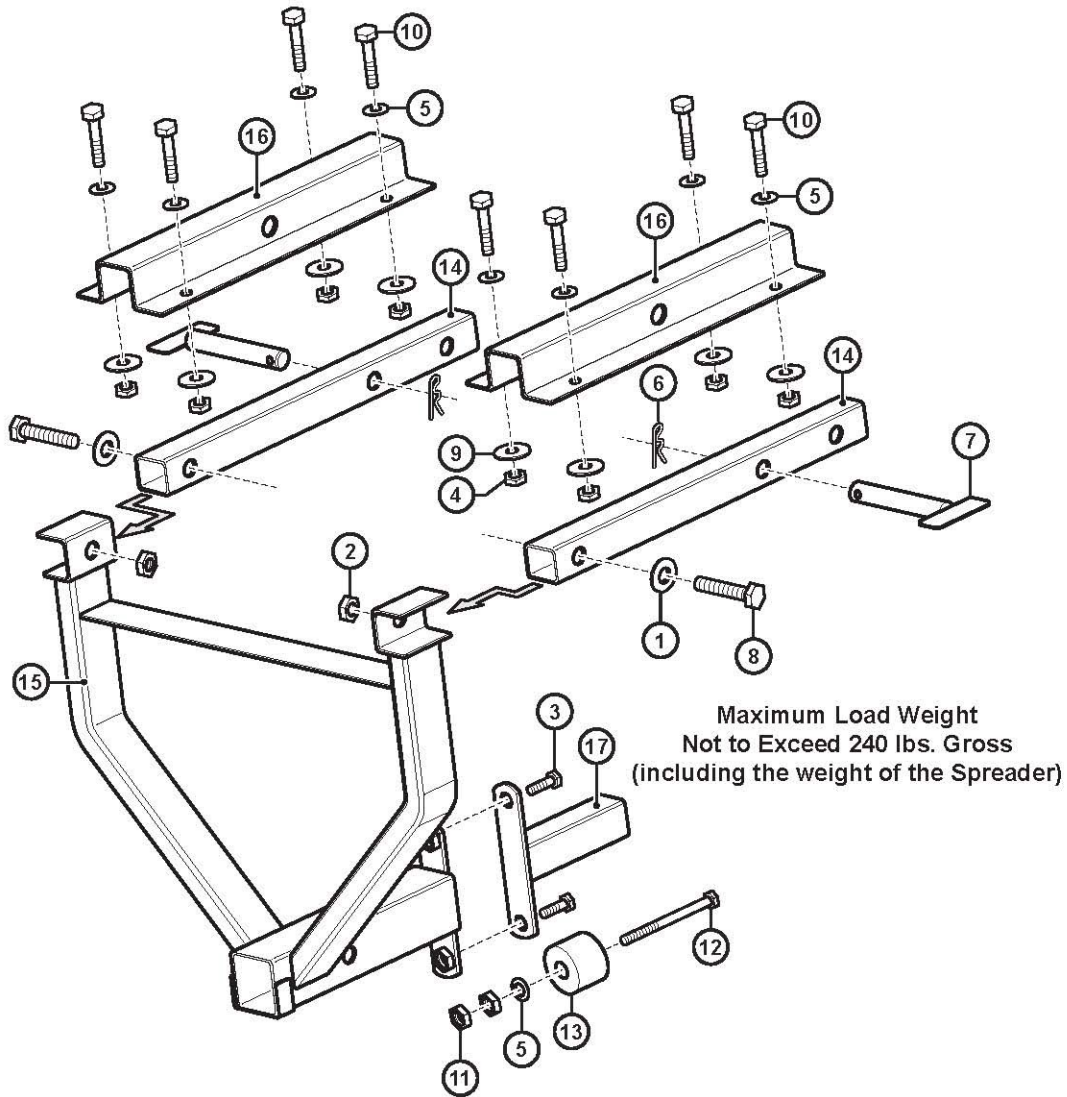

Item No.	Part No.	Description	Qty.
1	1SM3P4	1/2" Flat Washer	2
2	1CS1P11	1/2"-13 Lock Nut	2
3	1CS1P8	3/8"-16 x 1" Hex Bolt	2
4	1CS1P9	3/8"-16 Lock Nut	8
5	1CS1P41	3/8" Flat Washer	9
6	1SM1P3	2-5/16" Hair Pin Clip	2
7	1SM1P2	5/8" x 5-1/2" Hitch Pin	2
8	1SM4P10	1/2"-13 x 2" Hex Bolt	2

Item No.	Part No.	Description	Qty.
9	1CS2P15	3/8" Fender Washer	8
10	1SM4P2	3/8"-16 x 2" Truss Bolt	8
11	1SM4P3	3/8"-16 Hex Nut	2
12	1SM4P4	3/8"-16 x 5" Hex Bolt	1
13	1SM4P5	2" Rubber Stopper	1
14	1SM4P9	Mounting Rail	2
15	1SM4P6	Drop Mount Weldment	1
16	1SM4P7	Mounting Rail Hat Section	2
17	1SM4P8	Mule Adapter	1

1SM3 3-Point Tractor Mount - Illustrated Parts List

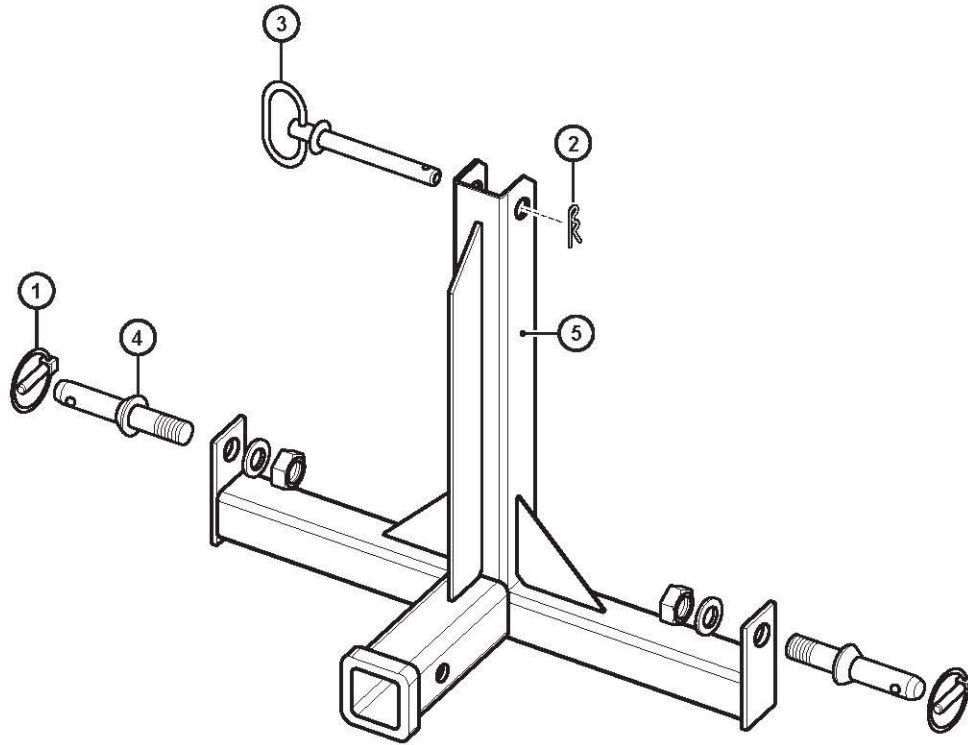

Item No.	Part No.	Description	Qty.
1	1SM1P7	5/16" Linch Pin	2
2	1SM1P3	2-5/16" Hairpin Clip	1
3	1SM1P2	5/8" x 5-1/2" Hitch Pin	1
4	1SM1P6	7/8" x 5-1/2" Lift Arm Pin	2
5	1SM1P1	3-Point Frame	1

Fast-Cast Spreader Optional Accessories

1AD1 - Adjustable Deflector (Controls Spread Pattern)

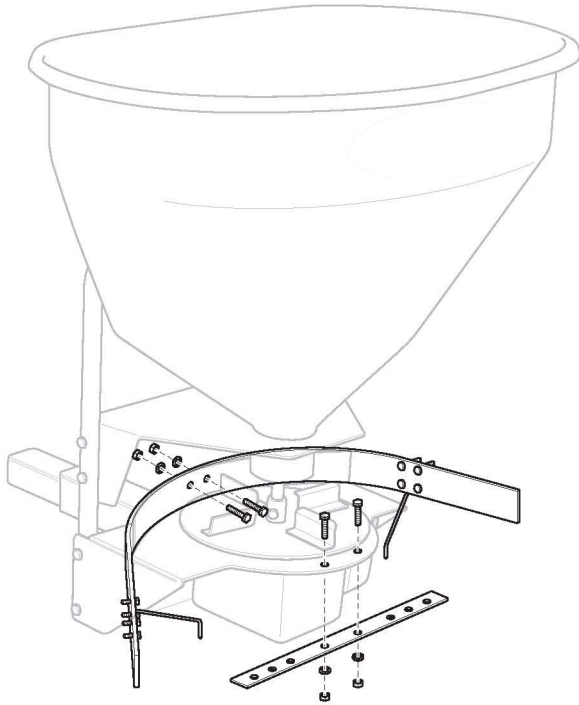

1GC1 - Gate Flow Control Kit for Fast-Cast 2000

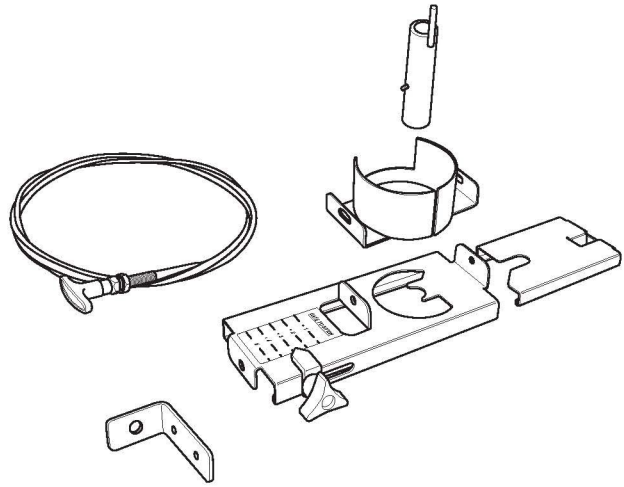

1SC3 - Variable Speed Control for Fast-Cast 300 or 400

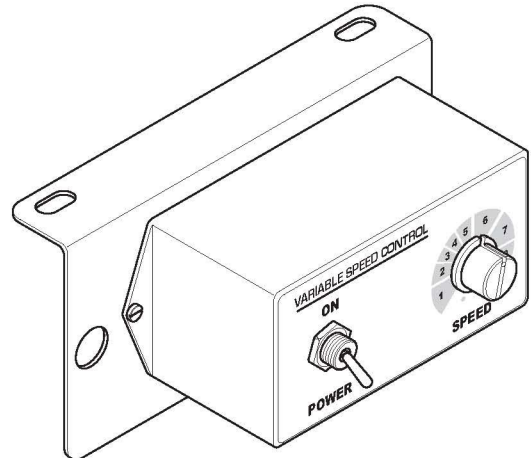

1WC3 - Weather Cover for Fast-Cast 300 or 400



1SM2 - 2" Light Duty Receiver Mount (Required for all Fast-Cast 2000 Installations)

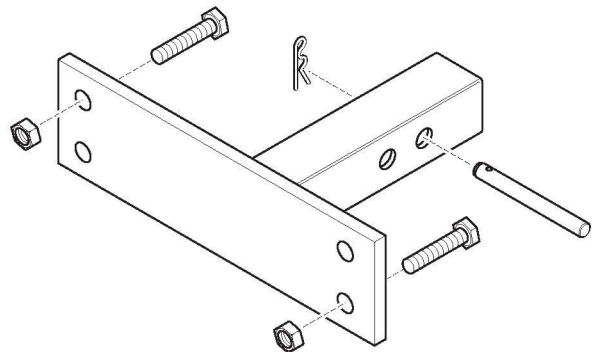

Wiring Harness for Fast-Cast 300 and 400 Spreaders - Illustrated Parts List

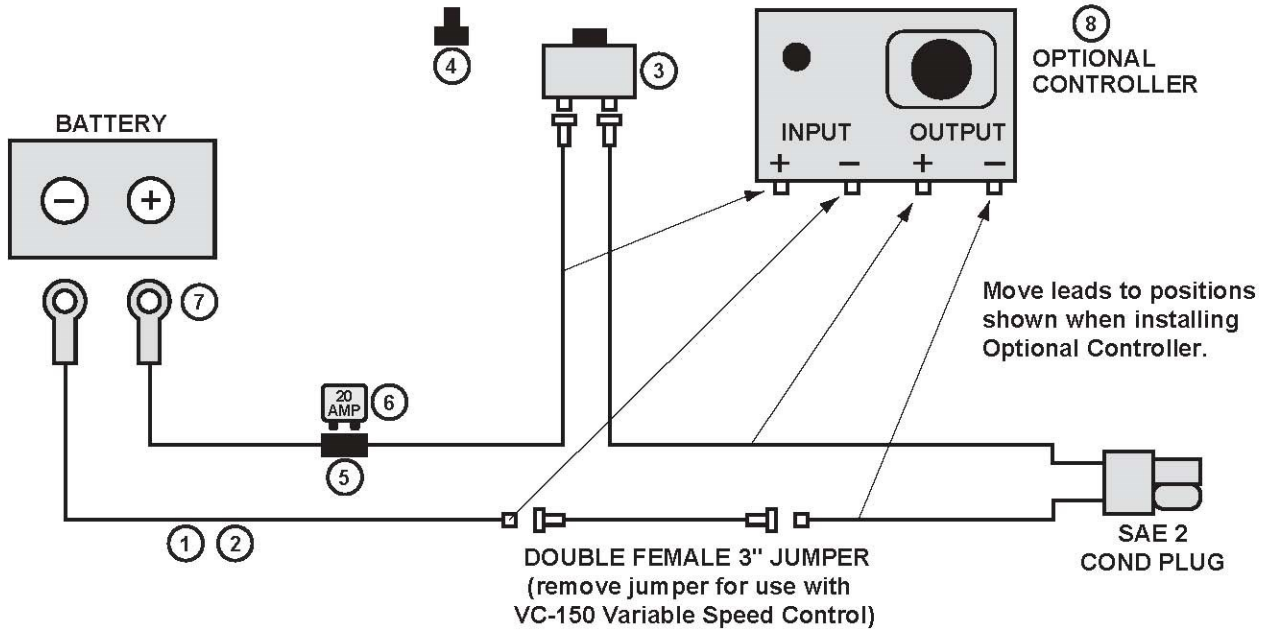

Item No.	Part No.	Description	Qty.
1	1CS2P27	Wiring Harness for Fast-Cast 300	1
2	1CS2P27	Wiring Harness for Fast-Cast 400	1
3	1CS2P25	On / Off Switch	1
4	1CS2P29	Rubber Switch Boot	1

Item No.	Part No.	Description	Qty.
5	1CS2P33	Fuse Holder	1
6	1CS9P7	20 Amp Mini-Fuse	1
7	1CS2P34	3/8" Ring Terminal	2
8	1SC3	Optional Variable Speed Controller	1



BOLT TORQUE

BOLT TORQUE SPECIFICATIONS

GENERAL TORQUE SPECIFICATION TABLE

Use the following torques when special torques are not given. These values apply to fasteners as received from suppliers, dry, or when lubricated with normal engine oil. They do not apply if special graphited or moly disulphide greases or other extreme pressure lubricants are used. This applies to both UNF and UNC threads. Remember to always use grade five or better when replacing bolts.

IMPORTANT: On all PLATED GRADE 8 bolts, reduce torque 15% from listed bolt torque specification.

SAE Grade No.		2				5				8*			
Bolt head identification mark as per grade. NOTE: Manufacturing Marks Will Vary													
		TORQUE		TORQUE		TORQUE		TORQUE		TORQUE		TORQUE	
Bolt Size		Pounds Feet		Newton-Meters		Pounds Feet		Newton-Meters		Pounds Feet		Newton-Meters	
Inches	Millimeters	Min.	Max.	Min.	Max.	Min.	Max.	Min.	Max.	Min.	Max.	Min.	Max.
1/4	6.35	5	6	7	8	9	11	12	15	12	15	16	20
5/16	7.94	10	12	14	16	17	20.5	23	28	24	29	33	39
3/8	9.53	20	23	27	31	35	42	48	57	45	54	61	73
7/16	11.11	30	35	41	47	54	64	73	87	70	84	95	114
1/2	12.70	45	52	61	70	80	96	109	130	110	132	149	179
9/16	14.29	65	75	88	102	110	132	149	179	160	192	217	260
5/8	15.88	95	105	129	142	150	180	203	244	220	264	298	358
3/4	19.05	150	185	203	251	270	324	366	439	380	456	515	618
7/8	22.23	160	200	217	271	400	480	542	651	600	720	814	976
1	25.40	250	300	339	406	580	696	787	944	900	1080	1220	1464
1-1/8	25.58	-	-	-	-	800	880	1085	1193	1280	1440	1736	1953
1-1/4	31.75	-	-	-	-	1120	1240	1519	1681	1820	2000	2468	2712
1-3/8	34.93	-	-	-	-	1460	1680	1980	2278	2380	2720	3227	3688
1-1/2	38.10	-	-	-	-	1940	2200	2631	2983	3160	3560	4285	4827

*Thick Nuts must be used with Grade 8 bolts

METRIC BOLT TORQUE SPECIFICATIONS



Size of Screw	Property Class	Course Thread			Fine Thread		
		Pitch (mm)	Pounds Feet	Newton-Meters	Pitch (mm)	Pounds Feet	Newton-Meters
M6	5.6	1.0	3.6-5.8	4.9-7.9	-	-	-
	8.8		5.8-9.4	7.9-12.7		-	-
	10.9		7.2-10	9.8-13.6		-	-
M8	5.6	1.25	7.2-14	9.8-19	1.0	12-17	16.3-23
	8.8		17-22	23-29.8		19-27	25.7-36.6
	10.9		20-26	27.1-35.2		22-31	29.8-42
M10	5.6	1.5	20-25	27.1-33.9	1.25	20-29	27.1-39.3
	8.8		34-40	46.1-54.2		35-47	47.4-63.7
	10.9		38-46	51.5-62.3		40-52	54.2-70.5
M12	5.6	1.75	28-34	37.9-46.1	1.25	31-41	42-55.6
	8.8		51-59	69.1-79.9		55-68	75.9-92.1
	10.9		57-66	77.2-89.4		62-75	84-101.6
M14	5.6	2.0	49-56	66.4-75.9	1.5	52-64	70.5-86.7
	8.8		81-93	109.8-126		90-106	122-143.6
	10.9		96-109	130.1-147.7		107-124	145-168
M16	5.6	2.0	67-77	90.8-104.3	1.5	69-83	93.6-112.5
	8.8		116-130	157.2-176.2		120-138	162.6-187
	10.9		129-145	174.8-196.5		140-158	189.7-214.1
M18	5.6	2.0	88-100	119.2-136	1.5	100-117	136-158.5
	8.8		150-168	203.3-227.6		177-199	239.8-269.6
	10.9		175-194	237.1-262.9		202-231	273.7-313
M20	5.6	2.5	108-130	146.3-176.2	1.5	132-150	178.9-203.3
	8.8		186-205	252-277.8		206-242	279.1-327.9
	10.9		213-249	288.6-337.4		246-289	333.3-391.6