

UTV UNIVERSAL Plow Kit
6' Wide Snow Plow (Self-Contained Hyd.)
 (p/n: 1UTVP = factory assembled)
 (p/n: 1UTVP-1 = assembly required)

For the 1UTVP version, the instructions are on pages 3-6. Approximate installation time: 1/2 an hour.
 For the 1UTVP-1 version, the assembly instructions are on pages 11-19. Approximate installation time: 3 hours.
 Page 2 safety and maintenance info. pertain to both p/n's (both plows kits).

These instructions are only valid for the Plow portion. Please see separate instructions for the required Mount Kit.

Note: Front Heavy Duty Springs or Heavy Duty Spring Damper Assembly are required if plow is installed.

Total weight = 254 lbs. for either plow kit (frame mount kits add an additional 30 lbs. max. for a grand total of 284 lbs. max.)

NOTE: Jack Legs and Blade Markers are discussed here, but are separately purchased items.

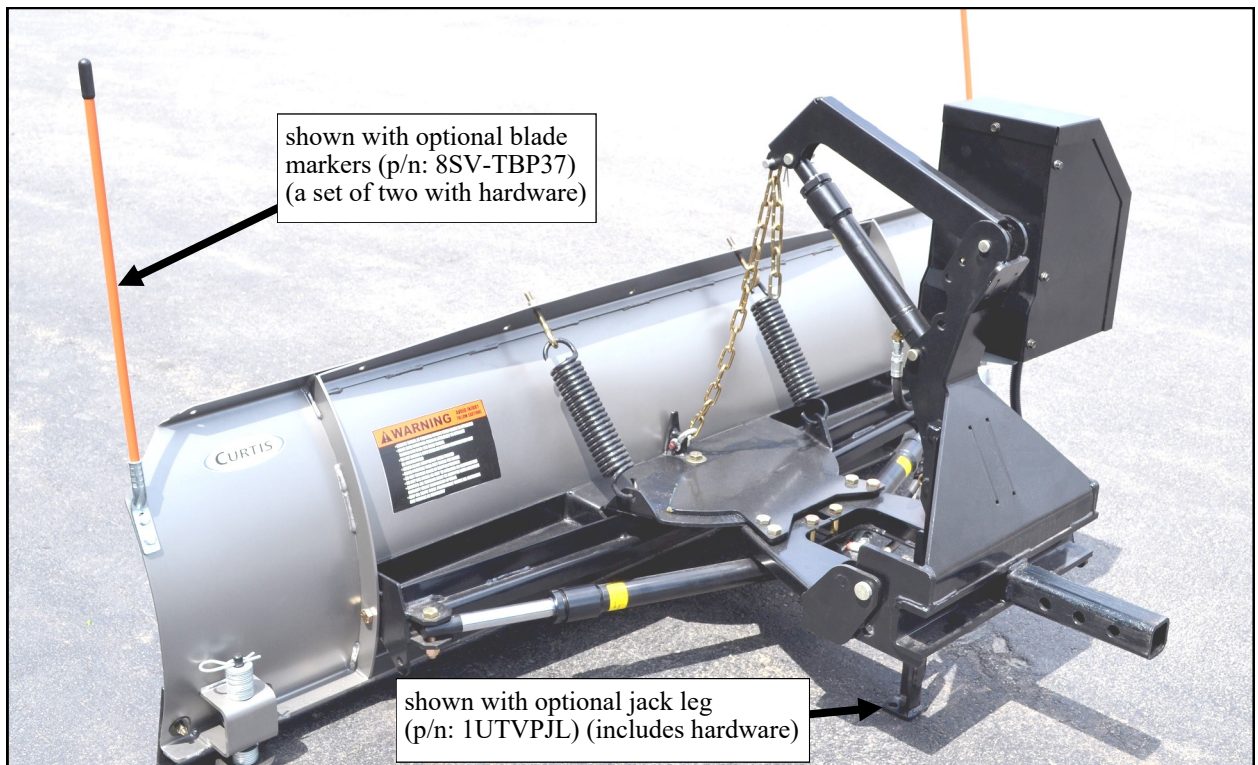

WARNING
 Do not attempt to install or operate this plow until you read and understand all warnings and instructions in this manual or on the plow. Failure to read all warnings and instructions could lead to serious injury or death.

ADDED WEIGHT NOTICE
 Curtis Cabs, blades and general accessories add additional weight to the base vehicle. All Curtis accessory weights are listed in product brochures. Deduct the accessory's total weight from the vehicle's rated capacity and never exceed the vehicle's rated capacity including driver and passenger.

SAFETY INFORMATION:

⚠ WARNING: Cabs, blades, and general accessories add additional weight to the base vehicle. Deduct the accessory's total weight from the vehicle's rated capacity including driver and passenger. Never operate the vehicle outside of its rated weight capacity.

⚠ WARNING: Exposure to Carbon Monoxide can cause illness, serious injury or death. Never operate vehicle if suspicious of Carbon Monoxide. Inspect exhaust system for leaks monthly. Leaks can result from loose connections, corrosion, cracks or other damage to the exhaust manifold. If leaks are found, repair or replace exhaust system. Do not use vehicle until repair or replacement is complete.

WARNING: Serious injury or death:

- Never stand or ride on the plow assembly.
- ⚠** • Never operate the plow near pets or other people.
- Never leave the vehicle running unattended with plow attached.
- Never plow or carry plow at high speeds.
- Never clean or perform maintenance with plow raised.
- Never clean or service with plow in tripped condition.
- Never dislodge an obstruction with any part of the body.
- Warning - This attachment affects the handling performance.
- Warning - Before starting installation, park RTV in a flat area, ensure parking brake is engaged, and engine is turned off.

HELPFUL REMINDERS:

- A. Check carton contents prior to beginning installation.
- B. Work in an organized area large enough to fit vehicle and plow.
- C. Have the required tools ready to speed up the installation time.
- D. Have a helper available to help move heavy parts and assemblies.

The Installation should be done by “qualified personnel”.

MAINTENANCE NOTES:

- **Check and tighten all fasteners in the plow assembly and vehicle mounting after initial use and every 5 hours of use thereafter.**
- **After every 10 hours of use, lubricate all pivot bolts, pins, snap lock latches, and any other moving parts in the plow assembly with all-season grease.**

Supplies required for 1UTVP (factory assembled plow):

Dielectric Grease
AW 32 Plow Oil

TOOLS REQUIRED:

1. Install UTV Plow Into Receiver out of shipping crate

- 1.1 Remove plow from shipping crate. Loosen chain, straighten up the lift frame, and if applicable, install the Jack Leg (if purchased as a separate option) in lower position locking the Lift Frame and A-Frame together per section 3 on page 5.
- 1.1 Apply grease to the stem of the lift frame and the inside of the receiver. Move the lift frame to the receiver of your vehicle so that the stem on the lift frame is lined up with the female end tube of the receiver hitch. See Figure 1.1.
- 1.2 Push the lift frame into the receiver hitch until the holes align making sure the lift frame clears the bumper and grill of your vehicle.
- 1.3 Install pin thru hole on receiver and lift frame stem and secure. See Fig 1.2

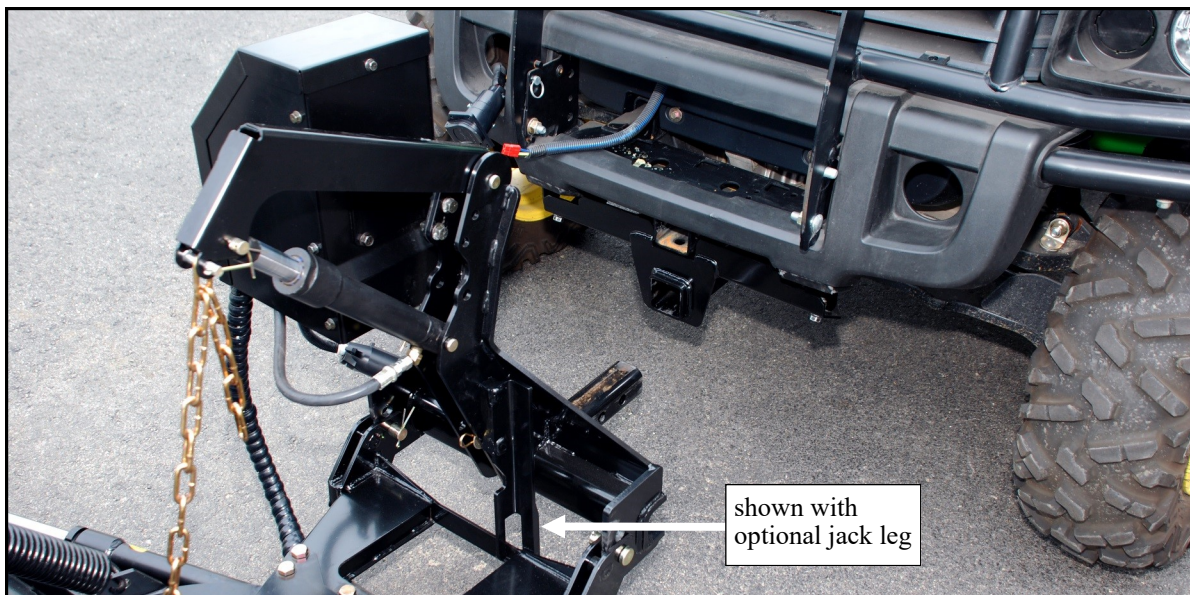

Fig. 1.1—Lift Frame and Receiver Setup



Fig. 1.2—Lift Frame and Receiver Pin
(Under Vehicle)

2. Alternate Install UTV Plow Into Receiver using shipping crate

- 2.1 Remove top and sides from shipping crate. Cut crate as shown to allow front wheels of UTV to enter crate base. Move UTV to align with stem on Lift Frame of plow. See Figure 2.1. Front wheels of UTV may encroach into the cutout made on the crate base. Slide pallet jack under crate and lift so that stem on Lift Frame and Receiver are in line. Apply grease on stem of Lift Frame.
- 2.2 Unhook chain from Lift arm and readjust so that there is plenty of slack in chain approximately 4-5 free links after clevis pin. Unbolt shipping straps in front and cut green shipping strap on Lift Frame stem. Hold onto lift frame making sure to keep it from dropping forward. Then move vehicle so that stem on Lift frame slides into Mount receiver and slide all the way into mount making sure the lift frame clears the bumper and grill of your vehicle. Install pin thru hole on receiver and lift frame stem and secure.
- 2.2 Plug in 7 Pin connector from Pump Assembly to mating Plug on Vehicle. Activate plow and lift off pallet base, move pallet base away and lower plow to ground.

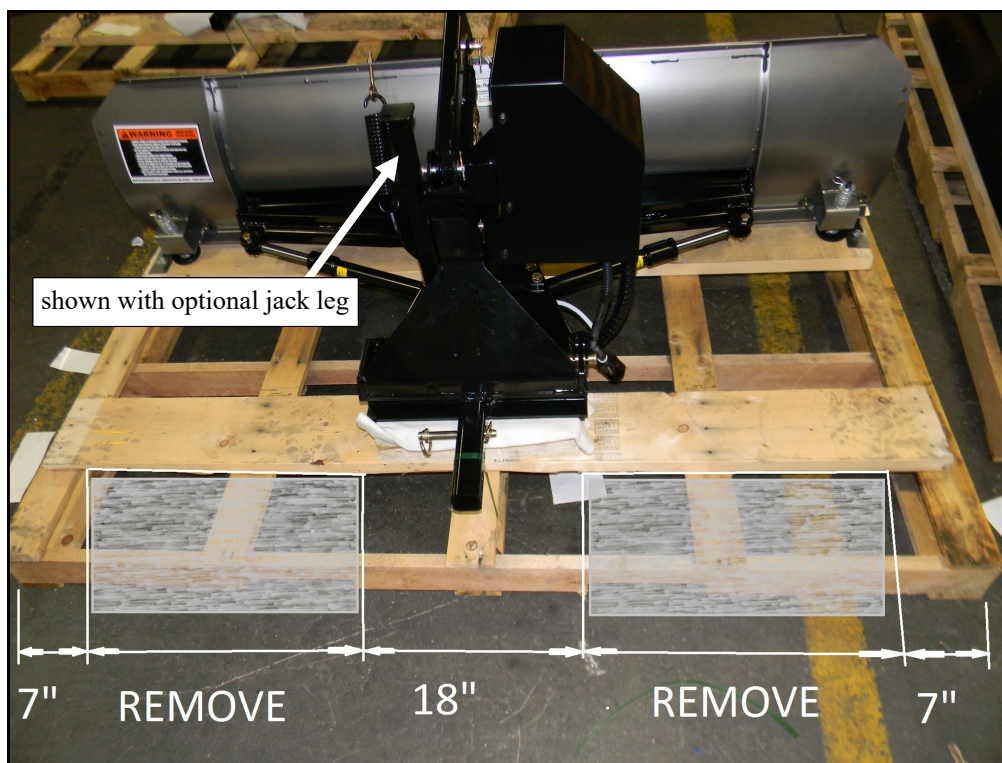

Fig. 2.1—Lift Frame and Receiver Setup



Fig. 2.2—Lift Frame and Receiver Setup



Fig. 2.3—Lift Frame and Receiver Pin
(Under Vehicle)

3. Jack Leg Operation (skip this section if this optional item was not purchased)

- 3.1 Before removing plow from vehicle, remove the two cotter pins and flat washers from the jack leg and flip the leg over so that the foot pad is down.
- 3.2 Make sure that the hook on the leg captures the back strap of the A-Frame. Re-install leg through the original holes and attach with washers and pins. Per figure 11.2

⚠ Warning:
Never operate plow with rear jack leg in lower position. Damage will occur.

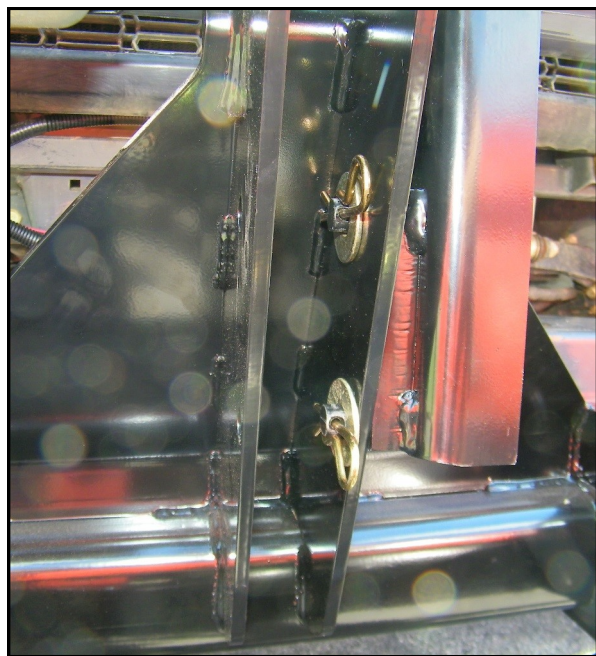

Fig. 11.1B— Jack Leg Pins



Fig. 11.2—Jack Leg in use

4. Adjusting A-Frame to Lift Frame

- 4.1 Apply grease to the pivot holes in the rear of the A-Frame and the lower Lift Frame.
- 4.2 Align the Tabs of the A-Frame with tabs on the Lift Frame. Three pivot holes are provided on lift frame to accommodate varying vehicle heights.
- 4.3 Make sure A-Frame is level with the ground and insert $\frac{3}{4}$ " x 2" long clevis pin into the appropriate hole. Double check for levelness and install cotter pins.
- 4.4 Adjust Lift Arm and Lift Cylinder so that 2" of chrome on the lift cylinder is showing. Attach lift chain to Lift Arm with clevis pin so that a slight amount of slack is left in the chain.

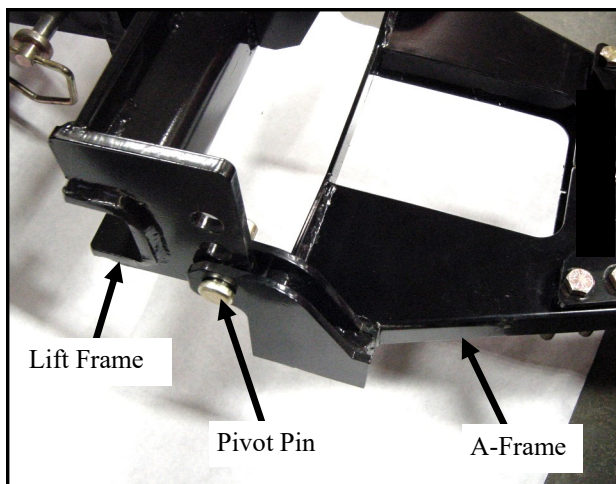

Fig. 4.1 A-Frame and Lift Frame Mounting Tabs

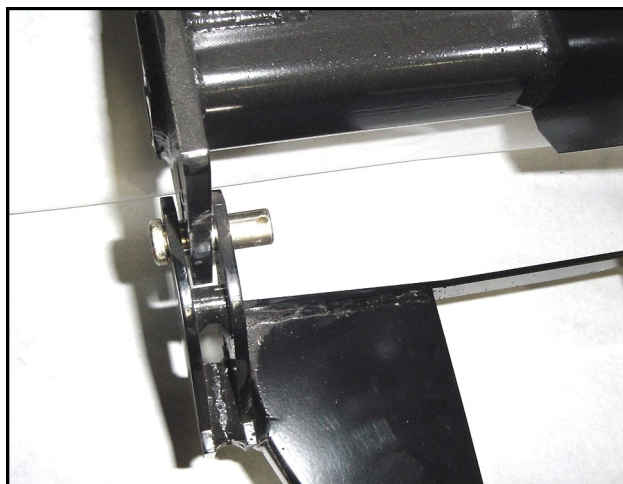
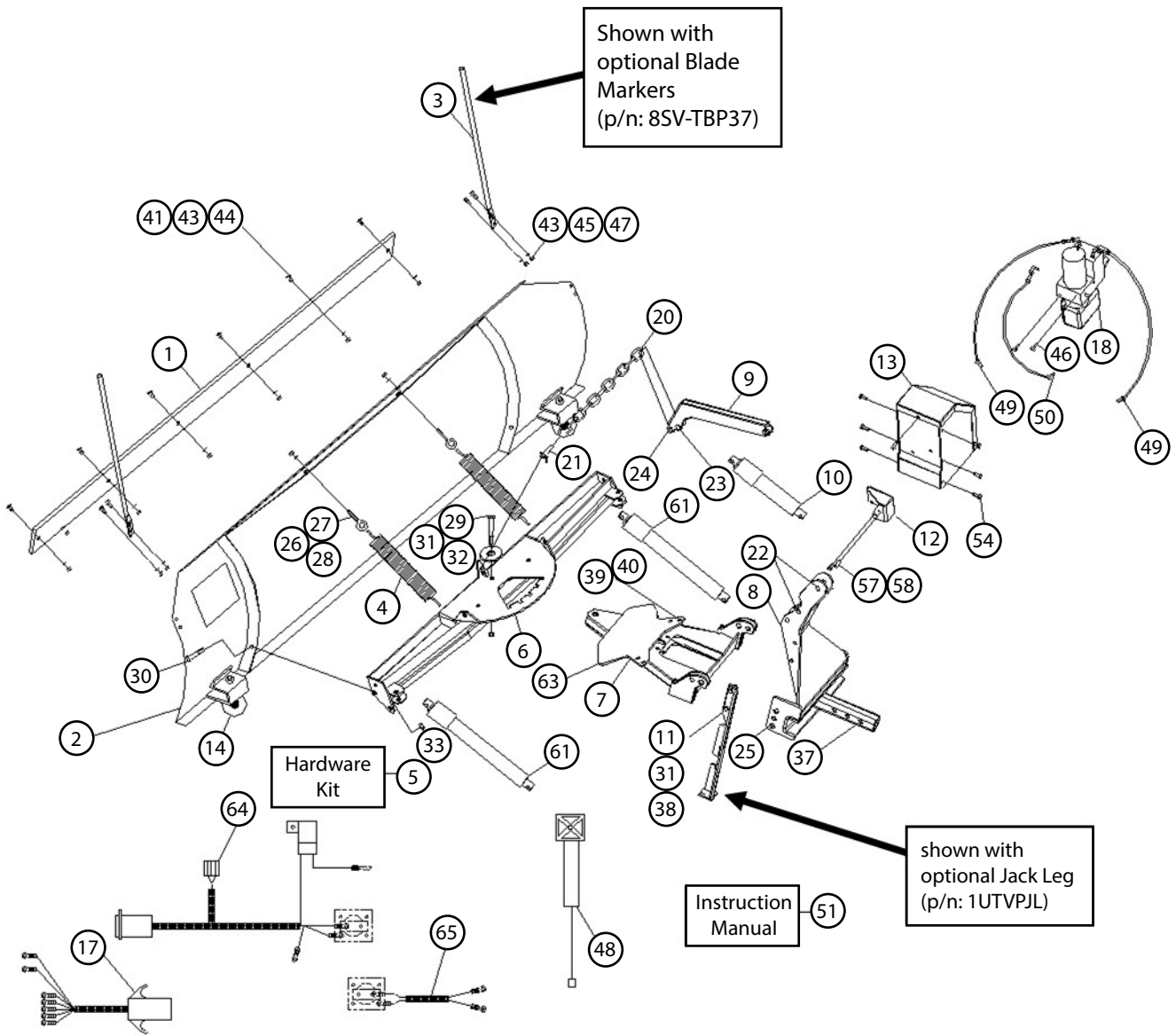

Fig. 4.2 A-Frame and Lift Frame Mounting Tabs



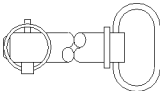





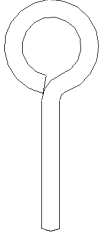

















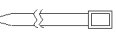

Fig. 4.3 Level A-Frame

UTV Universal Plow Kit (p/n's: 1UTVP and 1UTVP-1) 6' Wide Snow Plow (Self contained Hyd.)



UTV Universal Plow Kit (p/n's: 1UTVP and 1UTVP-1) 6' Wide Snow Plow (Self contained Hyd.)

Hardware List

	1X - 3/8" x 2" Clevis Pin		1X - 5/8 x 5 3/4 LG Hitch Pin W/Lynch Pin
	1X - 1/2" x 2" Clevis Pin		4X - 1/2 -13 x 1 1/2" Hex Head Bolt
	2X - 1/2" x 2 1/2" Clevis Pin		4X - 1/2" Lock Washer
	2X - 3/4" x 2" Clevis Pin		2X - 1/8" Cotter Pin <small>supplied w/ Hair Pin X 2.56 LG</small> optional jack leg
	2X - 3/8" x 2 1/2" Eye Bolt		8X - 5/16 -18 x 1 1/4" Carriage Head Bolt
	2X - 3/8" Flat Washer		4X - 5/16" Flat Washer
	2X - 3/8" -16 Nylon Insert Locknut		12X - 5/16" Nylon Insert Locknut
	1X - 1/2" -20 x 3 1/2" Hex Head Bolt		8X - 5/16" Flat Washer Fender
	4X - 1/2 -13 x 2 1/2" Hex Head Bolt		4X - 5/16"-18 x 1" Hex Head Bolt
	3X - 1/2" Flat Washer		7X - 1/4-20 x 3/4 Hex Flange Head Bolt
	6X - 1/2-13 Nylon Insert Locknut		1X - 1/4-20 x 1" Hex Head Bolt
	1X - 1/2-20 Grade "C" Locknut		1X - 1/4-20 Nylon Insert Locknut
			2X - 5/16-18 x 3/4" Hex Head Bolt
			2X - 3/8-16 x 1" Hex Head Bolt
			2X - 3/8"-16 Nylon Insert Flanged Locknut
			8X - 1/4 x 12" LG Nylon Wire Tie
			2X - 1/2 -13 x 4 1/2" Hex Head Bolt

UTV Universal Plow Kit (p/n's: 1UTVP and 1UTVP-1)

Part	Description	Part Number	Qty.
1	Cutting Edge	UTVP-CE	1
2	Steel Moldboard Assembly	KAF25-039P7MG	1
3	OPTIONAL Blade Marker Kit (sold as pair) w/hardware	8SV-TBP37	1
4	Trip Spring (sold separately)	KAF25-039SP	1
5	Hardware Kit	KX9HWK-UTP	1
6	Trip Frame	KAF25-039P8	1
7	A-Frame Assembly Complete	1TBP29LD-1	1
8	Lift Frame	1TBP38LD	1
9	Lift Arm	1TBP40LD	1
10	1" Dia. x 6" Stroke S.A. Hydraulic Cylinder	1TBP104	1
11	OPTIONAL Jack Leg with Hardware	1UTVPJL	1
12	Pump Mounting Bracket	1TBP-LDMB	1
13	Pump Mounting Cover (2 pieces)	8SV-TBPLDPMC-B5	1
14	Skid Shoe Assembly (sold as pair) w/ washers and pins	UTV-SHOE	1
15	Wiring Harness - Main Wire Harness	KX9UTP-WHHLA02	1
16	Wiring Harness - Battery Wire Harness	KX9UTP-WHHLA03	1
17	Wiring Harness - Front Coil & Motor Harness	KX9UTP-WHHLA01	1
18	Hydraulic Pump Ass'y. w/Valves and Motor	1TBP59LD	1
19	MJ x MB Adapter 90 Deg.	1TBP98LD-1	1
20	26" long 4/0 Chain	V4208-18	1
21	5/16" 3/4 Ton Anchor Shackle	V4208-19	1
22	1/2" x 2 1/2" Clevis Pin w/Cotter Pin	1VP14	2
23	1/2" x 2" Clevis Pin w/Cotter Pin	1CP109	1
24	3/8" x 2" Clevis Pin w/Cotter Pin	1CP110	1
25	3/4" x 2" Clevis Pin w/Cotter Pin	1CP111	2
26	3/8" x 2 1/2" Eye Bolt	79-01-0001	2
27	3/8" Flat Washer	71-00-0037	2
28	3/8-16 Nylon Insert Locknut	72-01-0027	2
29	1/2-20 x 3 1/2" long Hex Head Bolt Gr. 8	70-00-0110	1
30	1/2-13 x 2 1/2" long Hex Head Bolt Gr. 5	70-00-0111	4
31	1/2" Flat Washer USS (2 supplied w/ OPTIONAL Jack Leg)	71-00-0038	3
32	1/2-20 Grade "C" Locknut	72-02-0026	1
33	1/2-13 Nylon Locknut	72-21-0001	6
37	5/8 x 5-3/4 long Hitch Pin w/Lynch Pin	1SM1P2	1
38	1/8" Cotter Pin Hair Pin x 2.56 long (supplied w/ OPTIONAL Jack Leg)	79-12-0010	2
39	1/2-13 x 1-1/2" long Hex Head Bolt Gr. 8	70-00-0112	4
40	1/2" Lock Washer	71-15-0036	4
41	5/16-18 x 1-1/4" long Carriage Head Bolt	70-69-0002	8
42	5/16" Flat Washer USS	71-01-0003	4
43	5/16 -18 Nylon Locknut	72-01-0002	12
44	5/16" Flat Washer Fender	71-02-0007	8
45	5/16-18 x 1" long Hex Head Bolt	70-00-0007	4
46	5/16-18 x 3/4" long Hex Head Bolt (Grade 8)	70-05-0064	2
47	5/16" Flat Washer	71-00-0035	4

UTV Universal Plow Kit
(p/n's: 1UTVP and 1UTVP-1)
6' Wide Snow Plow (Self-Contained Hyd.)

48	Hand Held Plow Controller	1HHC	1
49	40" long Hose	HYDR04	2
50	18" long Hose	HYDR05	1
51	Installation Instructions	IM-1UTVP	1
52	90° Elbow with Patch Sealant for Angle Cylinder	1TBP98G	2
53	45° Elbow for Lift Cylinder	1TBP98H	1
54	1/4-20 x 3/4" long Hex Head Bolt (Grade 5) (plated)	70-00-0021	7
55	1/4-20 Hex Flange Nut Nyloc	72-21-0008	1
57	3/8-16 x 1" long Flanged Hex Head Bolt	70-05-0064	2
58	3/8-16 Hex Flange Nut Nyloc	72-21-0086	2
59	Harness Spiral Wrap Cut 20" long	1TBP129-20	1
60	1/2-13 x 4-1/2" long Hex Head Bolt (Grade 5) (plated)	V4207P18	2
61	1" Dia. x 12" Stroke S.A. Hydraulic Cylinder	V4207P1	2
62	1/4" x 12" long Black Nylon Wire/Hose Tie	V4207P15	8
63	A-Frame Pinch Guard	1TBP29PG	1
64	Wire Harness, Main, Hyd. UTV Plow	KX9UTP-WHHLA02	1
65	Wire Harness, Battery, Hyd. UTV Plow	KX9UTP-WHHLA03	1
	DC Motor 12-Volt	1TBM300	1
	Angle/Lift Valve with Coil Kit	1TBM303	1
	Float Valve with Coil	1TBM305	1
	Pump Assembly Kit	1TBM307	1
	Hydraulic Pump Filter Kit	1TBM308	1
	Hydraulic Power Unit Reservoir Kit	1TBM309	1
	Fixed Relief Valve	1TBM310	1
	Return Tube Kit	1TBM311	1
	Reservoir Cap	1TBM312	1
	12-Volt Motor Solenoid	1TBP61A	1
	Wire Harness Bracket Kit, Utility Vehicle Plow	KX9UTP-WHBK	1

Pages 11-19 are for unassembled plow kit p/n: 1UTVP-1 only.

TOOLS REQUIRED:

Set of standard and metric sockets
 Set of standard and metric open end wrenches
 One 3/8" Drive Ratchet
 Pliers
 Dielectric Grease
 AW 32 Plow Oil

1. Trip-frame to Moldboard Assembly

- 1.1. Per fig 1.1, locate the steel moldboard, trip frame, two 1/2-13 x 2 1/2" bolts, and two 1/2-13 Nylock locking nuts. Apply all-season grease to the mating surfaces on the trip frame and moldboard rib. As shown, line up the mounting hole in the trip frame with the mounting hole on the moldboard rib (near the bottom). Install into the mounting holes a 1/2-13 x 2" bolt as shown. Install a 1/2-13 Nylock nut on the back side of the bolt. Repeat installation of hardware for the right side, orienting the bolt head to face away from the center of the moldboard. Tighten the Nylock nuts until all thread slack is removed from the assembly while allowing the trip-frame to rotate freely.

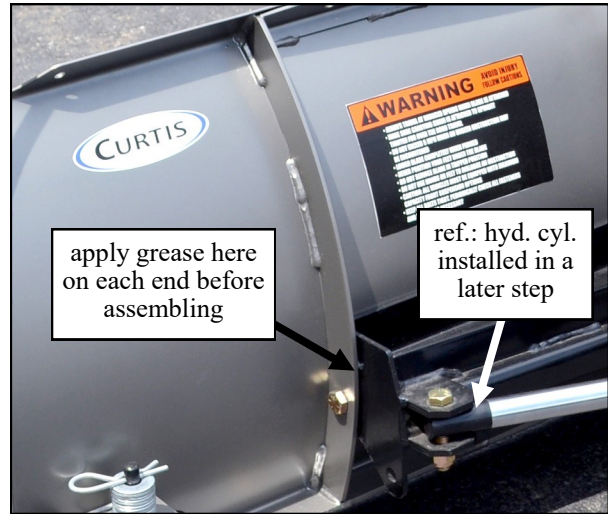

Fig. 1.1—Trip Frame to Moldboard

2. Trip Spring Installation

- 2.1 Per fig 2.1, locate the two trip springs, two eye bolts, two 3/8-16 Nylock hex nuts, and two 3/8" washers.
- 2.2 *Note: Trip frame is shown an exaggerated distance away from moldboard to clarify trip spring placement.* Per Fig 2.2, hook one end of the trip spring through the lower trip spring mount. Hook the eyebolt on the other end of the spring and insert the threaded section up through the hole in the upper spring mount. Install a 3/8" washer, then a 3/8" Nylock hex nut on the eyebolt. Repeat above for the second trip spring.
- 2.3 Set the spring tension by tightening the Nylock nut until a sheet of paper can slide between two coils on the spring. Be sure to set tension evenly in both springs.



Fig 2.1—Trip Springs and Hardware



Fig. 2.2—Trip Spring Installation

3. A-Frame Installation

- 3.1 Per fig 3.1, locate the A-frame, one 1/2-20 x 3.5" hex head bolt, one 1/2-20 conical locking hex nut, and one 1/2" washer. Apply all-season grease to the top and bottom surface of the A-frame around and in the 1/2" bolt hole. Grease should extend about an inch away from the center of the hole.
- 3.2 Per fig. 3.2, slide the A-Frame into the trip frame pocket, aligning the 1/2" bolt holes on both assemblies. Install the 1/2-20 x 3.5" hex head bolt with a 1/2" washer under the head of the bolt. Then thread on the lock nut. Tighten until all slack is removed from the bolt while the A-frame is allowed to rotate freely in the trip frame pocket.
- 3.3 Apply grease to the under side of the Pinch Guard in the area where it will contact the trip frame. Position the Pinch Guard bracket with the spacers down and with the four holes lined up with the corresponding holes in the top of the A-Frame. Fasten the bracket using four 1/2-13 x 1 1/2" hex head bolts and 1/2" lock washers. Make sure the A-Frame pivots in both directions.

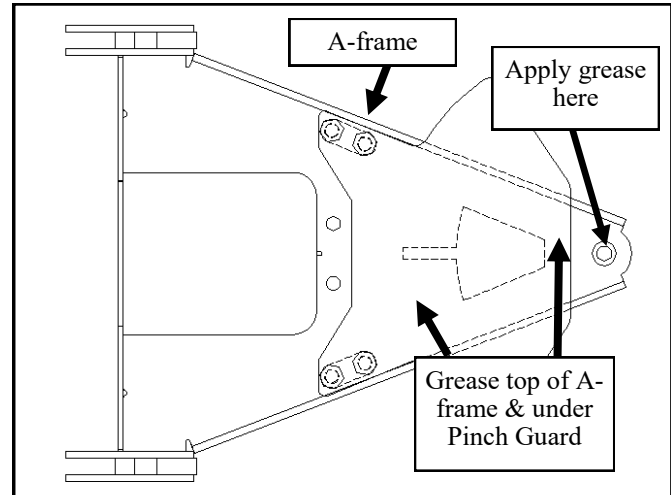

Fig. 3.1—A-Frame and Hardware

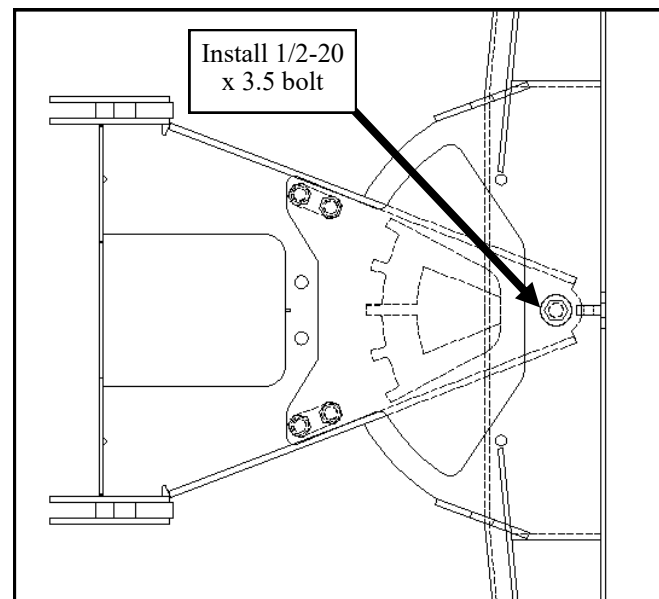

Fig. 3.2—A-Frame and Trip Frame

4. Chain Shackle Installation

- 4.1 Locate the Lift Chain Shackle per fig 4.1
- 4.2 Per fig 4.2, slide Lift Chain through shackle then insert the clevis pin on the lift chain shackle into the lifting hole on the trip frame. Slip Cotter pin into hole on clevis pin and bend back to lock in place.

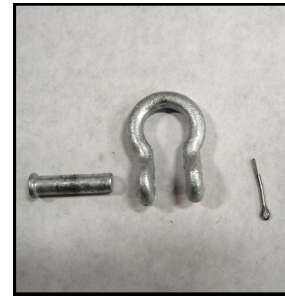

Fig. 4.1—Lift Chain Shackle

5. Attach Lift Arm to Lift Frame

- 5.1 See fig. 5.1. Apply thread sealer on 45° Elbow and thread into port on lift cylinder. Making sure it points towards the piston end of the cylinder.
- 5.2 Apply grease to the pivot holes of the Lift Arm, Lift Cylinder, and the Upper Lift Frame. Place the fixed end of the Lift Cylinder between the vertical plates of the Lift Frame. Make sure that the hydraulic inlet is pointing away from the machine, line up lower hole in lift frame with rod hole in Lift Cylinder.
- 5.3 Place 1/2" x 2 1/2" clevis pin in place to hold. Place the back end of the Lift Arm between the vertical plates of the Lift Frame.
- 5.4 Line up upper hole in lift frame with rear hole in lift arm. Place 1/2" x 2 1/2" clevis pin in place to hold.
- 5.5 Place the piston end of the Lift Cylinder between the plates of the Lift Arm as shown, line up holes and place 1/2" x 2" clevis pin in place to hold. Then insert cotter pins in all (3) clevis pins to lock in place per Fig 5.1

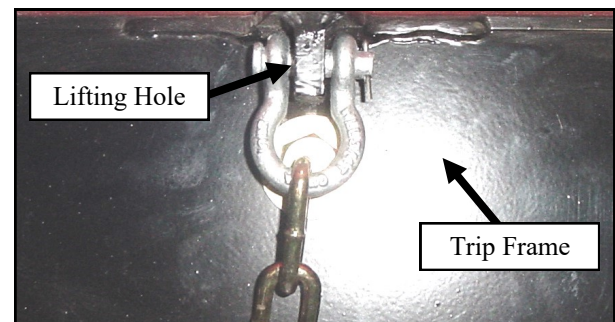

Fig. 4.2—Shackle installed on Trip Frame

6. Install Lift Frame into Mount Kit Receiver

- 6.1 Apply grease to the stem of the lift frame and the inside of the receiver. Move the lift frame to the receiver of your vehicle so that the stem on the lift frame is lined up with the female end tube of the receiver hitch.
- 6.2 Push the lift frame into the receiver hitch until the holes align making sure the lift frame clears the bumper and grill of your vehicle.
- 6.3 Install pin thru hole on receiver and lift frame stem and secure. See fig. 6.3.



Fig. 6.3 Pin on Receiver

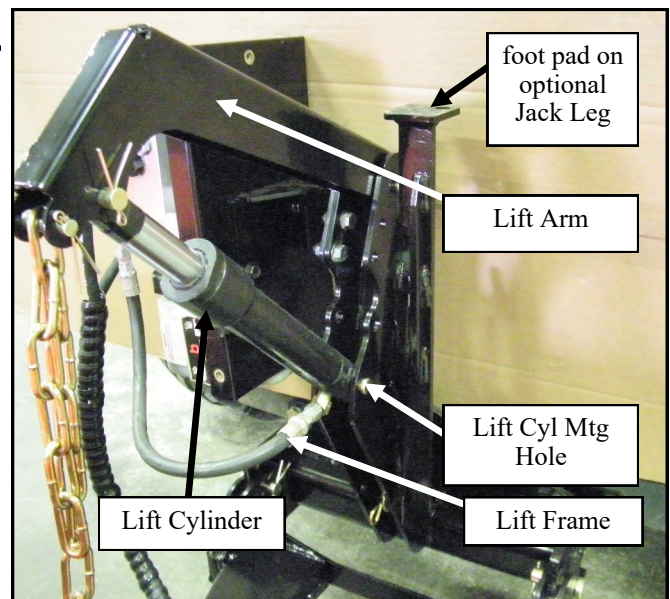

Fig. 5.1 Lift Frame and Lift Arm

7. Attach A-Frame to Lift Frame

- 7.1 Apply grease to the pivot holes in the rear of the A-Frame and the lower Lift Frame. See fig. 7.1.
- 7.2 Align the Tabs of the A-Frame with tabs on the Lift Frame. Three pivot holes are provided on lift frame to accommodate varying vehicle heights.
- 7.3 Make sure A-Frame is level with the ground and insert $\frac{3}{4}$ " x 2" long clevis pin into the appropriate hole. Double check for level and install cotter pins. See fig. 7.3.
- 7.4 Adjust Lift Arm and Chain so that 2" of chrome on the lift cylinder is showing. Attach lift chain to Lift Arm with clevis pin so that a slight amount of slack is left in the chain. See fig. 7.4.

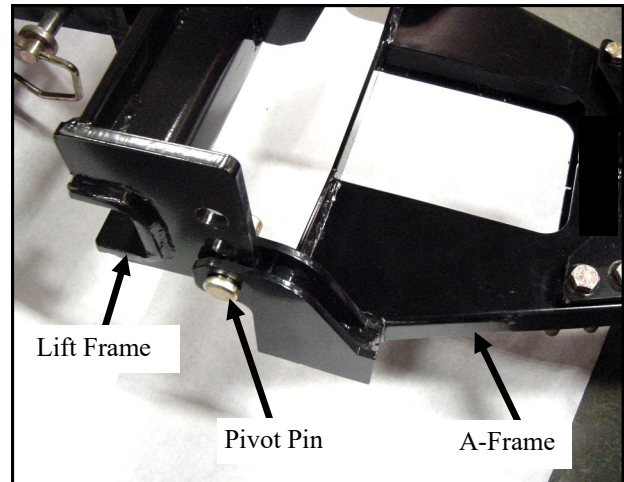

Fig. 7.1 A-Frame and Lift Frame Mounting Tabs

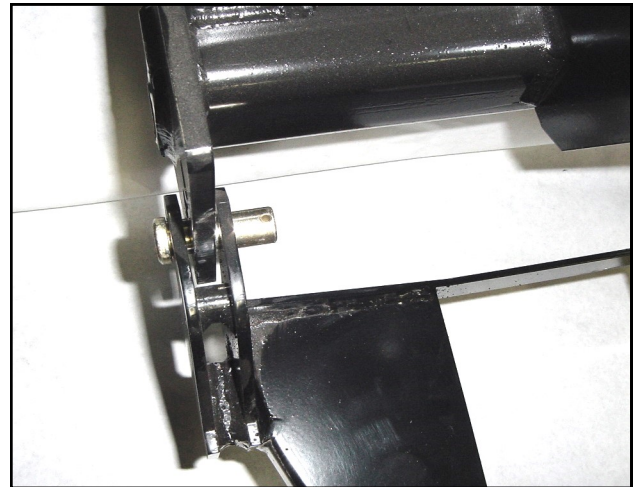

Fig. 7.3 A-Frame and Lift Frame Mounting Tabs



Fig. 7.4 Attach Chain

8. Pump to Lift Frame

- 8.1. Per figures 8.1, 8.2, and 8.3, position Pump Assembly, Side Cover, and Mounting Bracket up against the top of the lift frame matching up mating holes on lift frame and mounting bracket. Using the two 3/8-16 x 1" bolts, and two 3/8-16 Nylock nuts, attach bracket to lift frame. Tighten the Nylock nuts until all thread slack is removed from the assembly.
- 8.2 Both wiring harnesses are shown in the electrical diagram at the bottom of the page. At location A, use a #10 x 3/4" long self-drilling screw. At location B, use two #10 x 3/4" long self-drilling screws and two 1/4" washers. See the next two pages for additional electrical information. Plug the 7 pin connector from the hydraulic pump and motor assembly into the vehicle end of the 7 pin connector.

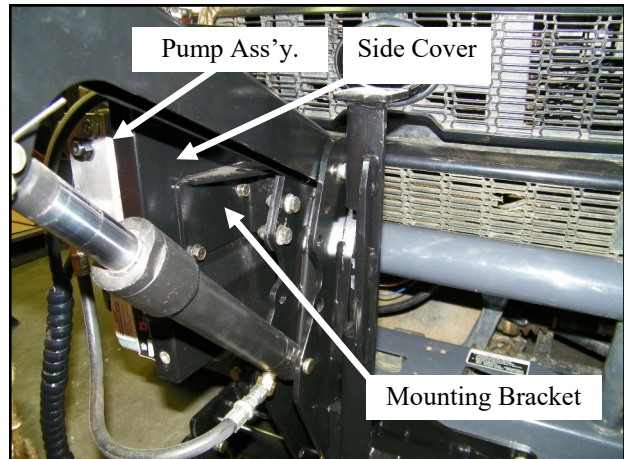

Fig. 8.1—Pump and cover installation

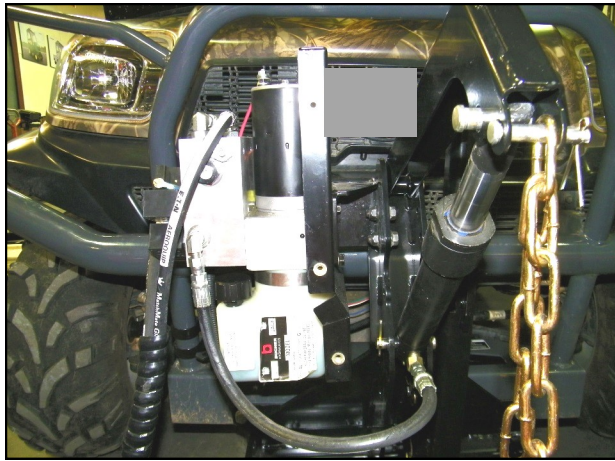

Fig. 8.2—Pump and cover installation

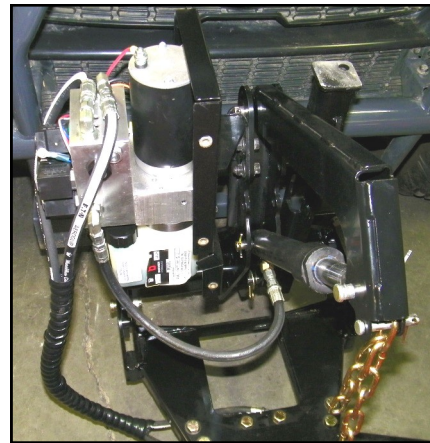
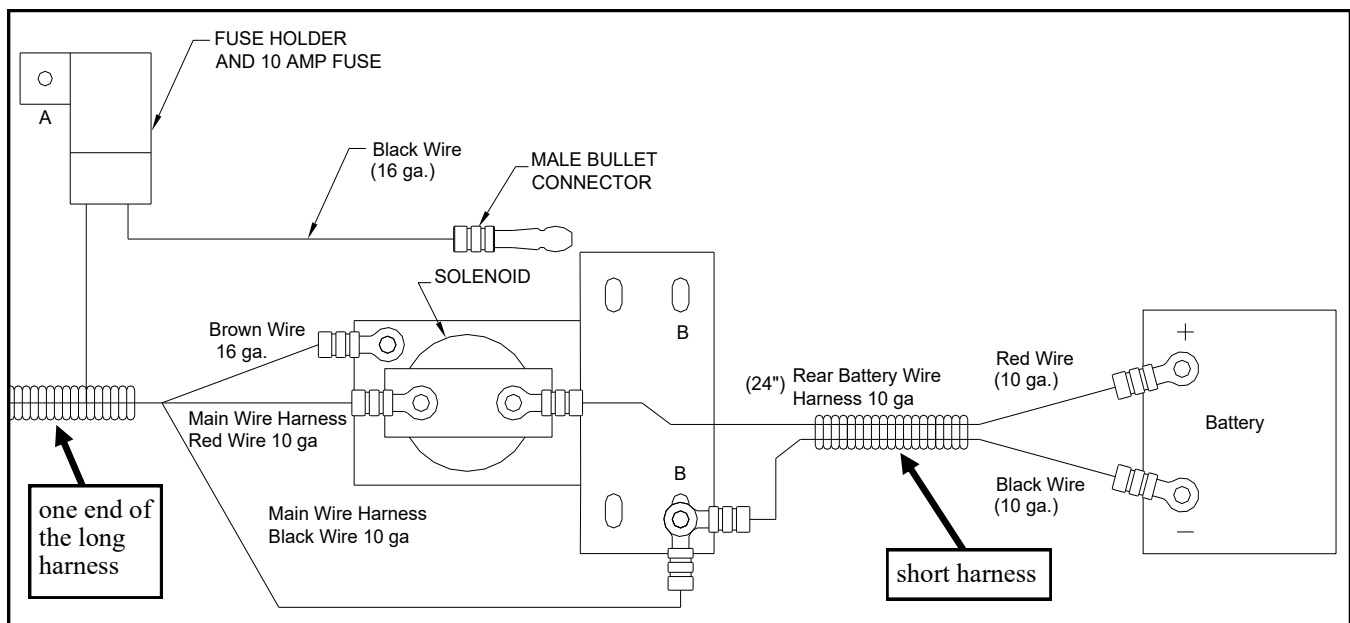
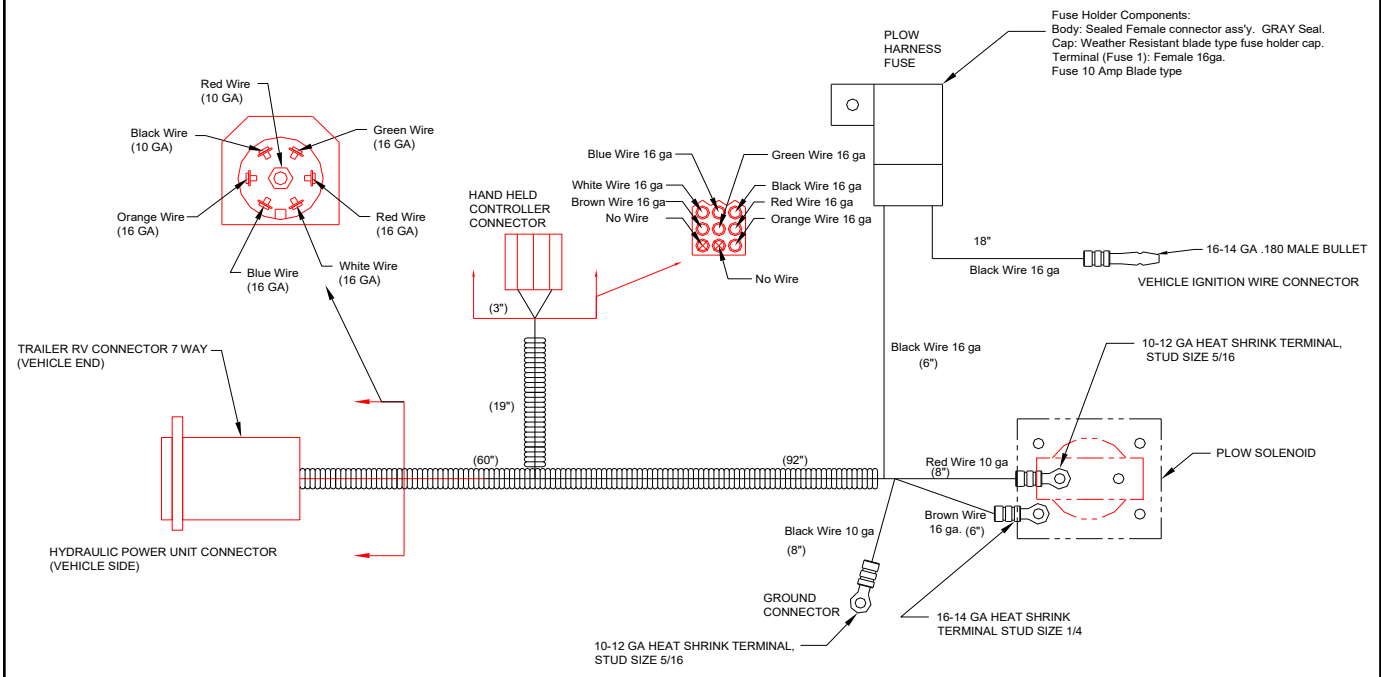

Fig. 8.3—Pump and cover installation



MAIN WIRE HARNESS



The long harness

FRONT COIL & MOTOR HARNESS

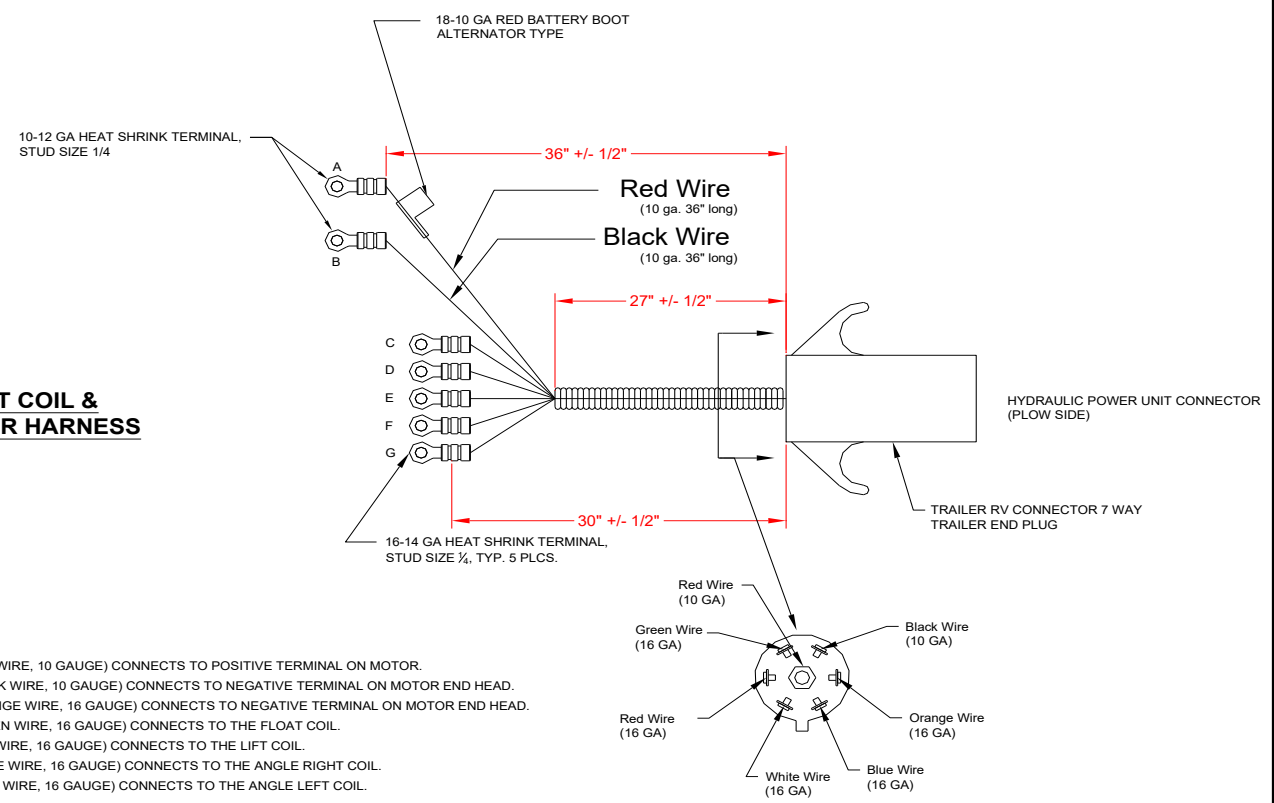

The short harness

Photo shows specific coil studs for 16 gauge wire connections.

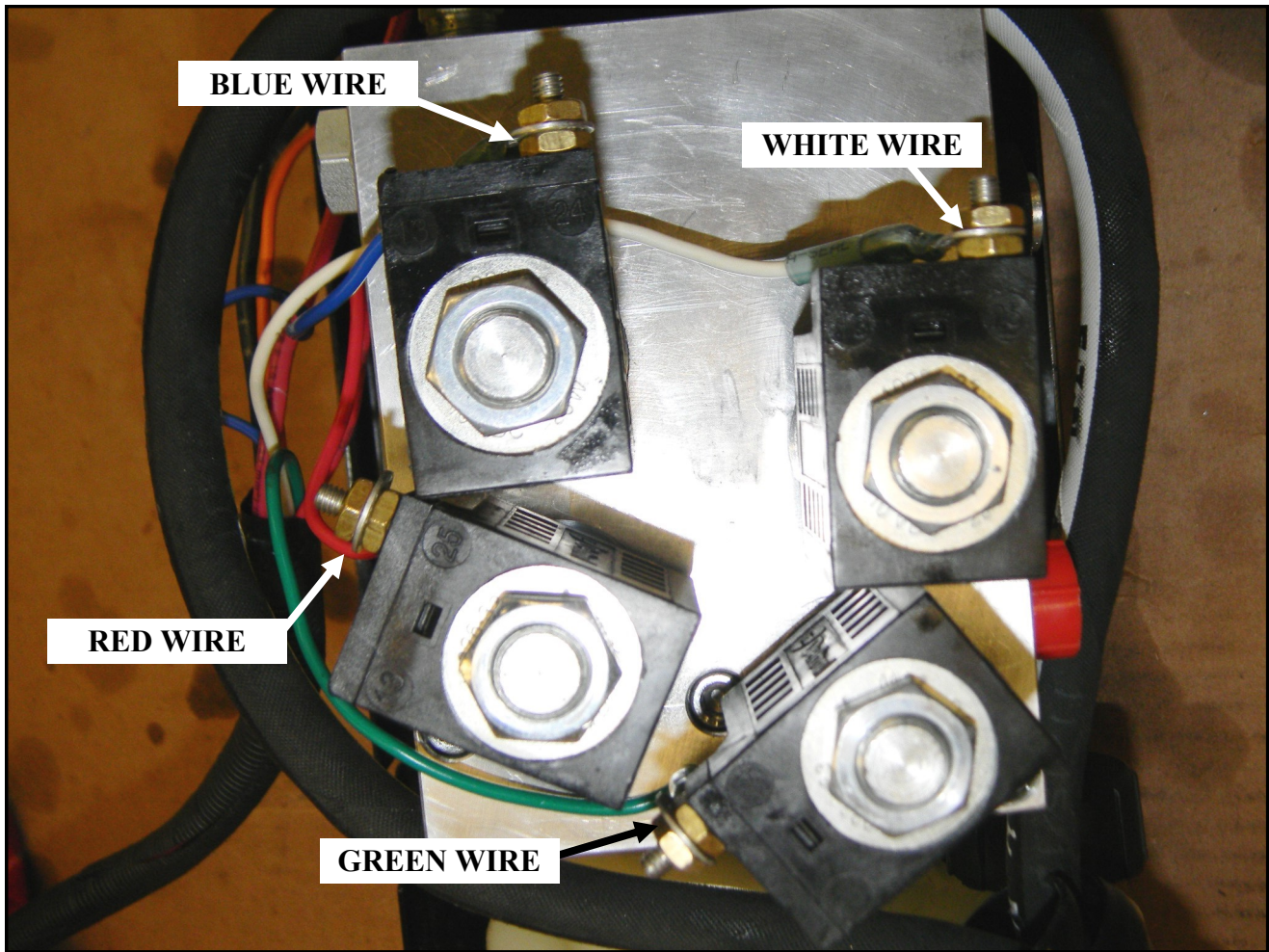

9. HYDRAULIC ANGLE CYLINDERS AND LIFT CYLINDER:

- 9.1 Apply thread sealer on 90° Elbow and thread into port on angle cylinder. Making sure one points towards the piston end of the cylinder and one points towards the fixed end of the cylinder.
- 9.2 Place the fixed end of each angle cylinder into its respective bracket under the plow A-frame making sure that 90° Elbow is in orientation shown. Insert 1/2-13 x 4 1/2" bolts through the plow A-frame, the stationary ends of the angle cylinders, and the lower cylinder brackets of the A-frame. Fasten and tighten using 1/2-13 lock nuts. See Fig. 9.2. (Do not over tighten, 1 to 3 threads should be showing past nut)
- 9.3 Attach the piston end of the angle cylinders between the brackets at the outer ends of the back side of the plow trip frame using 1/2-13 x 2 1/2" bolts. Fasten and tighten using 1/2-13 lock nuts. See Fig. 9.3. (Do not over tighten, 1 to 3 threads should be showing past nut)
- 9.4 Attach and tighten the free end of each of the 40" long hydraulic hoses to the swivel elbow in its respective angle cylinder. The hydraulic hose with the blue mark coming out of port C1 on pump manifold will be attached to the left side cylinder (driver's side). See Fig. 9.4.
- 9.5 Attach and tighten the swivel end of the 12" long hydraulic hose to the elbow on the fixed end of the lift cylinder that was installed previously. See Fig 9.5.

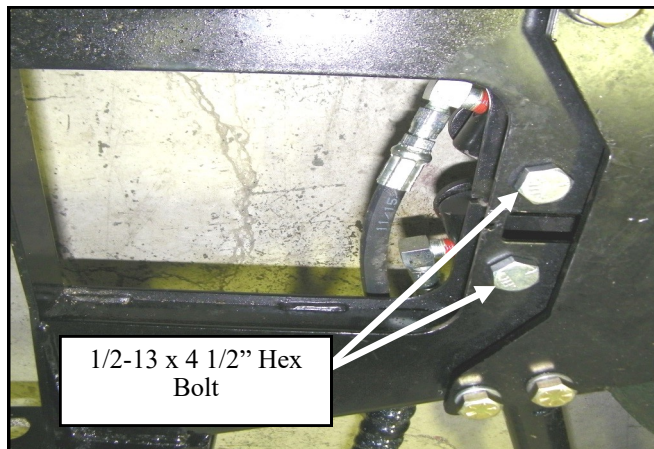

Fig. 9.2 Angle Cylinder
Fixed End

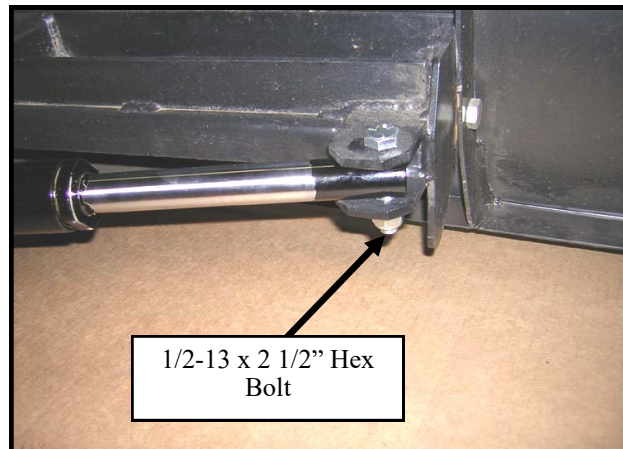

Fig. 9.3 Angle Cylinder
Piston End

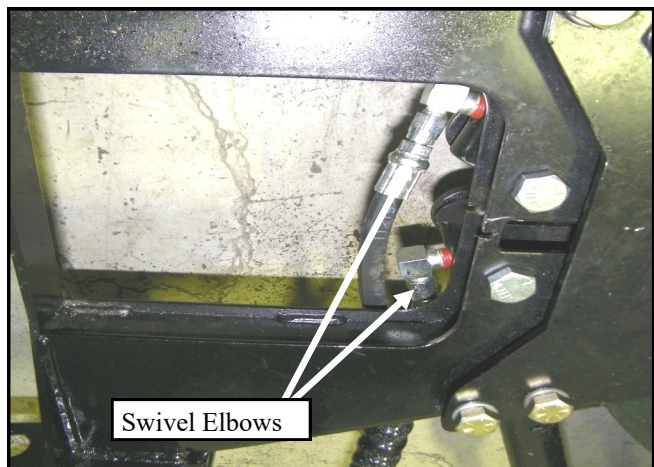

Fig. 9.4 Angle Cylinders fixed End Hose
orientation

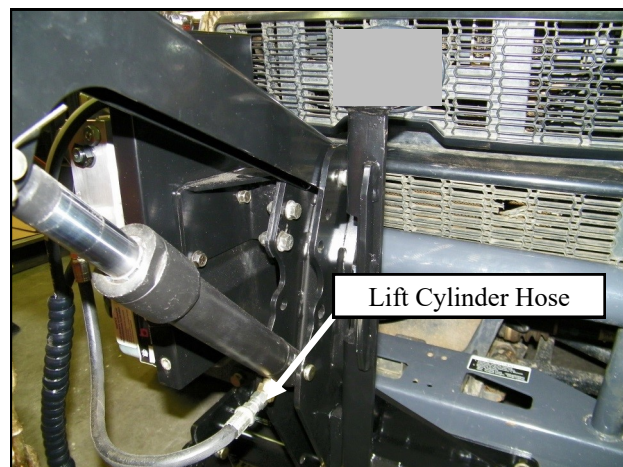

Fig. 9.5 Lift Cylinder Hose orientation

10. FILL THE SYSTEM:

- 10.1 At this point, hook the battery terminals up to the main wiring harness connecting the positive leads first then the negative leads last.
- 10.2 Per fig. 10.2, remove the filler cap and fill tank with electric plow oil (AW 32). Stand clear of the plow. Turn the controller on and then using the controller, work the cylinders left and right and up and down a few times working the air from them, make sure oil is about 1/2" from top of tank. If the oil level in the tank gets low, add to it until the system is bled of air.
- 10.3 Place cover over pump and bracket and attach with (7) 1/4-20 screws provided. See Figure 10.3.
- 10.4 Double check all connections and re-tighten all bolts and unit is ready for operation.

USE ONLY ELECTRIC PLOW OIL (AW 32)

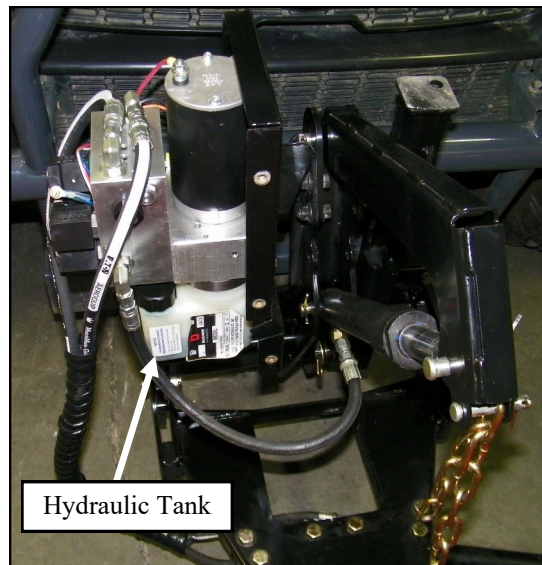

Fig. 10.2 Hydraulic tank



Fig. 10.3 Final Assembly

11. TROUBLE SHOOTING A HYDRAULIC CYLINDER LEAK:

- 11.1 Oil seepage may stop on its own once the dry cylinders are fully cycled several times (5 to 10 times) to get the seals to reset properly. If this does not resolve the issue, proceed to step 11.2.
- 11.2 Disconnect the main wiring harness before servicing.
- 11.3 Per fig. 11.3, loosen the gland nut on the particular leaking cylinder. Additional oil may escape. Take care to place a bucket or rags below the cylinder. Loosening the gland nut will allow the seals to relax and re-align. There is no need to remove the gland nut entirely. **Do not** remove the rod from the cylinder.
- 11.4 Hand tighten the gland nut.
- 11.5 Tighten the gland nut an additional 1/8 to 1/4 turn with a wrench.
- 11.6 Repeat section 10.2 on the previous page to bleed air out of the cylinder. It's important to cycle the affected cylinder several times (5 to 10 times).
- 11.7 Wipe down the cylinder with a rag and inspect for leaking oil.
- 11.8 If necessary, repeat the process of tightening the gland nut an additional 1/8 turn and bleeding the cylinder until free of leaks. Repeat another 1/8 turn if still leaking. Note: proceed only in 1/8 turn increments and continue cycle testing between adjustments.



Fig. 11.3 repairing a Hydraulic Cylinder leak