



**Kawasaki Mule PRO-FXT - A/C Ready  
p/n's: 1KAFXTCACB & 1KAFXTCAS1-ACB  
fits all Mule Pro 6-Pass. models, including model 1000**

*While this cab kit was designed to fit on the vehicle(s) listed above, manufacturing tolerances and vehicle assembly may affect cab fitment. It is the responsibility of the cab installer to check all vehicle pedals and levers for full functionality and, as required, adjust the cab fitment to prevent any interference of the cab components with the travel of pedals or levers.*



Cab Shown with Optional Front Wiper, Lights, and Side View Mirrors

Available Options:

1. Front Wiper Kit (1KAPFXWK)\*
  2. Front LED Work Lights (P/N: 1KAPFXFWL)\*
  3. Rear LED Work Lights (P/N: 1KAPFXRWL)\*
  4. LED Corner Flasher Light Kit (P/N: 1KAPFXCFL)\*
  5. Strobe Light (P/N: 9LEDS2)\*
  6. Interior Dome Light (P/N 9LEDD14)\*
  7. Heater (P/N: 9PH20S61)
  8. Side View Mirrors (P/N: 9PM5)
  9. Rear View Mirror (P/N: 9PM3)
  10. Fuse Panel kit (P/N 1KAPFXFP)
- \* Requires Curtis (P/N 1KAPFXFP) or Kawasaki (P/N KAF080-076) Fuse Panel Kit.

Approximate Installation Time *
Experienced Dealer Technician – 4.5 Hours
Average Dealer Technician – 5.5 Hours
Do-It-Yourself – 6.5 Hours

Approximate Product Specifications
Ground to Top of Air Conditioner: 74 inches
Weight: 447 lbs.
Cab Width: 69-1/2 inches

(\*=Not including accessories)

The contents of this envelope are the property of the owner. Leave with the owner when installation is complete.

Rev. A, 04/05/2024

# TABLE OF CONTENTS

WARNINGS, TIPS, & REQUIRED TOOLS.....	3
CAB INSTALLATION.....	4-21
CAB FEATURES & OPERATION.....	21-22
CARE AND MAINTENANCE.....	22
SERVICE PARTS .....	23-26
OPTIONAL ACCESSORIES .....	27
BOLT TORQUE SPECIFICATIONS .....	28

## WARNINGS, TIPS, & REQUIRED TOOLS

Curtis cabs feature an assembly of parts designed for your vehicle which require adjustment and alignment of components to accommodate vehicle variations and provide proper weather protection. For accurate installation, proper operation, and years of satisfaction, please read and understand the installation and owner's manual fully prior to installing the cab.

From all of us at Curtis, we thank you for choosing our product.



**ADDED WEIGHT NOTICE**

Curtis Cabs, blades and general accessories add additional weight to the base vehicle. All Curtis accessory weights are listed in product brochures. Deduct the accessory's total weight from the vehicle's rated capacity and never exceed the vehicle's rated capacity including driver and passenger.

**WARNING** Exposure to Carbon Monoxide can Cause illness, serious injury or death. Never operate vehicle if suspicious of Carbon Monoxide. Inspect exhaust system for leaks monthly. Leaks can result from loose connections, corrosion, cracks or other damage to the exhaust manifold. If leaks are found, repair or replace exhaust system. Do not use vehicle until repair or replacement is complete.

**WARNING**

**Serious Injury or Death**

	This cab enclosure does not provide protection from rollover or other accidents.
	This cab enclosure does not provide protection from flying objects including golf balls.
	This cab enclosure does not provide protection from lightning. When lightning threatens take cover and do not operate vehicle.

## GENERAL INFORMATION BEFORE YOU START

### HELPFUL HINTS:

- Refer to parts diagram found in the service parts section of this manual to help identify parts during the assembly process.
- To assist with the cab installation, leave all fasteners loose for later adjustment unless otherwise specified.
- Read and understand all instructions before beginning.
- Apply a silicone sealant to seal any minor gaps that may occur due to vehicle variations.
- Use caution to avoid damaging the factory installed threaded inserts or weld nuts. Begin the thread engagement by hand to avoid or correct potential cross threading.
- Make sure the areas where the supplied self-adhesive hook Velcro will be applied are clean and dry and at room temperature for best adhesion.
- Before installing parts with factory installed rubber, make sure the rubber is fully installed onto the parts for proper fit and sealing.
- Plastic washers have been supplied to provide a weather seal under the heads of some exterior bolts. The plastic washer should be installed under each bolt head directly against the outside cab surface. Care should be taken not to over tighten the fasteners and damage the plastic washer.

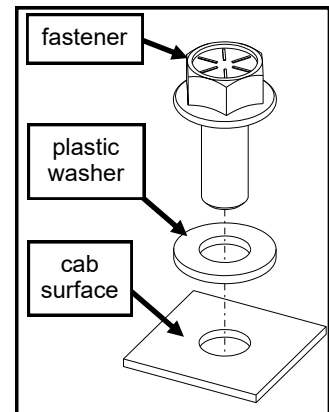

### TOOLS REQUIRED:

- Set of Standard and Metric Sockets (3/8" Drive)
- 3/8" Drive Cordless Ratchet and Long Drive Extension
- Set of Standard and Metric Open-End Wrenches
- #2 and #3 Phillips Head Screwdrivers
- Torque Wrench
- Drill
- 9/32" Drill Bit
- 1-1/4" Hole Saw
- #2 and #3 Phillips Head Bit
- Utility Knife
- Pair of Scissors
- Grease
- C-Clamps
- Silicone Sealant

# CAB INSTALLATION

## SET UP:

Unpack all parts. Leave parts wrapped in felt wrapped so they will be easily identified by their labels. Spread parts around work area as space allows and check for damage. Once inspected, clear area of packing material.

Locate all necessary tools from the list on the previous page and layout on work bench or table before beginning.

Open up the main hardware kit (but not the bag inside it) and separate and organize the hardware.

## STEP 1: (VEHICLE PREP)

**NOTE:** Install alternator kit up to the point of connecting A/C wiring prior to installing CAB. If a heater is to be installed, it will be much easier to install before the cab is installed.

**1.1** Per figure 1.1, remove front and rear half doors.

**NOTE:** Factory hardware and doors are the property of the vehicle owner and should be retained or discarded per the owner's preference.

**1.2** Per figure 1.2, remove factory door latches for front and rear doors.

**1.3** Per figure 1.3, remove all (8) factory door hinges by removing the retaining ring and pin from each hinge. Remove the plastic bushing from the lower front hinge on both sides of the vehicle.

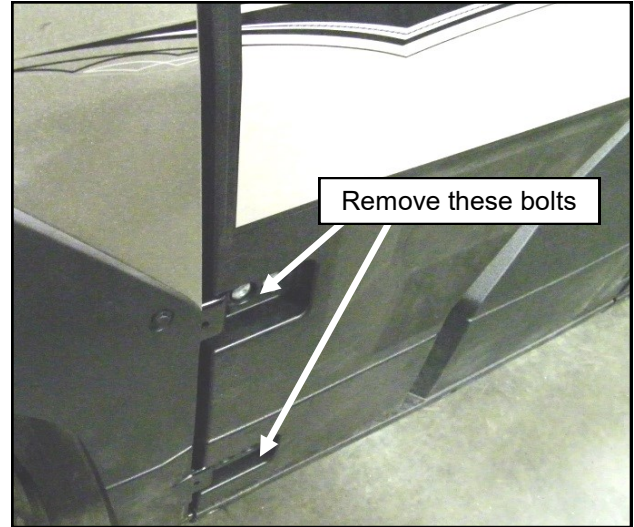

Fig. 1.1 Factory half doors (4)

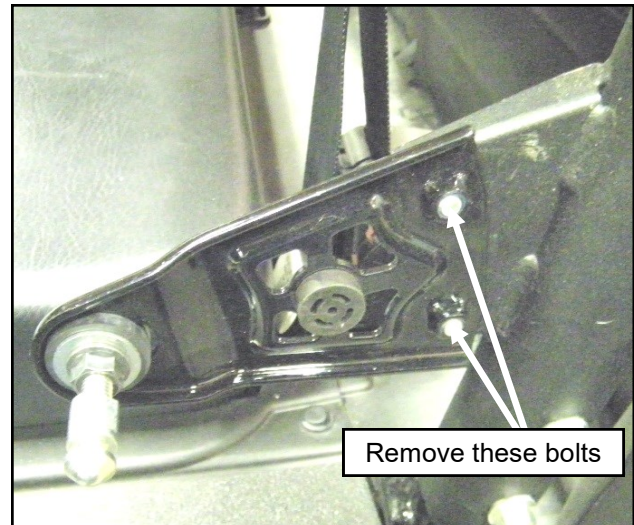

Fig. 1.2 Factory door latches (4)

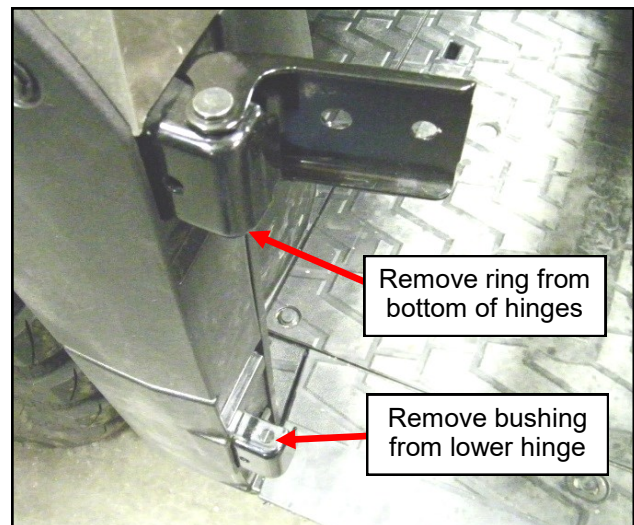

Fig. 1.3 Factory door hinges (8)



# CAB INSTALLATION

## STEP 1: (VEHICLE PREP) Cont'd

- 1.4 Per figure 1.4, remove and discard the two (2) M12 bolts and nuts from each of the front corners of the ROPS (Rollover Protective Structure).
- 1.5 Per figure 1.5, remove and keep battery cover.

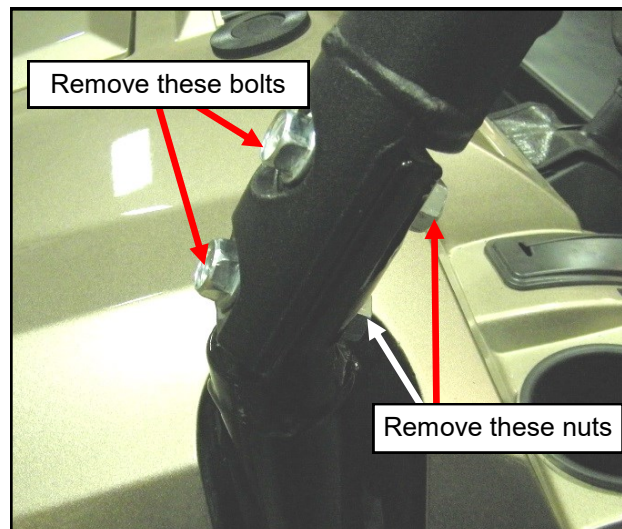

Fig. 1.4 Front ROPS M12 bolts (4)

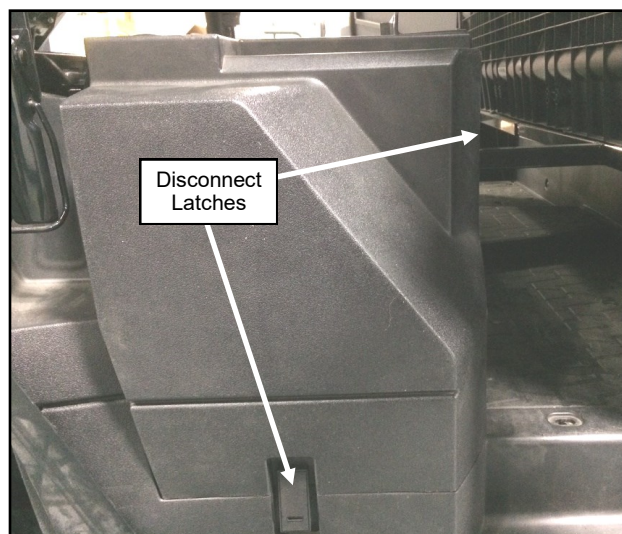

Fig. 1.5 Remove + Keep Battery Cover

## STEP 2: (REAR PANEL BED SEAL)

- 2.1 Convert the rear seat and cargo bed into the 3-seater, extended bed mode. Per figure 2.2, remove the four Phillips screws from the rear base of the seat assembly.
- 2.2 Per figure 2.2, place the rear panel bed seal against the bottom rear of the seat assembly. Install (7) self-drilling screws at the bottom of the slots in the aluminum brush holder of the bed seal.

### Hardware Used

#10 X 3/4 Self-Drilling Screws

### Qty

7

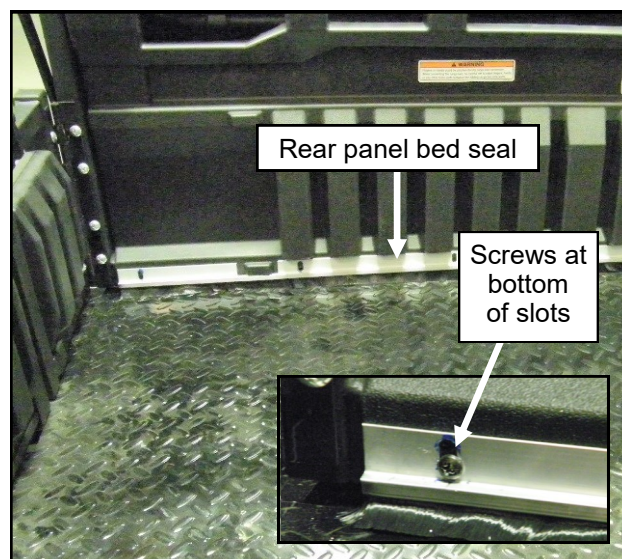

Fig. 2.2 Rear panel bed seal

# CAB INSTALLATION

## STEP 3: (REAR PANEL ASSEMBLY)

- 3.1** Per figure 3.1, remove the rear seat latch mechanism from each side by removing the metric screws at each pivot point. Retain the screws.
- 3.2** Per figure 3.2, place each rear side panel against the side of the seat back assembly. Hold the panel against the corner and approximately centered on the boss for the seat latch, and install (5) self-drilling screws through the side panel and into the seat frame.

<u>Hardware Used</u>	<u>Qty</u>
#10 X 3/4 Self-Drilling Screws	10

- 3.3** Re-install the rear seat latch mechanism with the screws retained in step 3.1. Tighten the M6 and M4 bolts at the latch upper pivot.
- 3.4** Per figure 3.4, place the lower rear panel bracket against the inside of the plastic rear panel, aligned with the slots in the panel, approximately centered on the tube of the rear seat frame.
- 3.5** Remove the protective film from the inside of the plastic rear panel. Per figure 3.5, with assistance, place the plastic rear panel against the rear panel sides and secure with (8) 1/4-20 x 3/4" screws with large steel and rubber washers into the inserts in the side panels and another (2) into the lower rear bracket. The rubber washers should be against the plastic panel. Tighten the (10) 1/4-20 bolts in the rear panel and bracket taking care not to over tighten and damage the rubber washers.

<u>Hardware Used</u>	<u>Qty</u>
1/4-20 X 3/4" Flanged hex bolt	10
1/4" x 1" Rubber Washer	10
1/4" x 1" Steel Washer	10

**CAUTION:** *The hardware kit includes a smaller bag containing four 1/4-20 x 5/8" bolts. These are intended to bolt the windshield latches to the cowl. Set this bag aside and make sure to not use those bolts anywhere else in the cab assembly.*

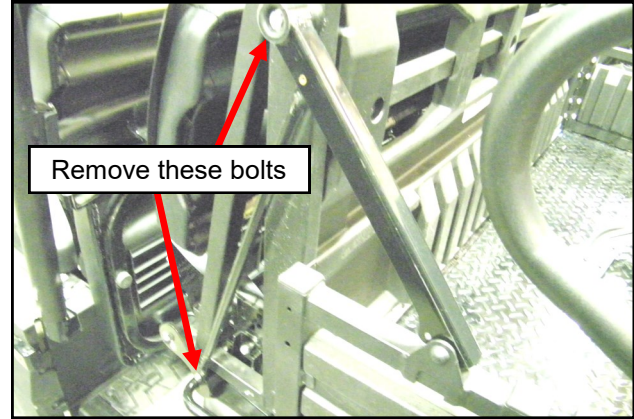

Fig. 3.1 Rear seat latch mechanism

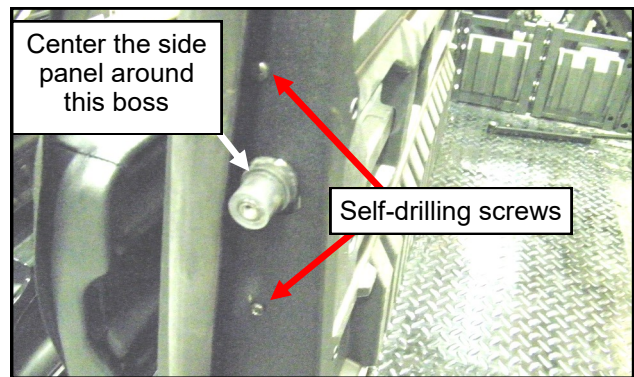

Fig. 3.2 Rear panel sides



Fig. 3.4 Rear panel lower bracket



Fig. 3.5 Plastic rear panel



# CAB INSTALLATION

## STEP 4: (COWL AND A-PILLARS)

- 4.1** Per figure 4.1, place the cowl onto the hood and front ROPS, with the spacers in the bolt pockets in the ROPS.
- 4.2** Per figure 4.2, attach SM-00223 to A-pillar to the lower rear flange of each A-pillar panel using hardware supplied. Leave hardware loose.

<u>Hardware Used</u>	<u>Qty</u>
1/4-20 X 3/4" Flanged hex bolt	4
1/4-20 Flanged Nut	4

- 4.3** Per figure 4.3, place each A-pillar panel on top of the cowl, front ROPS and against the side of the front fenders. Tuck the bulb rubber on the bottom of the cowl under the cowl (toward the inside of the cab) to ensure a good seal and install two of the M12 bolts supplied with the cab through the A-pillar, cowl and ROPS on each side and secure with a nut. Leave bolts loose.

<u>Hardware Used</u>	<u>Qty</u>
M12 x 65mm Flanged Hex Bolt	4
M12 Flanged Lock Nut	4

- 4.4** Per figure 4.4, place one 1/4-20 bolt through the tab of the A-pillar bracket and through the hole in the top of the lower factory hinge mount and secure with a nut. Leave loose.

<u>Hardware Used</u>	<u>Qty</u>
1/4-20 X 3/4" Flanged hex bolt	2
1/4-20 Flanged Nut	2



Fig. 4.1 Cowl

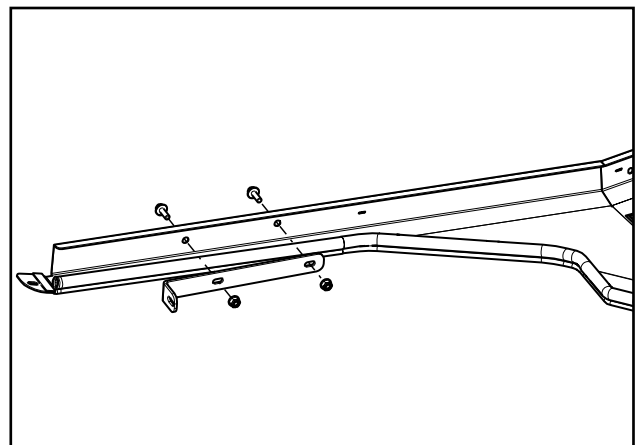

Fig. 4.2 A-pillar brackets

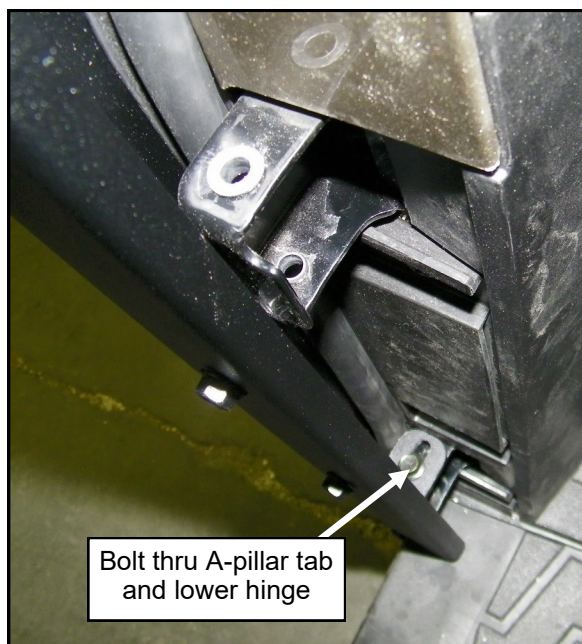

Fig. 4.4 A-pillar bracket to hinge

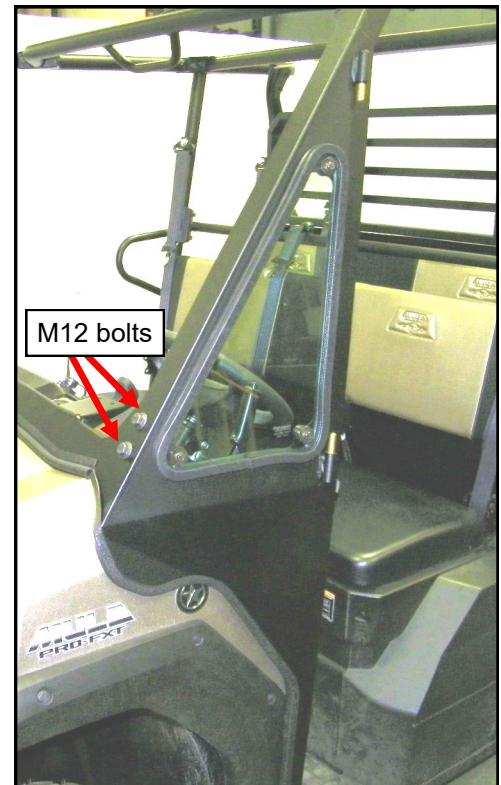

Fig. 4.3 A-pillars

# CAB INSTALLATION

## STEP 5: (B-PILLARS)

5.1 Per figure 5.1, attach the left B-pillar bracket to the front factory latch mounts on the ROPS with (2) 1/4-20 bolts and nuts, with the nuts toward the outside. Leave bolts loose. Repeat for the right side.

<u>Hardware Used</u>	<u>Qty</u>
1/4-20 X 3/4" Flanged Hex Bolt	4
1/4-20 Flanged Nut	4

5.2 Per figure 5.2, place the left B-pillar panel against the center vertical tube of the ROPS and align the holes in the panel to the threaded inserts of the B-pillar bracket. Insert (3) 1/4-20 bolts with washers on the outer bolts into the threaded inserts and leave loose. Place one 1/4-20 bolt with washer through the hole in the lower B-pillar and through the lower rear hinge and secure with a nut inside, leave loose. Repeat for the right side.

<u>Hardware Used</u>	<u>Qty</u>
1/4-20 X 3/4" Flanged Hex Bolt	8
1/4" X 1" Steel Washer	6
1/4-20 Flanged Nut	2

## STEP 6: (C-PILLARS)

- 6.1 If installing on an 800 vehicle, skip this step. If installing on a 1000 vehicle, remove the knock-out tab from just the right side C-Pillar to clear air intake that is welded to the ROPS. See figure 6.1 below.
- Temporarily peel back the rubber flap several inches from the area shown.
  - Break out the knock-out tab and discard.
  - Use touch-up paint on the small exposed metal connection points.
  - Do not cut rubber. Leave bottom peeled off until installed on vehicle.

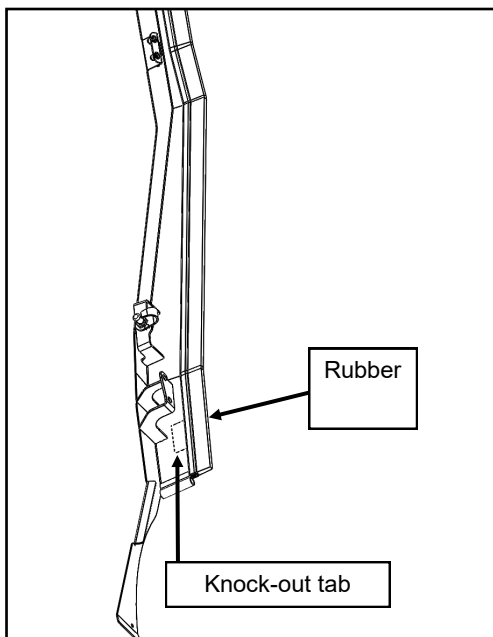

Fig. 6.1 (C-pillar panel, for right side only)

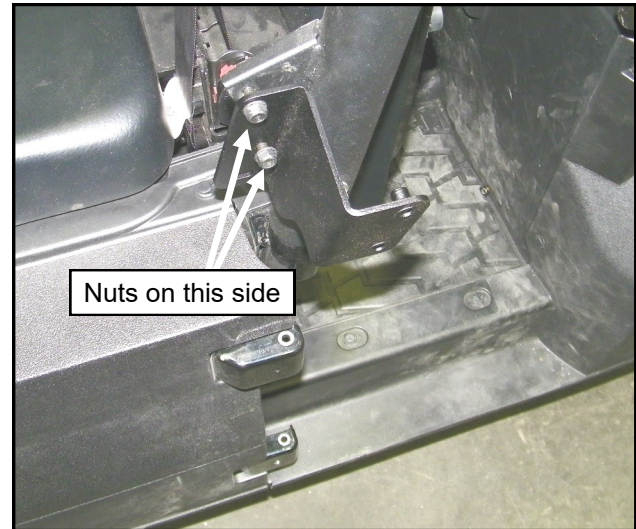

Fig. 5.1 B-pillar brackets

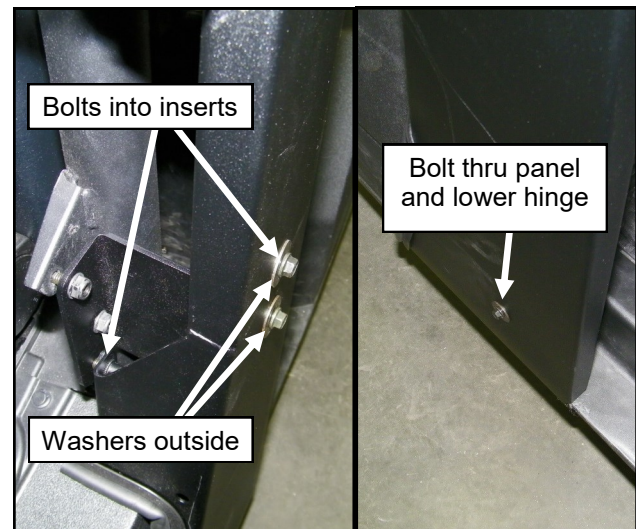

Fig. 5.2 B-pillar panel



# CAB INSTALLATION

## STEP 6: (C-PILLARS)

- 6.2** Per figure 6.2, adhere 1/2" x 9/16" foam rubber to the rear and bottom edges of the left and right C-pillar lower flange.
- 6.3** Raise and secure the cargo bed. Per figure 6.3, attach the left and right C-pillars to the rear factory latch mounts on the ROPS with (2) 1/4-20 bolts and nuts per side, with the nuts toward the outside.

<u>Hardware Used</u>	<u>Qty</u>
1/4-20 X 3/4" Flanged Hex Bolt	4
1/4-20 Flanged nut	4

- 6.4** Per figure 6.4, attach the C-pillar bracket around the ROPS and to the left and right C-pillars with (3) 1/4-20 bolts per side. Leave bolts loose. Repeat for the right side.

<u>Hardware Used</u>	<u>Qty</u>
1/4-20 X 3/4" Flanged Hex Bolt	6

- 6.5** For FXT 1000, re-install the rubber onto the edge of the part on the inside of the air intake bracket after the part is installed onto the vehicle so the rubber remains a continuous piece from top to bottom.

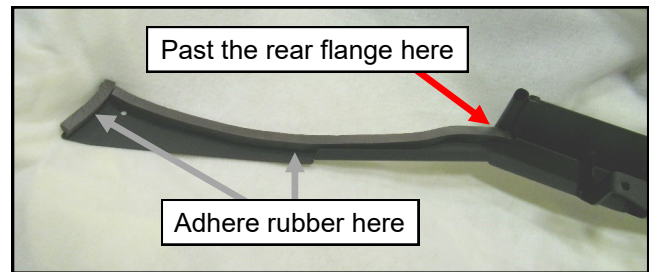

Fig. 6.2 C-pillar foam rubber



Fig. 6.3 C-pillar

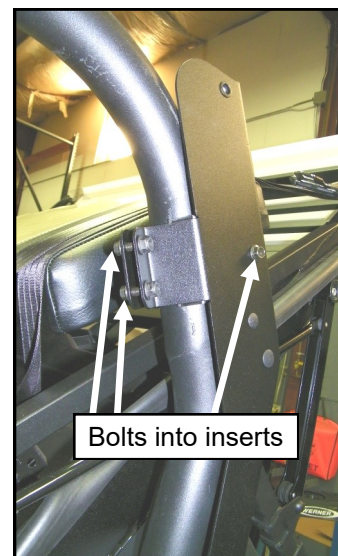

Fig. 6.4 C-pillar

# CAB INSTALLATION

## STEP 7: (HEADERS)

- 7.1 Per figure 7.1, place the left Header on top of the upper left ROPS and align the holes in the upper flange of the panel to the holes in the ROPS. Insert a 1/4-20 bolt with washer into the threaded inserts in the A-Pillar and C-pillar and leave loose. Repeat for the right side.

### Hardware Used

	Qty
1/4-20 X 3/4" Flanged Hex Bolt	4
1/4" X 1" Steel Washer	4

- 7.2 Per figure 7.2, attach the header to the B-pillar with (2) 1/4-20 bolts and nuts per side, with nuts on the inside of the panel. Leave loose.

### Hardware Used

	Qty
1/4-20 X 3/4" Flanged Hex Bolt	4
1/4-20 Flanged Nut	4

## STEP 8: (CANOPY GAS SPRING BRACKET)

- 8.1 Cut the supplied piece of 1" x 3/4" foam in half to make two pieces approximately 4 inches long. Per figure 8.1, apply the foam to the center of the inside corner of the left and right gas spring brackets.

- 8.2 Per figure 8.2, remove the (2) M10 bolts at the center ROPS cross tube, the farthest to the front and rear, from the left (driver's side) end of the cross tube. Place the left gas spring bracket against the ROPS as shown and secure it with new, longer M10 bolts and leave loose.

### Hardware Used

	Qty
M10x1.25 x 20mm Flanged Hex Bolt	4

- 8.3 Per figure 8.2, insert one 1/4-20 bolt through the mount and into the insert in the header and leave loose. Install (3) 1/4-20 bolts through the B-pillar upper flange into the threaded inserts in the gas shock bracket and leave loose.

### Hardware Used

	Qty
1/4-20 X 3/4" Flanged Hex Bolt	4

Repeat steps 8.1 through 8.3 for the other side.

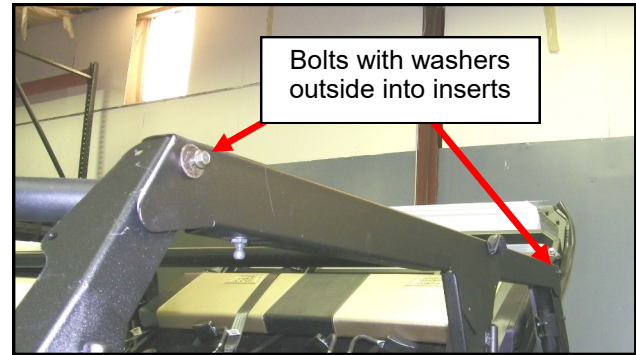

Fig. 7.1 Header placement

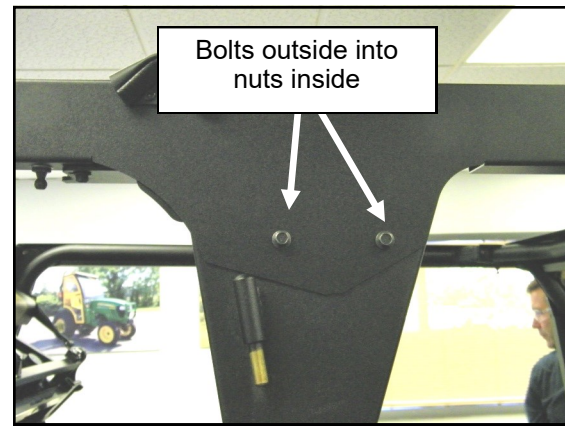

Fig. 7.2 Header to B-pillar

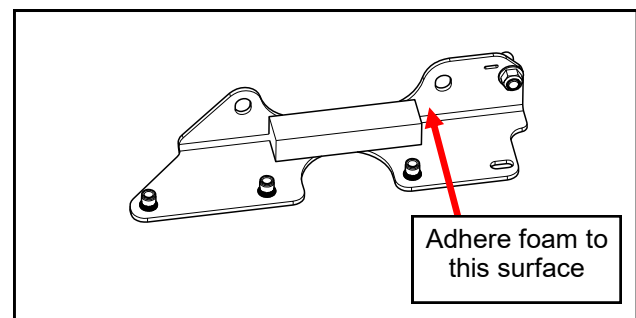

Fig. 8.1 Gas spring bracket foam

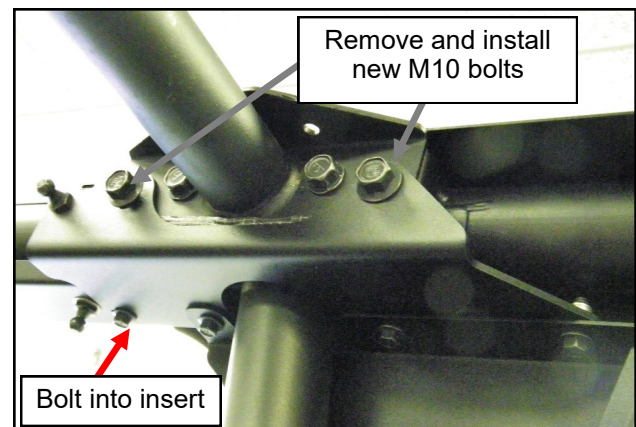

Fig. 8.2 Canopy gas spring bracket

# CAB INSTALLATION

## STEP 9: (WINDSHIELD SUPPORT)

9.1 Per figure 9.1, place the windshield support on top of the headers and A-pillars. Attach the windshield support to each A-pillar with a 1/4-20 bolt and nut. Tighten these bolts.

Hardware Used	Qty
1/4-20 X 3/4" Flanged Hex Bolt	2
1/4-20 Flanged Nut	2

9.2 Ensure the edges of the cowl and A-pillar line up and no gaps are visible in the rubber under the cowl, then tighten the (4) M12 bolts shown in figure 4.3 on page 7.

**WARNING:** In order for the Rollover Protective Structure to provide proper protection in the event of a roll over, the (4) M12 bolts at the sides of the cowl must be tightened to a torque of 100 ft.-lbs. (135 N-M).

## STEP 10: (WINDSHIELD)

10.1 Per figures 10.1a and b, place a hinge spacer block onto the windshield hinge and two flat head 5/16" bolts through each hinge. **Note: for glass windshields, use the thinner 5/8" thick hinge spacer blocks found in the windshield box. For polycarbonate windshields, use the thicker 3/4" thick hinge spacer blocks found in the hardware box.** Place the windshield onto the windshield support with the bolts through the slots and secure with 5/16" nuts.

Hardware Used	Qty
5/16-18 x 1-1/2 Flat Head Bolt	4
5/16-18 Flanged Nut	4

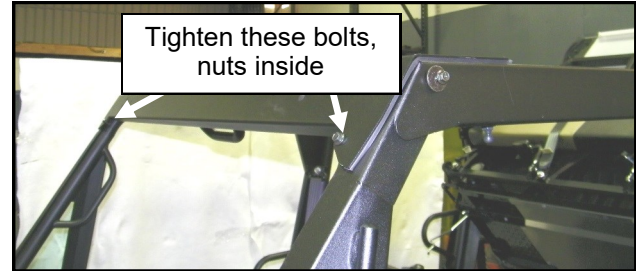

Fig. 9.1 Windshield support

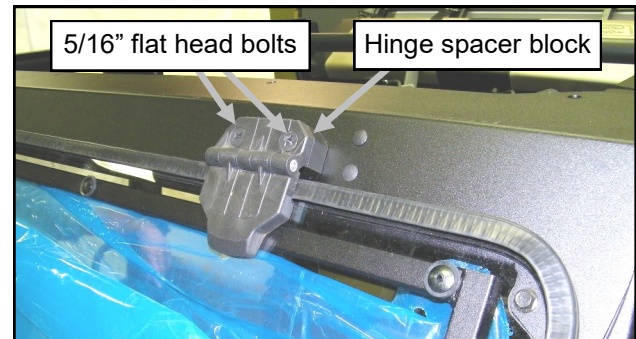

Fig. 10.1a Windshield, outside

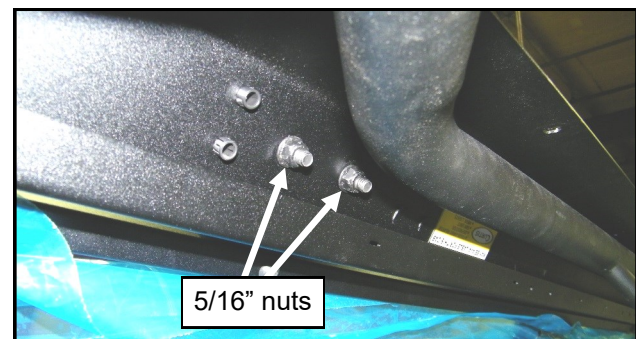

Fig. 10.1b Windshield, inside



# CAB INSTALLATION

## STEP 10: (WINDSHIELD) Cont'd.

- 10.2** For a polycarbonate windshield, skip to step 10.4.  
For a glass windshield, install the shorter gas springs onto the ball studs on the windshield frame. Per fig. 10.2, orient them so that the piston rod is pointing downwards.
- 10.3** For a glass windshield, install the latches to the windshield frame, oriented as shown in fig. 10.3.
- 10.4** Per fig. 10.4, attach each latch bracket to the cowl with (2) 1/4-20 x 5/8" bolts and nuts and tighten.

<u>Hardware Used</u>	<u>Qty</u>
1/4-20 x 5/8" Flanged Hex Bolt	4
1/4-20 Flanged Nut	4

- 10.5** Lift up on the bottom of the windshield and close the windshield latches. Check the windshield fit. If any gaps are visible under the windshield rubber, adjust the windshield hinges up or down as needed to remove the gaps. Tighten the (4) windshield hinge bolts (5/16-18 flat head screws) to 7 ft.-lbs. max.

**CAUTION:** The torque applied to the windshield hinge bolts is reduced to prevent cracking the countersunk holes in the plastic hinges.

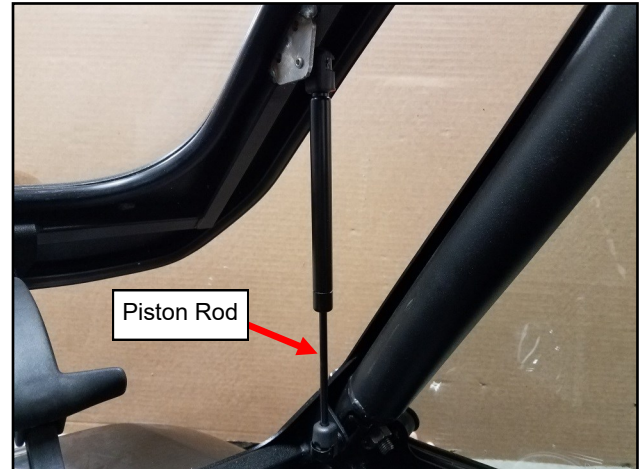

Fig. 10.2 Windshield gas springs

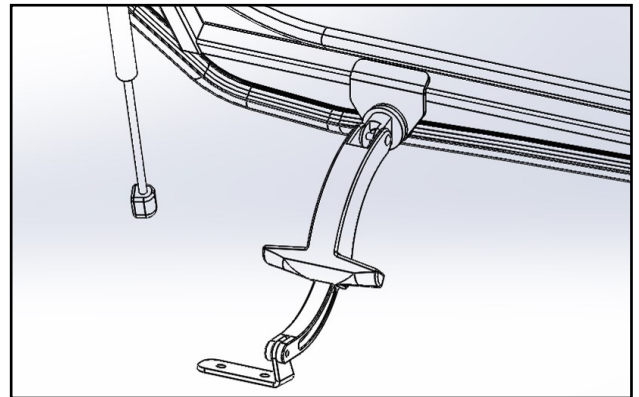

Fig. 10.3 Windshield latch orientation

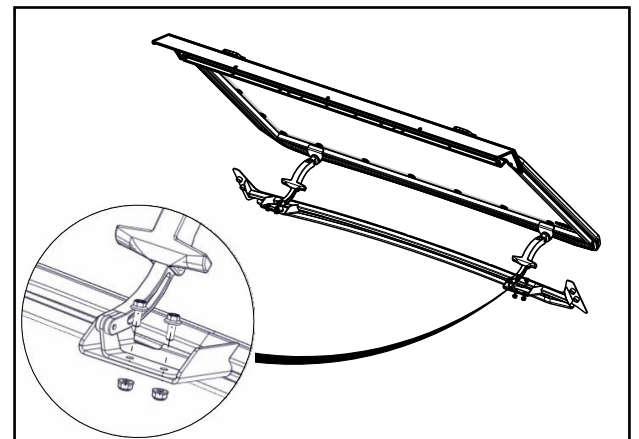

Fig. 10.4 Windshield latch fasteners



# CAB INSTALLATION

## STEP 11: (INSTALL A/C UNIT)

**CAUTION:** Never turn the air conditioner upside down or on its side. Doing so will drain the compressor of its oil and will void the warranty.

**Note:** Ensure the main power harness and relay harnesses have been installed in the A/C unit as per the Alternator Kit install manual.

- 11.1 With assistance, place the air conditioner unit onto the roof, center it inside of the roof's rectangular opening. See figure 11.1.

**Note:** Determine how vehicle will be used most often.

If the single seat configuration is more often used, orient the unit so the vents are closer to the front edge.

If the 2-row configuration is more often used, orient the unit as shown when installing so the vents are closer to the back edge.

Loosely install all fasteners to the roof and air conditioner along the perimeter of the air conditioner so that the smaller diameter plastic washers are under the heads of the screws and the larger diameter steel washers are between the lock nuts and headliner. Once all screws are installed, they can be tightened and nut covers installed.

<u>Hardware Used</u>	<u>Qty</u>
1/4-20 x 3/4" flange bolt	18
1/4" x 3/4" OD plastic washer	18
1/4" x 1" OD steel washer	18
1/4-20 flanged lock nut	18
1/4" nut caps	18

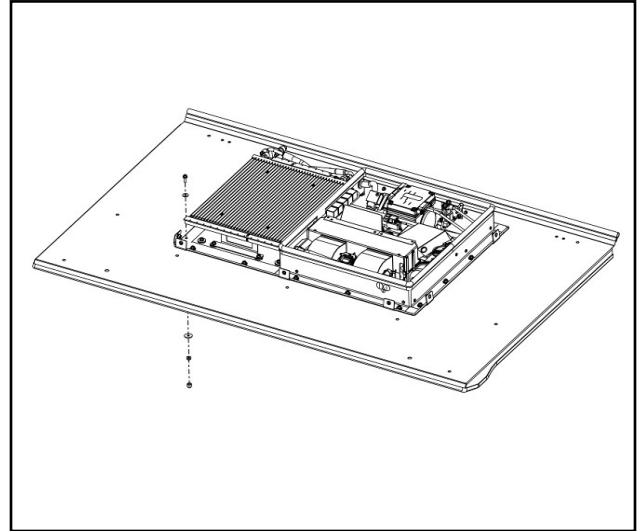

Fig. 11.1 Install A/C Unit

# CAB INSTALLATION

## STEP 12: (FRONT CANOPY)

- 12.1** If required, use an awl or large screwdriver to poke a hole through the headliner at each hole in the front canopy. Poke through the headliner side so as not to separate the headliner from the metal canopy.
- 12.2** Per figure 12.2, place the front canopy on top of the cab and align to the holes in the headers and windshield support. Insert the longer 1/4-20 bolts with plastic washers through the outer, front holes in the canopy, through the holes in the ROPS and through the lower flange of the headers and secure with nuts. Insert shorter 1/4-20 bolts with plastic washers through the remaining holes through the canopy as shown and secure with nuts.

<b>Hardware Used</b>	<b>Qty</b>
1/4-20 X 2-1/2" Flanged Hex Bolt	2
1/4-20 X 3/4" Flanged Hex Bolt	5
5/16" Nylon washer	7
1/4-20 Flanged Nut	7

- 12.3** Install P-clamps onto the vehicle's ROPS per fig. 12.3. Next, loosely install all fasteners to the roof so that the smaller diameter plastic washers are under the heads of the screws and the larger diameter steel washers are between the P-Clamps and headliner.

<b>Hardware Used</b>	<b>Qty</b>
1/4-20 X 1" Flanged Hex Bolt	2
1/4-20 Flanged Nut	2
1/4" x 3/4" OD plastic washer	2
1/4" x 1" OD steel washer	2
1-3/4" P-CLAMP	2

## STEP 13: (ADJUSTMENT AND TORQUE)

- 13.1** Torque the (7) bolts in the front canopy to 5 ft-lbs. (6.8 N-m).

**Caution:** *The torque applied to the canopy bolts is reduced to prevent damage to the plastic washers.*

- 13.2** At the rear canopy gas spring mounts, tighten the (4) M10 bolts and the (2) 1/4-20 bolts into the header.
- 13.3** Align the B-pillar upper rear flange flush to the side header per figure 13.3 and tighten the (5) bolts for each B-pillar to the side header.
- 13.4** Tighten the (5) bolts in each C-pillar.
- 13.5** Tighten the bolts between the left and right header and the A-pillar.

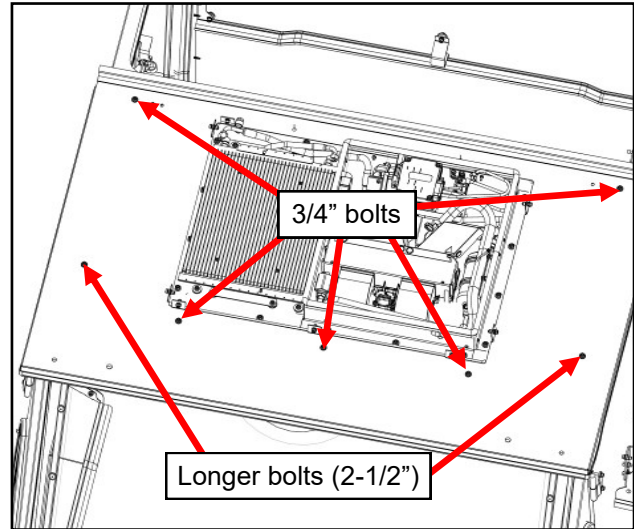

Fig. 12.2 Front Canopy

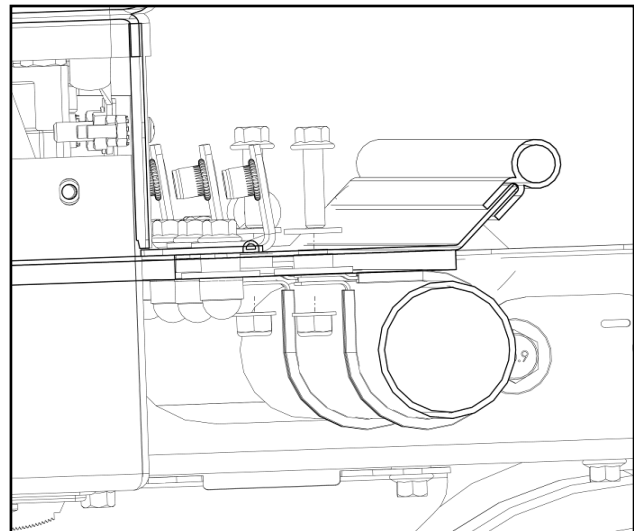

Fig. 12.3 Install P-Clamps onto ROPS

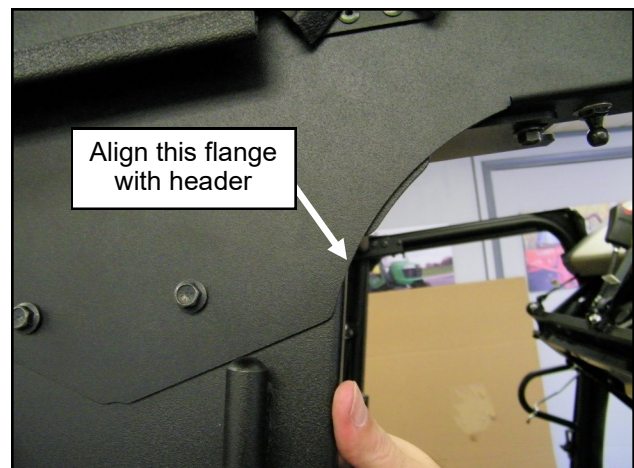

Fig. 13.3 B-panel alignment

# CAB INSTALLATION

## STEP 14: (C-PILLAR LOWER BOLTS)

**14.1** Ensure the cargo bed is still in the raised and locked position, and remove the battery cover at the passenger's side seat base. Per figure 14.1, drill a 9/32" hole through the lower hole in the C-pillar and through the plastic panel underneath. Secure the C-pillar to the plastic panel with a 1/4-20 bolt outside, and steel washer and nut inside the plastic panel and tighten snug.

<u>Hardware Used</u>	<u>Qty</u>
1/4-20 X 3/4" Flanged Hex Bolt	2
1/4" X 1" Steel Washer	2
1/4-20 Flanged Nut	2

**NOTE:** the battery cover may be re-installed or left off at this time to allow wiring of accessories.

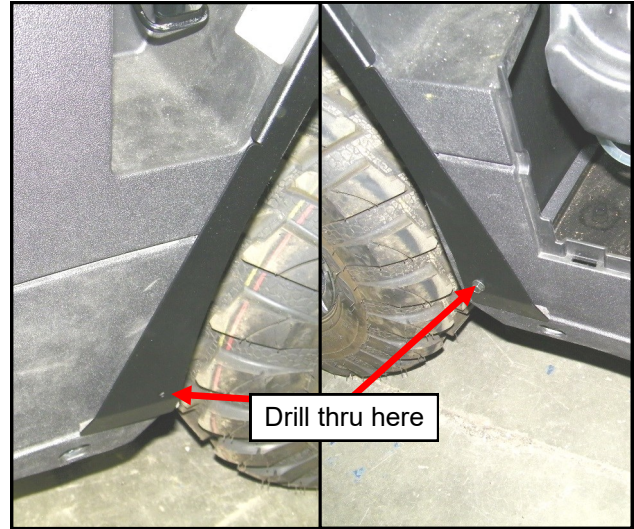

Fig. 14.1 C-pillar lower bolt

## STEP 15: (FUEL FILLER COVER)

**15.1** Per figure 15.1, place the fuel filler cover panel onto the right side B-pillar and insert (2) 1/4-20 bolts into the threaded inserts. Align the outer flange of the fuel filler cover to the side of the B-pillar and tighten the bolts.

<u>Hardware Used</u>	<u>Qty</u>
1/4-20 X 3/4" Flanged Hex Bolt	2

**15.2** Per figure 15.2, on the passenger's side, place the front flange of the fuel filler cover against the lower flange of the A-pillar and install a self-drilling screw through the slots at the front of the fuel filler cover and lower flange of the A-pillar. Install a second self-drilling screw through the hole at the rear of the lower flange of the fuel filler cover. On the driver's side, install a self-drilling screw through the lower flange of the A-pillar.

<u>Hardware Used</u>	<u>Qty</u>
#10 X 1-1/4 Self-Drilling Screws	3

**15.3** Per figure 15.3, tighten the (2) 1/4-20 bolts holding the lower tab to the A-pillar, tighten the lower bolt to the vehicle door hinge mount.

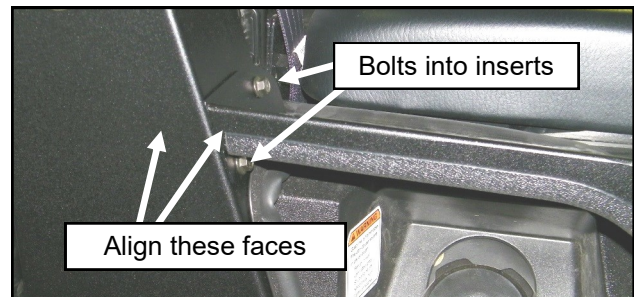

Fig. 15.1 Fuel filler cover

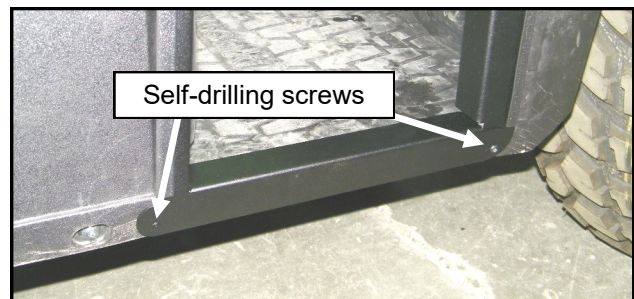

Fig. 15.2 Fuel filler cover

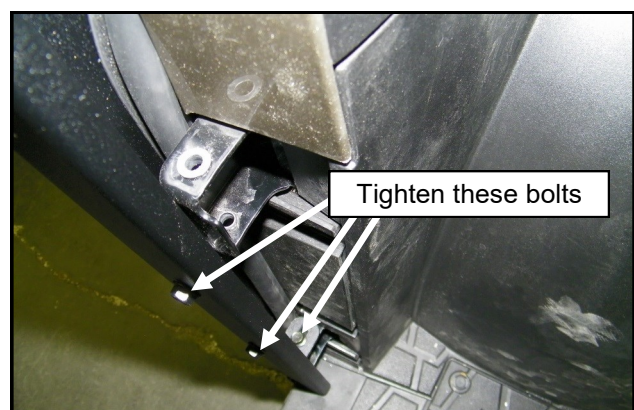

Fig. 15.3 A-pillar lower bracket



# CAB INSTALLATION

## STEP 16: (REAR CANOPY)

**16.1** Per figure 16.1, loosen the (2) 1/4-20 bolts for each hinge on the front of the rear canopy. Apply pressure to the hinge down towards the front edge of the canopy and tighten the bolts.

**16.2** Per figure 16.2, place the rear canopy onto the cab and align the front and rear canopies. If necessary, loosen the rear flange on the rear canopy to allow the front and rear canopies to contact, and re-tighten after the hinges are tight. Place a hinge sleeve over each hinge pin and secure the hinge to the front canopy with (2) 1/4-20 bolts and nuts underneath. Apply forward pressure on the rear canopy against the front canopy and tighten the bolts.

<u>Hardware Used</u>	<u>Qty</u>
1/4-20 X 3/4" Flanged Hex Bolt	2

**NOTE:** Plastic washers are not used on the hinges for the front and rear canopies to allow a higher level of torque on the bolts.

**16.3** Per figure 16.3, attach the cylinder end of the shorter gas springs onto the ball studs on the latch mounts under the rear canopy. **NOTE: orient the piston rod down as shown for best, continuous lubrication and longest gas spring life.** Lift up on the rear canopy, and connect the other end of the gas springs to the ball studs on the gas spring mounts near the rear of the front canopy.

**NOTE:** A gap of around 1/8" is expected between the front and rear canopies due to hinge clearance and gas spring pressure. Remove the gas springs and re-adjust the canopy hinges if the gap exceeds 1/4".

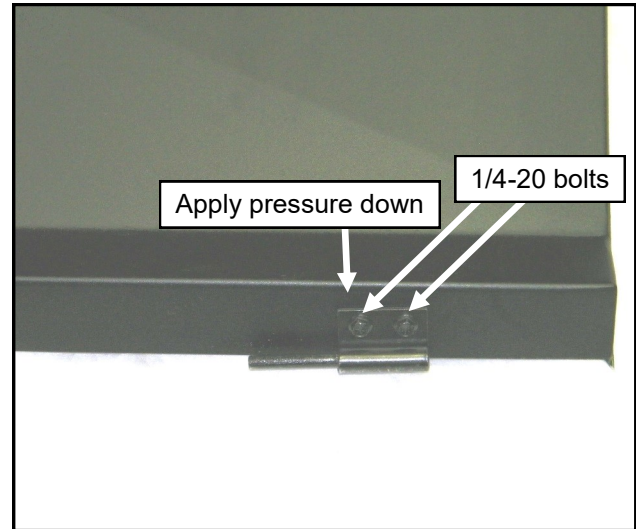

Fig. 16.1 Rear canopy hinges

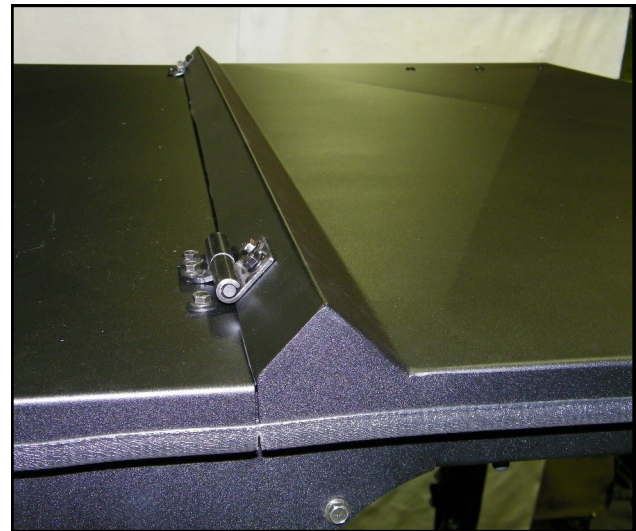

Fig. 16.2 Rear canopy



Fig. 16.3 Rear canopy gas springs



# CAB INSTALLATION

## STEP 17: (DOORS)

**17.1** The doors are packaged with the removable sliding windows installed. Per figure 17.1, remove the sliding windows to ease assembly. To do so, loosen the thumb screws at the bottom of the sliding window.

**17.2** Apply general purpose grease onto the door hinge pins on the A and B pillars.

**17.3** The Lower Hinge sleeves will be found on the door, and the left and right upper hinge sleeves will be found in the Hardware Box. The door's striker bolt (assembled to the B & C -Pillars) should be centered in its slot, ensure that this is so before proceeding.

**17.4** Install a brass washer to the lower hinge of the driver's side A-Pillar. Place the driver side door onto the lower hinge of the driver side A-Pillar. Latch the door, then install a brass washer and the upper hinge sleeve to the A-Pillar. Then bolt the left hinge sleeve to the door. Wipe away any excess grease from the hinges. See figure 17.4

<u>Hardware Used</u>	<u>Qty</u>
Brass Washer	2
1/4-20 x 1.5" Flanged Hex Bolt	2
1/4-20 Flanged Nut	2

**17.5** A properly adjusted door will yield two audible "clicks" when the door is shut.

### Adjustment:

- | Adjustment:                      | Result:                            |
|----------------------------------|------------------------------------|
| • Hinges/Striker pin up/down     | Door alignment to cab              |
| • Striker pin in                 | Tighter door seal                  |
| • Striker pin out                | Easier latch double click          |
| • Latch forward/back (fig. 17.5) | Latch pawl centered on striker pin |

**17.6** Repeat steps 17.4 & 17.5 for the remaining doors.

**17.7** Install the remaining gas springs on the doors with the piston end on the door to keep it lower than the cylinder and lubricated like the roof gas springs.

**17.8** Insert plastic plugs in inside hole of the door's Mirror installation holes. Skip this step if a Mirror Kit is to be installed to the vehicle.

<u>Hardware Used</u>	<u>Qty</u>
3/4" Plastic Plug	4

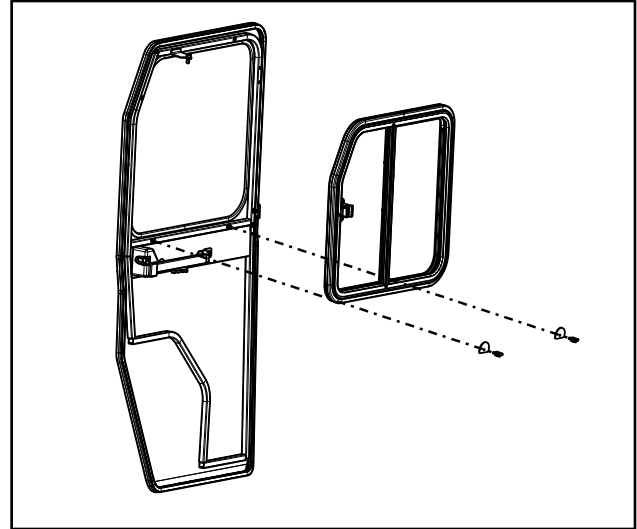

Fig. 17.1 Removable sliding windows

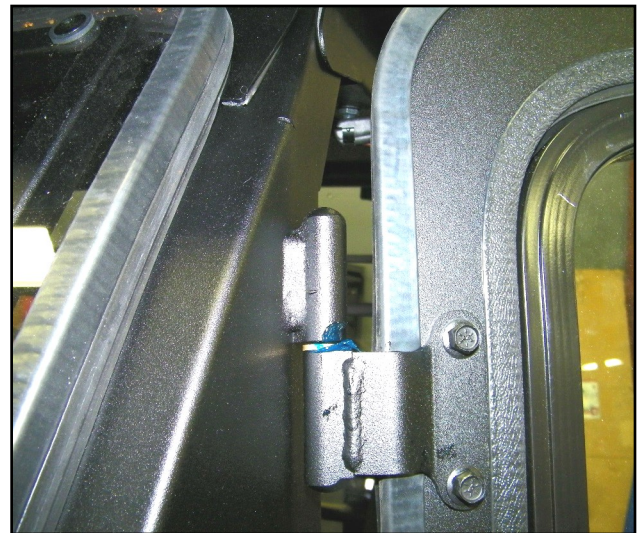
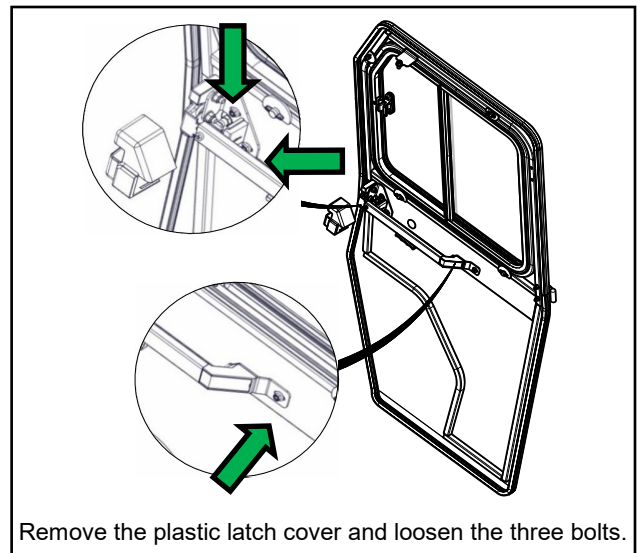

Fig. 17.4 Assembled Hinge



Remove the plastic latch cover and loosen the three bolts.

Fig. 17.5 Inside Latch Fasteners

# CAB INSTALLATION

## STEP 18: (ROUTE POWER HARNESS)

**18.1** Cut marked corner (1-1/4" Hole Saw and Snips) of the plastic located on the rear side of the panel under the passenger seat as shown in figure 18.1. Cut and apply 3-3/4" long trim-lok onto the bottom edge of the center ROPS tube per fig. 18.1 to protect the wire. The trim-lok is located in the alternator kit.

### Tools

Drill and 1-1/4" hole saw  
Snips

**18.2** Route the wire harness along the center ROPS cross tube and turn to route down the passenger side ROPS tube as shown in Figure 18.2a and 18.2b. Ensure that the harness is outside and behind the upper seat belt mount.

**18.3** Continue to route the wire harness down the center ROPS tube and pass behind it to get behind the seat. Per fig. 18.3.

**18.4** Route the harness through the recently cut opening (step 18.1) underneath where the ROPS mounts to the vehicle.

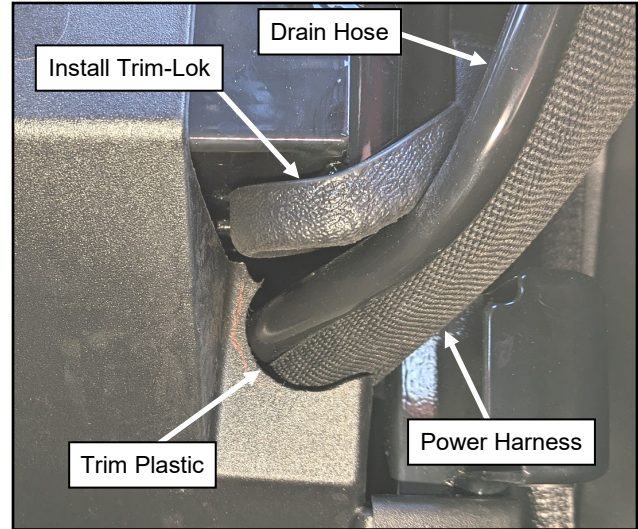

Fig. 18.1 Front Seat Cover, Right



Fig. 18.2a Route Harness

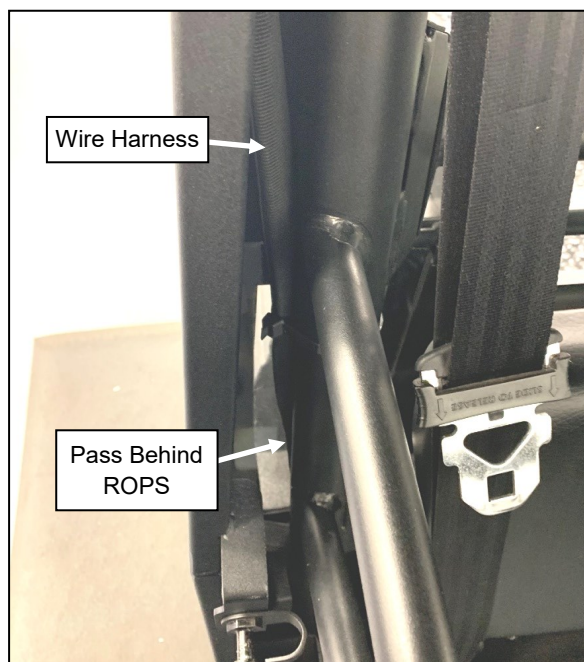

Fig. 18.3 Route Harness



Fig. 18.2b Route Harness



## CAB INSTALLATION

### STEP 18: (ROUTE POWER HARNESS) Cont'd.

- 18.5** Route the harness behind the fuel tank to a frame channel running down the middle of the vehicle as shown in figure 18.5. Continue to route the harness back towards the battery compartment within this frame channel.
- 18.6** Route the harness up to the positive battery lug as shown in figure 18.6.
- 18.7** Secure the harness with the supplied cable ties. Leave ties loose at this time to allow drain hose to be routed along side the harness.

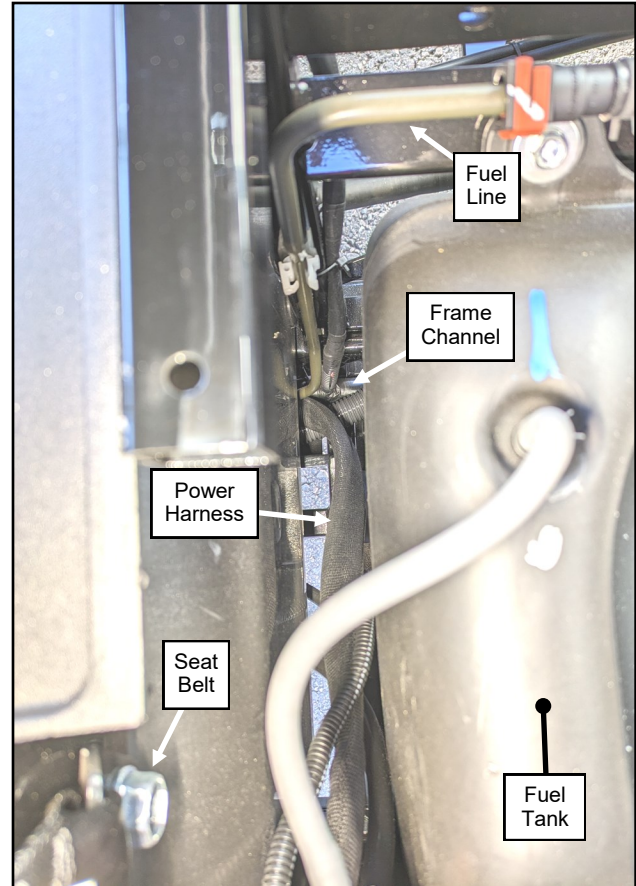

Fig. 18.5 Route Harness, Right Side

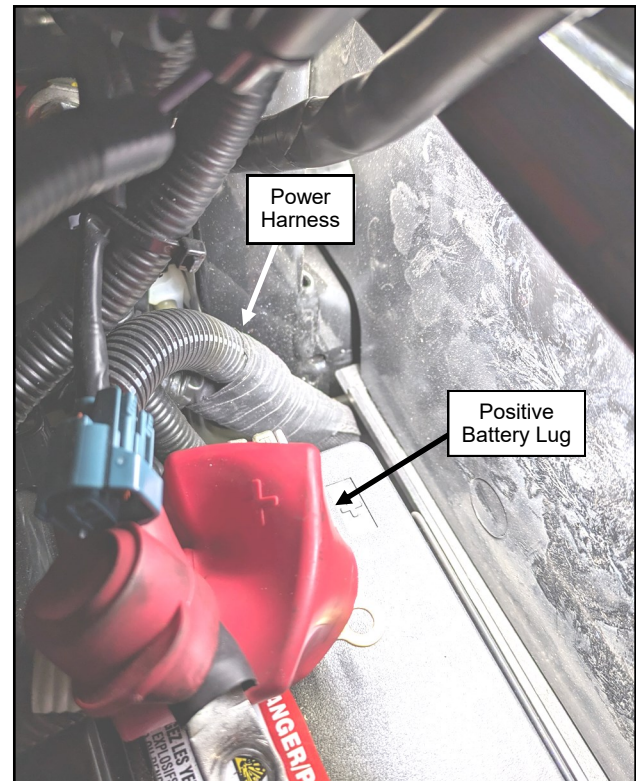

Fig. 18.6 Route Harness, Right Side

# CAB INSTALLATION

## STEP 19: (DRAIN HOSE)

**19.1** Locate the black drain tube included in the alternator kit. Attach drain tube to the side of the air conditioner on the passenger's side of the vehicle. If required, rotate the nipples towards the rear of the vehicle at a slight downward angle. See fig. 19.1.

Secure the hose to the rear corner using a supplied P-Clamp and self drill screw. Ensure the hose is running downhill to drain properly.

Repeat this step for the opposite side of the vehicle.

Tip: Apply a little water to the nipple to lubricate and ease the installation of the drain tube.

<u>Hardware Used</u>	<u>Qty</u>
PVC Tube, 3/8" Inside Dia.	2
#10 x 1/2" Self-Drill Screw	2

Tools  
Drill with #2 Phillips bit

**19.2** Route the Air Conditioner's drain tube rearward and down along the rear ROPS tube alongside the main power harness. Run the hose out of the cab and down under the vehicle. Mirror the routing for the opposite side. Secure with cable ties at this time. See figures 19.2a-c.

**Important:** Be sure that the drain hose is free from kinks and that the path is always **lower** than where it exits the air conditioner in order to prevent backups and internal leaks.

<u>Hardware Used</u>	<u>Qty</u>
11" Cable ties	10

Tools  
Scissors or Snips

**19.3** Install the slitted-rubber Tube Caps supplied in the alternator kit on the lower end of the two drain tubes by sliding on. See fig 19.3.

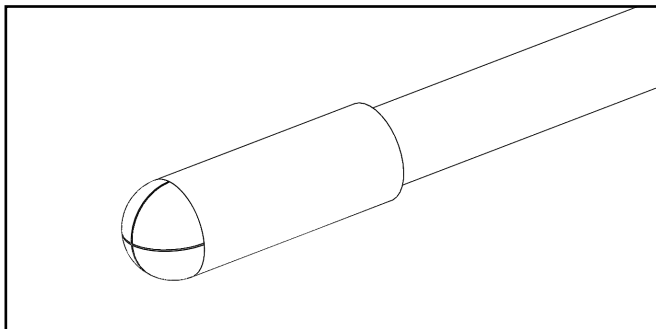

Fig. 19.3 Tube Cap

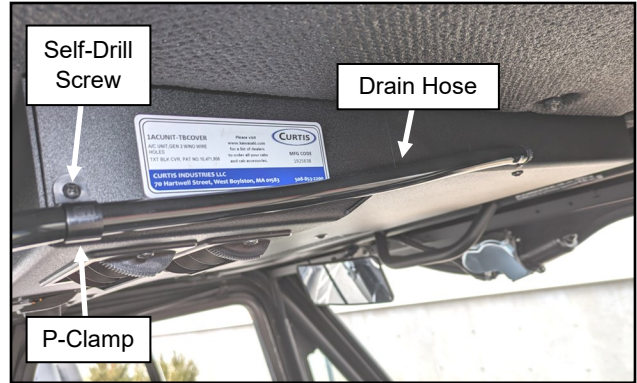

Fig. 19.1 Connect Drain Tube, Right Side



Fig. 19.2a Route Drain Tube, Right Side



Fig. 19.2b Route Drain Tube, Left Side



Fig. 19.2c Route Drain Tube, Left Side



# CAB INSTALLATION

## STEP 20: (FINAL STEPS)

**20.1** Electrically connect the air conditioner and test its operation by following the installation instructions provided with the A/C Alternator Kit.

**20.2** Per figure 20.2, re-install cover to air conditioner. Use anti-seize on all screws and bolts when fastening the cover. Poke a hole through the insulation and install the M6 screw first, then re-install the 1/4-20 bolts. Tighten 1/4-20 bolts to 5 ft-lbs and tighten M6 screw until the rubber washer begins to bulge.

<b>Hardware Used</b>	<b>Qty</b>
1/4-20 x 3/4" flange bolt	10
M6X1 X 16mm truss head screw	1
M6 Rubber Washer	1

**20.3** Re-install battery cover.

**20.4** Ensure all doors and windshield close and latch reliably with no visible gaps. Re-adjust if necessary.

**20.5** Remove the protective film from the outside of the rear panel and the inside and outside of the windshield.

**20.6** If no accessories are installed, use supplied dome plugs to plug any holes in cab components.

**20.7** Secure any loose fasteners or wires.

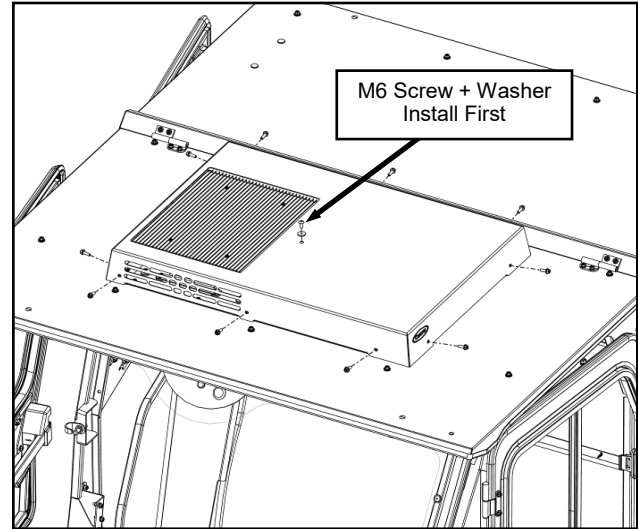
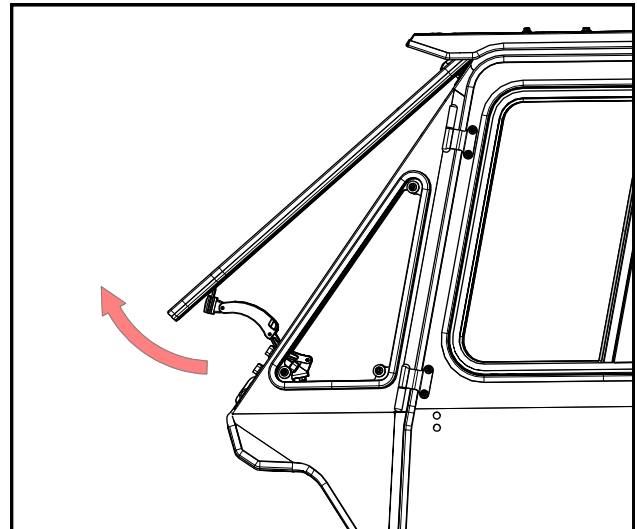

Fig. 20.2 A/C Cover Fasteners



Pop-Out Windshield

## CAB FEATURES & OPERATION

### POP-OUT WINDSHIELD

Your FXT series cab comes equipped with a pop-out windshield for ventilation. To open the windshield, simply lift up on both of the pop-out latches and rotate until the latches rest in the over-center position.

### REMOVABLE DOOR WINDOWS

For safety reasons, the doors on the FXT series cab are designed to remain on the vehicle at all times.

For added ventilation, the sliding windows are designed to be removed from all doors without tools.

To remove the window, loosen the (2) thumb screws at the tabs holding the bottom of the window and rotate the tabs away from the window rubber. Pull the bottom of the window away from the door and out of the tabs at the top of the window.

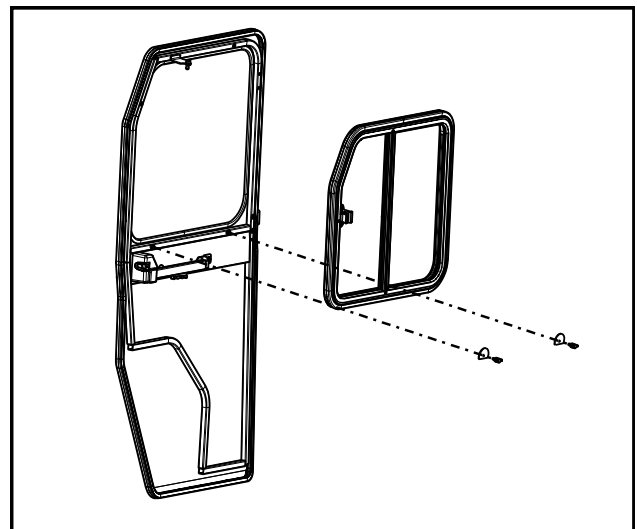

Removable Door Windows

## CAB FEATURES & OPERATION CONTINUED

### POP-UP CANOPY

This cab features a hinged and gas shock supported rear canopy. This feature allows for lifting of the cargo bed in either configuration of the rear seat when a cab is installed.

**CAUTION:** *The rear canopy must be unlatched and raised to lift the cargo bed in all configurations.*

To operate the canopy, rotate the handles at the rear underside of the canopy toward the rear of the cab until the latch tab is clear of the ROPS.

To lock the canopy in the down position, pull down on the plastic latch handles and rotate the handle toward the front, with the latch tab under the cab headers.

**CAUTION:** *This canopy is intended to be lowered and secured when the vehicle is in motion.*

### REAR SEAT CONVERSION

- This cab is designed to not impede conversion of the rear seat and cargo bed between 3-passenger mode and 6-passenger mode.
- The rear canopy must be unlatched and raised to convert the rear seat.
- The rear panel and cab sides are designed to seal in 6-passenger mode, and allow free movement of the rear seat into 3-passenger mode.
- An optional center panel is required to fully seal the front passenger compartment in 3-passenger mode.



Pop-Up Rear Canopy

## CARE AND MAINTENANCE

- Re-apply lubrication (preferably grease) periodically as needed to the door striker pins, door latch assemblies, and the door hinges.
- Check and tighten hardware after 40 hours of operation. Periodically inspect and tighten hardware for the remainder of the unit's life.
- Wash the painted surfaces of the cab with commercial automotive cleaning products.
- Clean door glass windows with glass cleaner. *Note: one of the windshield options, rear panel, and optional center panel windows on the cab are plastic. DO NOT clean plastic windows with harsh chemicals. It will damage the plastic. Mild soap and water should be used on all plastic windows.*
- Vinyl components should be washed with a mild solution of warm soapy water.
- Clear vinyl can be easily scratched. Be careful cleaning frost or snow from center curtain. Do not roll curtains in cold weather. The curtain becomes stiff and may crack. Keep curtain clean.

# KAWASAKI PRO-FXT CAB SERVICE PARTS P/N 1KAPFXTCA-AC & 1KAPFXTCAS1-AC

A/C FRONT CANOPY (ROOF) KIT  
P/N: 1ACKAPFXTDXTRF

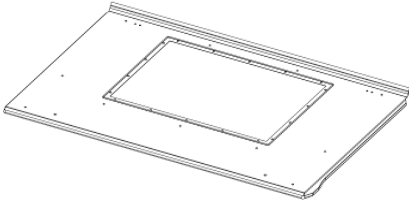

REAR CANOPY ASSEMBLY  
P/N: 8SV-101-00007

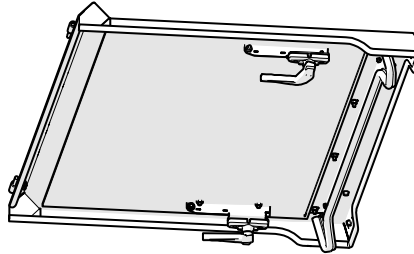

WINDSHIELD ASSEMBLY  
POLY. W/S: P/N: 8SV-102-00011  
GLASS W/S: P/N: 8SV-102-00020

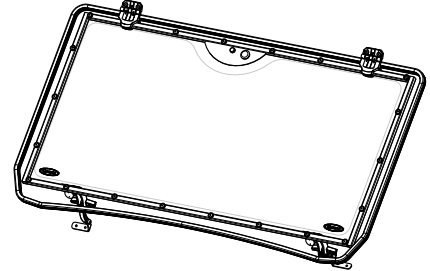

WINDSHIELD SUPPORT ASSEMBLY  
P/N: 8SV-103-00006

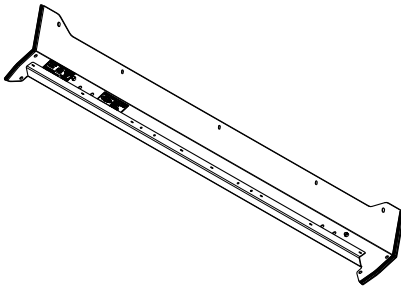

A-PILLAR ASSEMBLY, LEFT  
P/N: 8SV-104-00005-L

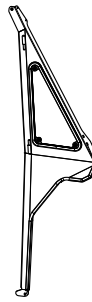

A-PILLAR ASSEMBLY, RIGHT  
P/N: 8SV-104-00005-R

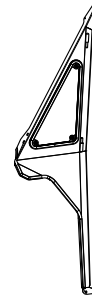

COWL ASSEMBLY  
POLY. W/S: P/N: 8SV-105-00008  
GLASS W/S: P/N: 8SV-105-00012

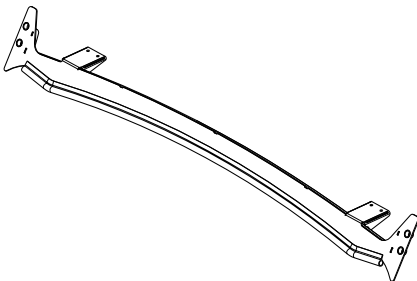

B-PILLAR ASSEMBLY, LEFT  
P/N: 8SV-113-00020-L

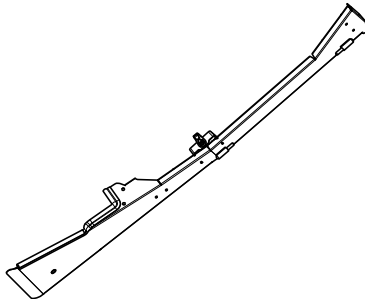

B-PILLAR ASSEMBLY, RIGHT  
P/N: 8SV-113-00020-R

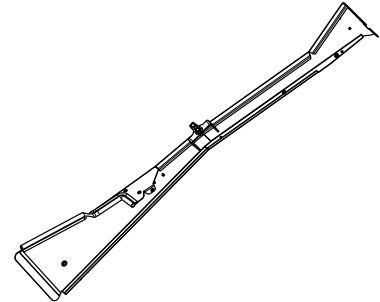

REAR PANEL ASSEMBLY, PFXT  
P/N: 8SV-106-00009

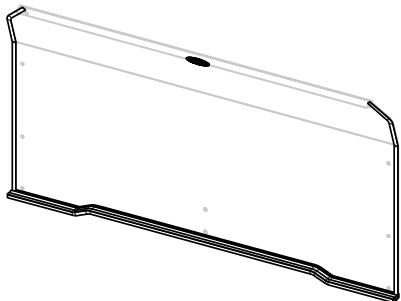

C-PILLAR ASSEMBLY, LEFT  
P/N: 8SV-108-00004-L

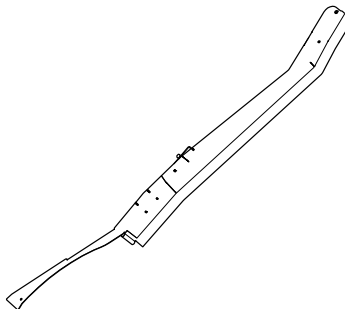

C-PILLAR ASSEMBLY, RIGHT  
P/N: 8SV-108-00004-R

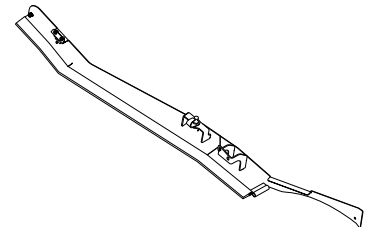



# KAWASAKI PRO-FXT CAB SERVICE PARTS

## P/N 1KAPFXTCA-AC & 1KAPFXTCAS1-AC

DOOR, LEFT (2 PER CAB)  
P/N: 8SV-107-00009-L  
(this p/n contains 1 door)

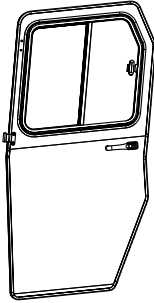

DOOR, REAR RIGHT  
P/N: 8SV-107-00009-R

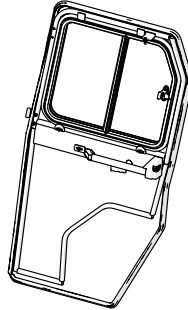

DOOR, FRONT RIGHT  
P/N: 8SV-107-00010-R

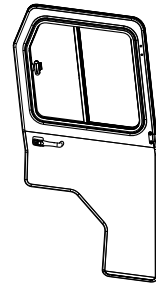

SIDE HEADER, LEFT  
P/N: 8SV-113-00021-L

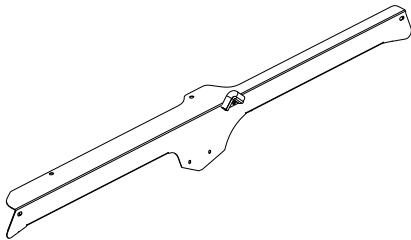

SIDE HEADER, RIGHT  
P/N: 8SV-113-00021-R

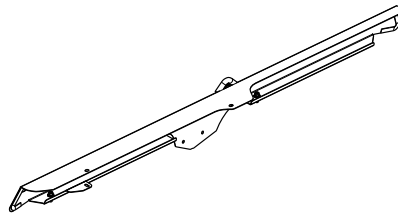

FUEL FILLER COVER PANEL  
P/N: 8SV-111-00002

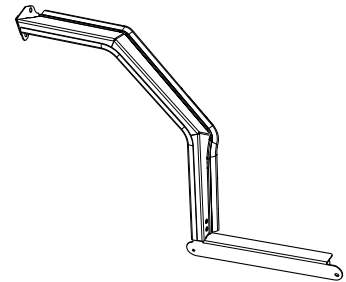

REAR PANEL SIDE, LEFT  
P/N: 8SV-111-00004-L

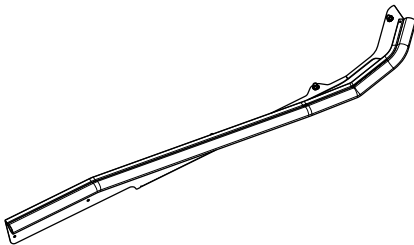

REAR PANEL SIDE, RIGHT  
P/N: 8SV-111-00004-R

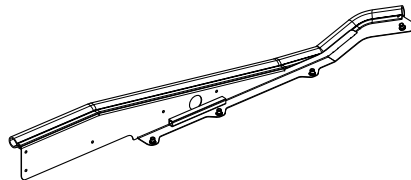

REAR PANEL BED SEAL  
P/N: 8SV-9SL-00008

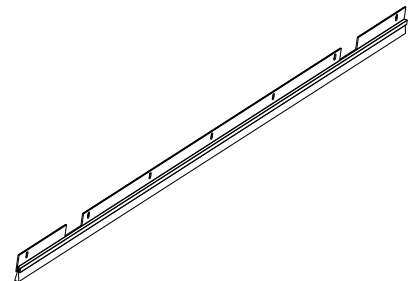

B-PILLAR BRACKET, LEFT  
P/N: 8SV-110-00024-L

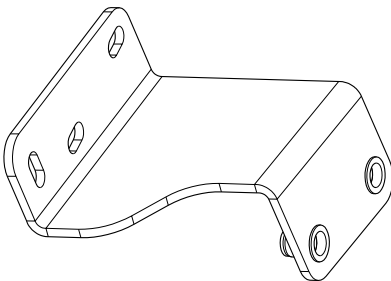

B-PILLAR BRACKET, RIGHT  
P/N: 8SV-110-00024-R

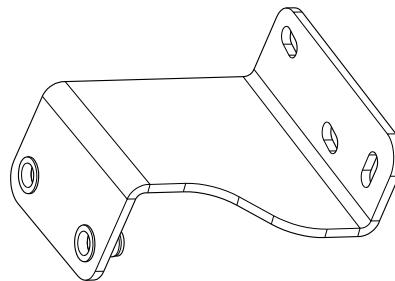

C-PILLAR BRACKET (2 PER CAB)  
P/N: 8SV-110-00020  
(this p/n contains 1 bracket)

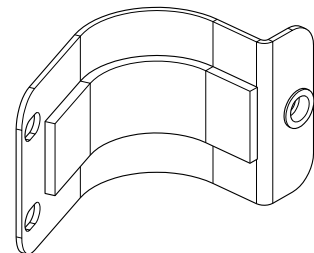

# KAWASAKI PRO-FXT CAB SERVICE PARTS

## P/N 1KAPFXTCA-AC & 1KAPFXTCAS1-AC

CANOPY GAS SPRING BRACKET, LEFT  
P/N: 8SV-110-00019-L

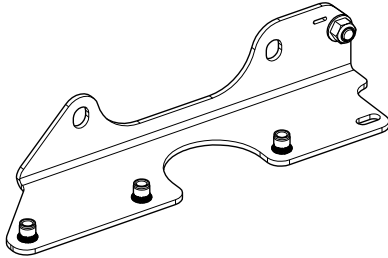

CANOPY GAS SPRING BRACKET, RIGHT  
P/N: 8SV-110-00019-R

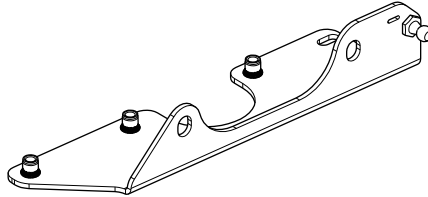

REAR PANEL CENTER BRACKET  
P/N: 8SV-110-00025

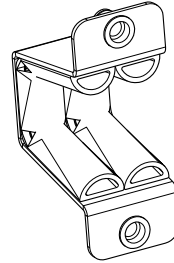

DOOR HINGE KIT  
P/N: 8SV-PL-00001

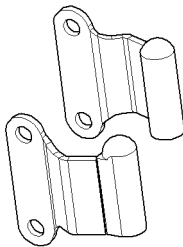

A-PILLAR WINDOW ASS'Y, RIGHT  
P/N: 8SV-9GL-00017-R

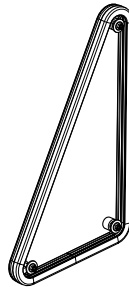

A-PILLAR WINDOW ASS'Y, LEFT  
P/N: 8SV-9GL-00017-L

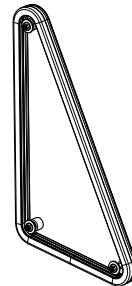



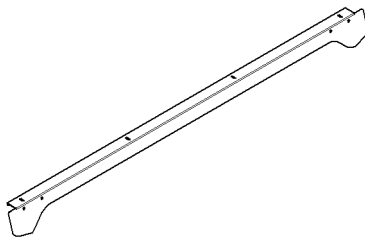



PANEL, UPPER REAR SEAL  
P/N: 8SV-SM-00249

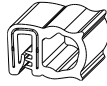

## ADDITIONAL SERVICE PARTS

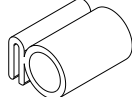
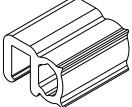
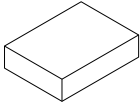
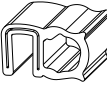
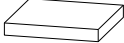
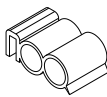
PART NUMBER	DESCRIPTION
8SV-P-00019	WINDSHIELD (POLYCARBONATE WINDOW ONLY) WITH MOUNTING HARDWARE
8SV-WL3	WINDSHIELD LATCH KIT (1 SET, L&R)
9SV-HWS	WINDSHIELD HINGE KIT - POLYCARBONATE WINDSHIELD
9SV-HWSAS1	WINDSHIELD HINGE KIT - GLASS WINDSHIELD
8SV-9GL-00017-L	LEFT A-PILLAR WINDOW, COMPLETE
8SV-9GL-00017-R	RIGHT A-PILLAR WINDOW, COMPLETE
8SV-SM-00223	BRACKET, A-PILLAR MOUNT
8SV-9SW-00007-L	SLIDING WINDOW, LEFT
8SV-9SW-00007-R	SLIDING WINDOW, RIGHT
9SW-LATCH	SLIDING WINDOW REPLACEMENT LATCH
9SV-OHRL	OUTSIDE HANDLE ROTARY LATCH KIT (SET OF 2)
9SV-DL03	INSIDE LATCH KIT WITH GRAB HANDLE (INCL. L & R)
9SV-DSTRH	DOOR STRIKER KIT-INCLUDES CASE HARDENED STRIKER BOLT (SET OF 5)
8SV-VKDRT-B4	DOOR SLIDING WINDOW HOLDING TAB (4)
9SV-VKTHTS	1/4-20 X 3/4" T-HANDLE THUMB SCREW (4)
9SV-GS02A	BALL STUDS, 10MM (BAG OF 10)
9SV-GS02Q	GAS SPRING - 12" W/QUICK RELEASE END (SET OF 2) (FOR GLASS WINDSHIELD ONLY)
9SV-GS06	GAS SPRING - 13-3/4", 500N (SET OF 2) (FOR CANOPY)
9SV-GS12Q	GAS SPRING - 20", 30LBS W/QUICK RELEASE END (SET OF 2) (FOR DOORS)
9SV-PHW010W	HINGE WASHER, WELD-ON, BRASS (BAG OF 4)
9SV-00058	ROOF HINGE KIT #1 (INCL. 1 SET OF L & R W/ LOW-PROFILE SLEEVE)
9SV-WL2	LATCH KIT (CANOPY) (SET OF L & R)
9SV-DP10	DOMES PLUG 3/8" (BAG OF 10)
9SV-DP11	DOMES PLUG 1/2" (BAG OF 10)
9SV-HWK-00024	HARDWARE KIT, PFXT

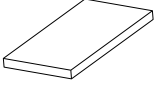
TRIM LOK, STD, 1/16" - 1/8" GRIP  9SV-PRO1-20	5/8" STD BULB, 1/16" GRIP  9SV-PRO2-15	ARCH P.S.A.  9SV-PRO9-10	3/4" SIDE BULB, 1/16" GRIP  9SV-PR17-20	1" ROUND BULB, 1/16" GRIP  9SV-PR19-10	1/2" WEATHERSEAL  9SV-PR20-10
5/8" SIDE BULB 1/16" GRIP  9SV-PR27-5	7/16" SIDE BULB 1/4" GRIP  9SV-PR29-15	EXPANDING FOAM 1/4" x 3/4"  9SV-PR30-5	3/4" SIDE BULB, 1/4" GRIP  9SV-PR38-15	FOAM TAPE, 1/8" X 1"  9SV-PR39-5	1-1/2" SIDE BULB, 1/16" GRIP  9SV-PR41-5
RUBBER FOAM, 1/2" X 9/16"  9SV-PR43-4	2.1" FLAT, 1/16" GRIP  9SV-PR54-5	FOAM TAPE 1/2" X 1/16"  9SV-DT-15			



# OPTIONAL ACCESSORIES

FRONT LED WORK LIGHTS  
(P/N: 1KAPFXFWL)

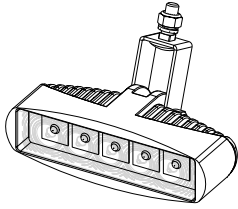

REAR LED WORK LIGHTS  
(P/N: 1KAPFXRWL)

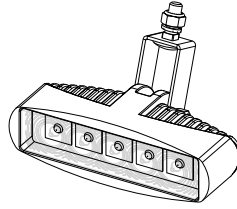

LED CORNER FLASHER LIGHTS  
(P/N: 1KAPFXCFL)

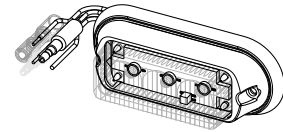

HEATER (P/N: 9PH20S61)

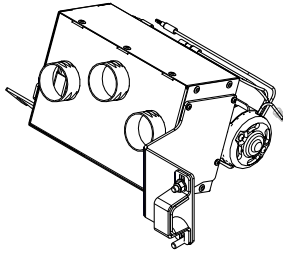

SIDE VIEW MIRRORS (P/N: 9PM5)

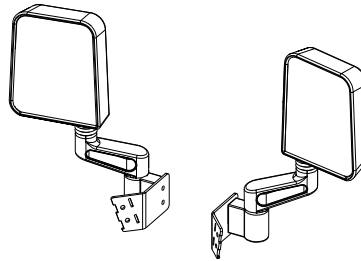

REAR VIEW MIRROR (P/N: 9PM3)

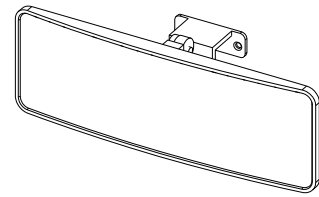

DOME LIGHT (P/N: 9LEDD14)

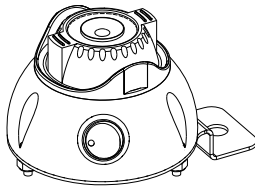

FRONT WIPER KIT, 172 DEGREE SWEEP, 12V W/ 16" FLEX BLADE (P/N: 1KAPFXWK)

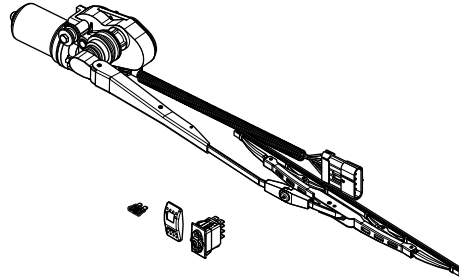



# BOLT TORQUE

## BOLT TORQUE SPECIFICATIONS

### GENERAL TORQUE SPECIFICATION TABLE

Use the following torques when special torques are not given. These values apply to fasteners as received from suppliers, dry, or when lubricated with normal engine oil. They do not apply if special graphited or moly disulphide greases or other extreme pressure lubricants are used. This applies to both UNF and UNC threads. Remember to always use grade five or better when replacing bolts.

**IMPORTANT: On all PLATED GRADE 8 bolts, reduce torque 15% from listed bolt torque specification.**

SAE Grade No.		2				5				8*			
Bolt head identification mark as per grade. NOTE: Manufacturing Marks Will Vary													
		TORQUE		TORQUE		TORQUE		TORQUE		TORQUE		TORQUE	
Bolt Size		Pounds Feet		Newton-Meters		Pounds Feet		Newton-Meters		Pounds Feet		Newton-Meters	
Inches	Millimeters	Min.	Max.	Min.	Max.	Min.	Max.	Min.	Max.	Min.	Max.	Min.	Max.
1/4	6.35	5	6	7	8	9	11	12	15	12	15	16	20
5/16	7.94	10	12	14	16	17	20.5	23	28	24	29	33	39
3/8	9.53	20	23	27	31	35	42	48	57	45	54	61	73
7/16	11.11	30	35	41	47	54	64	73	87	70	84	95	114
1/2	12.70	45	52	61	70	80	96	109	130	110	132	149	179
9/16	14.29	65	75	88	102	110	132	149	179	160	192	217	260
5/8	15.88	95	105	129	142	150	180	203	244	220	264	298	358
3/4	19.05	150	185	203	251	270	324	366	439	380	456	515	618
7/8	22.23	160	200	217	271	400	480	542	651	600	720	814	976
1	25.40	250	300	339	406	580	696	787	944	900	1080	1220	1464
1-1/8	25.58	-	-	-	-	800	880	1085	1193	1280	1440	1736	1953
1-1/4	31.75	-	-	-	-	1120	1240	1519	1681	1820	2000	2468	2712
1-3/8	34.93	-	-	-	-	1460	1680	1980	2278	2380	2720	3227	3688
1-1/2	38.10	-	-	-	-	1940	2200	2631	2983	3160	3560	4285	4827

\*Thick Nuts must be used with Grade 8 bolts

### METRIC BOLT TORQUE SPECIFICATIONS



Size of Screw	Property Class	Course Thread			Fine Thread		
		Pitch (mm)	Pounds Feet	Newton-Meters	Pitch (mm)	Pounds Feet	Newton-Meters
M6	5.6	1.0	3.6-5.8	4.9-7.9	-	-	-
	8.8		5.8-9.4	7.9-12.7		-	-
	10.9		7.2-10	9.8-13.6		-	-
M8	5.6	1.25	7.2-14	9.8-19	1.0	12-17	16.3-23
	8.8		17-22	23-29.8		19-27	25.7-36.6
	10.9		20-26	27.1-35.2		22-31	29.8-42
M10	5.6	1.5	20-25	27.1-33.9	1.25	20-29	27.1-39.3
	8.8		34-40	46.1-54.2		35-47	47.4-63.7
	10.9		38-46	51.5-62.3		40-52	54.2-70.5
M12	5.6	1.75	28-34	37.9-46.1	1.25	31-41	42-55.6
	8.8		51-59	69.1-79.9		55-68	75.9-92.1
	10.9		57-66	77.2-89.4		62-75	84-101.6
M14	5.6	2.0	49-56	66.4-75.9	1.5	52-64	70.5-86.7
	8.8		81-93	109.8-126		90-106	122-143.6
	10.9		96-109	130.1-147.7		107-124	145-168
M16	5.6	2.0	67-77	90.8-104.3	1.5	69-83	93.6-112.5
	8.8		116-130	157.2-176.2		120-138	162.6-187
	10.9		129-145	174.8-196.5		140-158	189.7-214.1
M18	5.6	2.0	88-100	119.2-136	1.5	100-117	136-158.5
	8.8		150-168	203.3-227.6		177-199	239.8-269.6
	10.9		175-194	237.1-262.9		202-231	273.7-313
M20	5.6	2.5	108-130	146.3-176.2	1.5	132-150	178.9-203.3
	8.8		186-205	252-277.8		206-242	279.1-327.9
	10.9		213-249	288.6-337.4		246-289	333.3-391.6